

## TABLE OF CONTENTS

SAFETY, MAINTENANCE AND ADJUSTMENTS .....	Section 1
TROUBLESHOOTING .....	Section 2
ENGINE DISASSEMBLY .....	Section 3
FUEL SYSTEMS AND CARBURETION .....	Section 4
GOVERNOR .....	Section 5
CYLINDER HEADS AND VALVES .....	Section 6
STARTERS .....	Section 7
LUBRICATION SYSTEMS .....	Section 8
CYLINDERS AND CRANKCASE COVERS/SUMPS .....	Section 9
CRANKSHAFTS AND CAMSHAFTS .....	Section 10
PISTONS, RINGS AND CONNECTING RODS .....	Section 11
ENGINE ASSEMBLY .....	Section 12
ENGINE SPECIFICATIONS .....	Section 13

1

2

3

4

5

6

7

8

9

10

11

12

13

# Section 1



## Safety, Maintenance and Adjustments

---

	Page
<b>AIR CLEANER SERVICE</b> .....	9
Round Air Cleaner .....	9
Square Air Cleaner .....	10
Cyclonic Air Cleaner .....	10
<b>ARMATURE AIR GAP ADJUSTMENT</b> .....	11
<b>BRIGGS &amp; STRATTON NUMERICAL IDENTIFICATION SYSTEM</b> .....	6
<b>CARBURETOR ADJUSTMENTS</b> .....	11
Models 290000 – 350000 .....	11
Performance Control™ Engines .....	13
Models 351400, 380400, 351700, 380700 .....	14
<b>CHOKE CONTROL ADJUSTMENT</b> .....	16
<b>COMBUSTION CHAMBER DEPOSITS</b> .....	16
<b>COOLING SYSTEM CLEANING</b> .....	16
<b>CRANKCASE OIL</b> .....	17
<b>FUEL AND OIL RECOMMENDATIONS</b> .....	7
Fuel Recommendations .....	7
Oil Recommendations .....	8
<b>GOVERNOR ADJUSTMENTS</b> .....	18
Static Governor Adjustment .....	18
Dynamic Governor Adjustment .....	18
<b>IN THE INTEREST OF SAFETY</b> .....	2
<b>MAINTENANCE AND ADJUSTMENTS SCHEDULE</b> .....	8
<b>OIL COOLER</b> .....	22
<b>OVERHAUL PROCEDURE</b> .....	24
Disassemble .....	24
Inspection and Repairs .....	25
Reassemble .....	25
<b>SPARK PLUGS</b> .....	22
<b>SPEED CONTROL WIRE ADJUSTMENT</b> .....	23
<b>TUNE UP PROCEDURE</b> .....	24
<b>VALVE CLEARANCE ADJUSTMENT</b> .....	23

## IN THE INTEREST OF SAFETY

1

	 <b>DANGER</b>
<b>FOLLOW INSTRUCTIONS CAREFULLY !</b>	
<ul style="list-style-type: none"><li>• Before attempting to service this equipment, read and understand this manual and the operating instructions.</li><li>• Failure to follow instructions could result in <b>DEATH, SERIOUS INJURY</b> (including paralysis) or property damage.</li></ul>	

\* Briggs & Stratton does not necessarily know what equipment this engine will power. For that reason, carefully read and understand the operating instructions for the equipment your engine is powering.


### THE OPERATING, MAINTENANCE & REPAIR INSTRUCTIONS CONTAIN SAFETY INFORMATION TO:


- Make you aware of hazards associated with engines
- Inform you of the risk of injury associated with those hazards, and
- Tell you how to avoid or reduce the risk of injury.


### SAFETY ALERT SYMBOL

The safety alert symbol () is used to identify safety information about hazards that can result in personal injury.

A signal word (DANGER, WARNING, or CAUTION) is used with the alert symbol to indicate the likelihood and the potential severity of injury. In addition, a hazard symbol may be used to represent the type of hazard.

 **DANGER** indicates a hazard that, if not avoided, **will result in death or serious injury.**

 **WARNING** indicates a hazard that, if not avoided, **could result in death or serious injury.**

 **CAUTION** indicates a hazard that, if not avoided, **might result in minor or moderate injury.**









**CAUTION**, when used **without** the alert symbol, indicates a situation that **could result in damage to the engine.**




**NOTE:** A **NOTE** is used to inform you of a method, reference or procedure that could assist with specific operations or procedures.




### HAZARD SYMBOLS AND MEANINGS





 Fire	 Explosion	 Hot Surface
 Shock	 Toxic Fumes	 Moving Parts
 Eye Protection Required	 Flying Objects	 Kickback

### INTERNATIONAL SYMBOLS AND MEANINGS





 Safety Alert	 Oil	 Read Operator's Manual
 Choke	 Start Position	 Stop
 Fuel	 Fuel Shutoff	



 	<p style="text-align: center;"> <b>WARNING</b></p> <p>Gasoline and its vapors are extremely flammable and explosive.</p> <p>Fire or explosion can cause severe burns or death.</p> <p><b>WHEN ADDING FUEL</b></p> <ul style="list-style-type: none"> <li>• Turn engine OFF and let engine cool at least 2 minutes before removing gas cap.</li> <li>• Fill fuel tank outdoors or in a well-ventilated area. Keep gasoline and its vapors away from sparks, open flames, pilot lights, heat, and other ignition sources.</li> <li>• Do not overfill fuel tank. Fill tank to approximately 1-1/2 inches below top of neck to allow for fuel expansion.</li> <li>• Check fuel lines, tank, cap, and fittings frequently for cracks or leaks. Replace if necessary.</li> </ul> <p><b>WHEN STARTING ENGINE</b></p> <ul style="list-style-type: none"> <li>• Make sure spark plug, muffler, fuel cap and air cleaner are in place.</li> <li>• Do not crank engine with spark plug removed.</li> <li>• If fuel spills, wait until it evaporates and the vapors dissipate before starting engine.</li> <li>• If engine floods, set choke to OPEN/RUN position, place throttle in FAST position. Crank until engine starts.</li> </ul> <p><b>WHEN OPERATING EQUIPMENT</b></p> <ul style="list-style-type: none"> <li>• Do not tip engine or equipment at an angle that causes gasoline to spill.</li> <li>• Do not choke carburetor to stop engine.</li> </ul> <p><b>WHEN TRANSPORTING EQUIPMENT</b></p> <ul style="list-style-type: none"> <li>• Transport with fuel tank EMPTY or with fuel shut-off valve OFF.</li> </ul> <p><b>WHEN STORING GASOLINE OR EQUIPMENT WITH FUEL IN TANK</b></p> <ul style="list-style-type: none"> <li>• Store away from furnaces, stoves, water heaters or other appliances that have pilot light or other ignition source. These can ignite gasoline vapors.</li> </ul>
--	---



 	<p style="text-align: center;"> <b>WARNING</b></p> <p>Kerosene and its vapors are extremely flammable, and should be handled with the same precautions as gasoline.</p>
--	--

  	<p style="text-align: center;"> <b>WARNING</b></p> <p>Unintentional sparking can result in fire or electric shock.</p> <p>Unintentional start-up can result in entanglement, traumatic amputation, or laceration.</p>
---	--



<p><b>BEFORE PERFORMING ADJUSTMENTS OR REPAIRS</b></p> <ul style="list-style-type: none"> <li>• Disconnect spark plug wire and keep it away from spark plug.</li> <li>• Disconnect battery at negative terminal (only engines with electric start).</li> </ul> <p><b>WHEN TESTING FOR SPARK</b></p> <ul style="list-style-type: none"> <li>• Use approved spark plug tester.</li> <li>• DO NOT check for spark with spark plug removed.</li> </ul>	
--	--



  	<p style="text-align: center;"> <b>WARNING</b></p> <p>All fuel components should be in good condition and properly maintained.</p> <ul style="list-style-type: none"> <li>• Repairs should only be made with factory approved parts.</li> <li>• Repair work should be done by a qualified technician.</li> <li>• Flexible supply lines should be checked regularly to make sure they are in good condition. Replace damaged or leaking components.</li> </ul>
---	--

	 <b>WARNING</b>
	<p>Engines give off carbon monoxide, an odorless, colorless, poison gas.</p> <p>Breathing carbon monoxide can cause nausea, fainting or death.</p>
<ul style="list-style-type: none"> <li>• Start and run engine outdoors.</li> <li>• DO NOT start or run engine in enclosed area, even if doors or windows are open.</li> <li>• Inhalation of high concentrations of vapor, even for short periods can cause unconsciousness or might prove fatal.</li> <li>• Inhalation may cause irritation to the nose and throat, headache, nausea vomiting, dizziness, and drowsiness.</li> <li>• Unconsciousness or asphyxiation may result in poorly ventilated areas or confined spaces.</li> </ul>	

	 <b>WARNING</b>
	<p>Running engines produce heat. Engine parts, especially muffler, become extremely hot.</p> <p>Severe thermal burns can occur on contact.</p> <p>Combustible debris, such as leaves, grass, brush, etc. can catch fire.</p>
<ul style="list-style-type: none"> <li>• Allow muffler, engine cylinder and fins to cool before touching.</li> <li>• Remove accumulated combustibles from muffler area and cylinder area.</li> <li>• Install and maintain in working order a spark arrester before using equipment on forest-covered, grass-covered, brush-covered unimproved land. The state of California requires this (Section 4442 of the California Public Resources Code). Other states may have similar laws. Federal laws apply on federal land.</li> </ul>	

	 <b>WARNING</b>
	<p>Rotating parts can contact or entangle hands, feet, hair, clothing, or accessories.</p> <p>Traumatic amputation or severe laceration can result.</p>
<ul style="list-style-type: none"> <li>• Operate equipment with guards in place.</li> <li>• Keep hands and feet away from rotating parts.</li> <li>• Tie up long hair and remove jewelry.</li> <li>• DO NOT wear loose-fitting clothing, dangling drawstrings or items that could become caught.</li> </ul>	

	 <b>WARNING</b>
	<p>Rapid retraction of starter cord (kickback) will pull hand and arm toward engine faster than you can let go.</p> <p>Broken bones, fractures, bruises or sprains could result.</p>
<ul style="list-style-type: none"> <li>• When starting engine, pull cord slowly until resistance is felt, then pull rapidly.</li> <li>• Remove all external equipment/engine loads before starting engine.</li> <li>• Direct coupled equipment components such as, but not limited to, blades, impellers, pulleys, sprockets, etc., must be securely attached.</li> </ul>	

	<b>WARNING</b>	
<p>The engine exhaust from this product contains chemicals known to the State of California to cause cancer, birth defects, or other reproductive harm.</p>		

## Additional Precautions

Before working on the engine, read and understand the applicable sections of this manual. Follow all safety warnings. Death, personal injury and/or property damage may occur unless service instructions are followed carefully.

**DO NOT** store, spill, or use gasoline near an open flame, or near an appliance like a stove, furnace, or water heater that uses a pilot light or creates a spark.

**DO NOT** refuel indoors or in an unventilated area.

**DO NOT** operate or tip engine/equipment at an angle that causes gasoline spillage.

**DO NOT** operate engine if gasoline is spilled, when smell of gasoline is present, or when other explosive conditions exist. (Move equipment away from spill. Avoid ignition until gasoline has evaporated.)

**DO NOT** transport engine with fuel in tank or fuel shut-off valve open.

**DO NOT** choke carburetor to stop engine, especially in an enclosed vehicle. (Gradually reduce engine speed before stopping.)

**DO NOT** tamper with governor springs, links or other parts to increase engine speed. (Run engine at speed set for equipment manufacturer.)

**DO NOT** check for spark with spark plug removed. (Use an approved tester.)

**DO NOT** run engine with blower housing or other safety shields removed.

**DO NOT** crank engine with spark plug removed. (If engine is flooded, place throttle in FAST position and crank until engine starts.)

**DO NOT** strike flywheel with a hammer or hard object. This could cause the flywheel to shatter in operation.

(Use only Briggs & Stratton approved tools and procedures to remove the flywheel.)

**DO NOT** operate engine without a muffler. (Inspect periodically and replace if worn or leaking. If engine is equipped with muffler deflector, inspect periodically and replace if necessary. Replacement parts must be same as on original equipment.)

**DO NOT** operate engine with grass, leaves or other combustible material accumulated in the muffler area.

**DO NOT** touch hot muffler, cylinder, or fins which can cause burns.

**DO NOT** start engine with air cleaner or air cleaner cover removed.

**DO NOT** attempt to start engine with cutting blade loose or removed. (Blade must be tight, otherwise kickback may occur.)

**DO NOT** remove fuel tank cap or fill the fuel tank while the engine is hot or running. **DO NOT** refuel indoors or in an unventilated area. Allow the engine to cool at least 2 minutes before refueling.

**WEAR** suitable eye protection (safety glasses, goggles or face shield) when performing repair procedures.

**PREVENT ACCIDENTAL STARTING** by disconnecting spark plug wire from spark plug when servicing engine or equipment. Disconnect negative wire from battery terminal if equipped with electric starting system.

**USE ONLY** genuine Briggs & Stratton parts or their equivalent. The use of non-equivalent replacement parts may damage the engine.

**GASEOUS FUEL ENGINES** – Check fuel lines and fittings frequently for cracks or leaks. Replace as necessary.

# BRIGGS & STRATTON NUMERICAL IDENTIFICATION SYSTEM

## YOUR KEY TO THE WORLD'S FINEST ENGINES

This chart explains the unique Briggs & Stratton numerical model designation system. It is possible to determine most of the important mechanical features of the engine by merely knowing the model number. Here is how it works:

- A. The first one or two digits indicate the approximate CUBIC INCH DISPLACEMENT.
- B. The first digit after the displacement indicates the BASIC DESIGN SERIES, relating to cylinder construction, ignition, general configuration, etc.
- C. The second digit after the displacement indicates ORIENTATION OF CRANKSHAFT.
- D. The third digit after the displacement indicates TYPE OF BEARINGS, and whether or not the engine is equipped with REDUCTION GEAR or AUXILIARY DRIVE.
- E. The last digit indicates the TYPE OF STARTER.

### BRIGGS & STRATTON MODEL NUMBERING SYSTEM

<u>A</u>	<u>FIRST DIGIT AFTER DISPLACEMENT</u> <u>B</u>	<u>SECOND DIGIT AFTER DISPLACEMENT</u> <u>C</u>	<u>THIRD DIGIT AFTER DISPLACEMENT</u> <u>D</u>	<u>FOURTH DIGIT AFTER DISPLACEMENT</u> <u>E</u>
<u>CUBIC INCH DISPLACEMENT</u>	<u>BASIC DESIGN SERIES</u>	<u>CRANKSHAFT ORIENTATION</u>	<u>PTO BEARING, REDUCTION GEAR, AUXILIARY DRIVE, LUBRICATION</u>	<u>TYPE OF STARTER</u>
6	0	0 to 4 - Horizontal Shaft	0 - Plain Bearing/DU Non-Flange Mount	0 - Without Starter
8	1	5 to 9 - Vertical Shaft		1 - Rope Starter
9	2	A to G - Horizontal Shaft	1 - Plain Bearing Flange Mounting	2 - Rewind Starter
10	3	H to Z - Vertical Shaft	2 - Sleeve Bearing Flange Mounting Splash Lube	3 - Electric Starter Only 110 or 230 Volt Gear Drive
11	4		3 - Ball Bearing Flange Mounting Splash Lube	4 - Electric Starter/110 or 230 Volt Gear Drive with Alternator
12	5		4 - Ball Bearing Flange Mounting Pressure Lubrication	5 - Electric Starter Only 12 or 24 Volt Gear Drive
13	6		5 - Plain Bearing Gear Reduction (6 to 1) CCW Rotation Flange Mounting	6 - Alternator Only
16	7		6 - Ball Bearing Gear Reduction (2 to 1) CCW Rotation	7 - Electric Starter 12 or 24 Volt Gear Drive with Alternator
18	8		7 - Plain Bearing Pressure Lubrication	8 - Vertical Pull Starter or Side Pull Starter
19	9		8 - Plain Bearing Auxiliary Drive (PTO) Perpendicular to Crankshaft	9 - Mechanical Starter
20	A to Z		9 - Plain Bearing Auxiliary Drive Parallel to Crankshaft	A - Electric Starter 12 or 24 Volt Gear Drive with Alternator and Inverter
21			A - Plain Bearing Pressure Lubrication Without Oil Filter	
22				
23				
24				
25				
28				
29				
30				
31				
32				
35				
38				
40				
42				
43				
44				
46				
47				
52				
54				
58				

EXAMPLE - To identify Model 303447:

<u>30</u>	<u>3</u>	<u>4</u>	<u>4</u>	<u>7</u>
30 Cubic Inch	Design Series 3	Horizontal Shaft	Ball Bearing Flange Mounting Pressure Lubrication	Electric Starter 12 or 24 Volt Gear Drive with Alternator

**TYPE 1234-01**, The type number identifies the engines mechanical parts, color of paint, decals, governed speed, and Original Equipment Manufacturer.

**CODE 01061201**, The code is the manufacturing date and is read as follows:

<u>YEAR</u>	<u>MONTH</u>	<u>DAY</u>	<u>ASSEMBLY LINE AND MANUFACTURING PLANT</u>
01	06	12	01

Revised 4/04

## FUEL & OIL RECOMMENDATIONS

### Fuel Recommendations

#### Gasoline Engines



- Use clean, fresh regular unleaded gasoline with a minimum of **85 octane**. Fresh fuel prevents gum from forming in the fuel system or on essential carburetor parts. Purchase fuel in a quantity that can be used within 30 days.
- Do not use gasoline containing Methanol.
- Do not mix oil with gasoline.
- For engine protection use Briggs & Stratton Fuel Stabilizer **#5041** or single use pouch **#5058** available from your Authorized Briggs & Stratton Dealer.

**CAUTION:** Some fuel, called “oxygenated” or “reformulated” gasoline, is gasoline blended with alcohol or ether. Excessive amounts of these blends can damage the fuel system or cause performance problems. If any undesirable operating symptoms occur, use gasoline with a lower percentage of alcohol or ether.

#### Inline Fuel Filter Service

Replace inline fuel filter yearly or every **100 hours**, whichever occurs first. Replace filter if dirt or water are present. See illustrated parts list for correct fuel filter.



#### Gaseous Fuel Engines

	 <b>DANGER</b>
	<b>AVOID INJURY!</b> Gaseous fuel systems should only be worked on in a very well ventilated area.
<ul style="list-style-type: none"><li>• Many state, county and city governments require that service be performed <b>ONLY</b> outdoors.</li><li>• Have a fan blowing across the engine <b>BEFORE</b> loosening fuel line connections!</li></ul>	

**NOTE:** Gaseous fueled engines require special equipment to remain emissions certified. See a certified gaseous fuel dealer or a certified OEM dealer for service.

Use clean fuel free of moisture or particulate material, within the following values:

For propane (LPG) fueled engines, use commercial grade HD% propane. Recommended fuel has a minimum fuel energy of **2500 BTU/ft<sup>3</sup>**, maximum propylene content **5%**, butane, heavier gas content **2.5%**, minimum propane content **90%**.

	 <b>WARNING</b>
	<b>AVOID INJURY!</b> Gaseous fueled equipment is equipped with an automatic safety gas fuel lock-off valve.
<ul style="list-style-type: none"><li>• Do not operate gaseous fueled equipment if the fuel lock-off valve is missing or inoperative.</li></ul>	

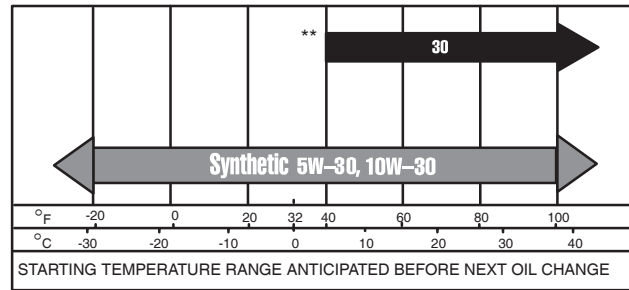


## Oil Recommendations

Oil has four purposes. It cools, cleans, seals and lubricates. During normal operation, small particles of metal from the cylinder walls, pistons, bearings and combustion deposits contaminate the oil. Dust particles from the air also contaminate the oil, forming an abrasive mixture that can wear internal engine parts if the oil is not changed regularly. Fresh oil assists in cooling. Old oil gradually thickens and loses its cooling ability and its lubricating qualities.

Briggs & Stratton OHV V-Twin engines are lubricated with a gear-driven oil pump.

Use a high quality detergent oil classified "For Service **SJ or HIGHER**" such as Briggs & Stratton 30 weight oil part #100005 or #100028. Detergent oils keep the engine cleaner and retard the formation of gum and varnish deposits. Do not use additives with recommended oils.



Air cooled engines run hotter than automotive engines. Use of multi-viscosity oils (10W-30, etc.) in ambient temperatures above **40° F (4° C)** will result in high oil consumption. If multi-viscosity oil is used, check oil level more frequently to prevent any possible engine damage due to lack of lubrication.

\*\* SAE 30 oil, if used in ambient temperatures below **40° F (4° C)** will result in hard starting and possible engine damage due to inadequate lubrication.

Synthetic oil meeting ILSAC GF-2, API certification mark and API service symbol with "SJ/CF ENERGY CONSERVING" rating or higher, is an acceptable oil at all temperatures.

**NOTE: Use of synthetic oil does not alter the required oil change intervals.**

## MAINTENANCE & ADJUSTMENTS SCHEDULE

The following maintenance schedule is a general guide. See the Engine Operating & Maintenance Instructions for details on specific engine models.



Maintenance Schedule	8 Hours or Daily	25 Hours or Every Season	50 Hours or Every Season	100 Hours or Every Season	500 Hours
Check oil level *	•				
Change oil			• Note #1		
Change oil filter				•	
Clean/Replace air filter pre-cleaner		• Note #2			
Clean/Replace air filter cartridge				• Note #2	
Clean cooling system				• Note #2	
Inspect/clean spark arrester (if used)			•		
Replace or clean spark plugs				•	
Replace in-line fuel filter				•	
Remove combustion chamber deposits					•

\* Change oil after the first **5 to 8 hours** of operation (break-in period), then after every **50 hours** or every season.

**NOTE: #1** – Change oil every 25 hours when operating under heavy load or in high temperatures.

**NOTE: #2** – Clean more often under dusty conditions or when airborne debris is present. Replace air cleaner parts when dirty.

## AIR CLEANER SERVICE

	 <b>WARNING</b>
<b>AVOID FIRES!</b>	
<ul style="list-style-type: none"><li>• Never operate an engine with the air cleaner assembly or air cleaner cartridge removed!</li></ul>	

A properly serviced air cleaner protects internal engine parts from airborne dirt and dust particles. If air cleaner instructions are not followed, particles that should be collected in the air cleaner will pass into the engine. These particles are abrasive and will cause the piston rings and cylinder bore to wear quickly. As the rings and bore wear, the abrasive particles enter the crankcase and contaminate the oil, forming an abrasive mixture that will wear internal parts.

Examine the air cleaner on every engine brought in for a check up or repair. If the air cleaner shows signs of neglect, show it to the customer before cleaning. Instruct the customer on proper care to assure long engine life.

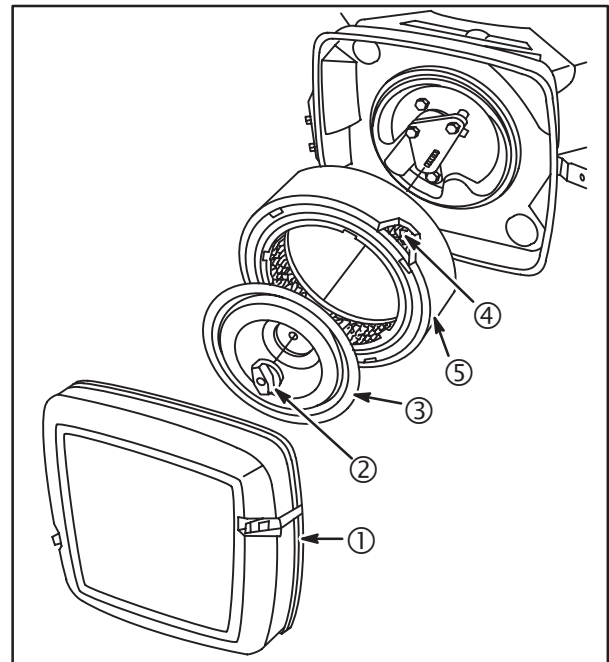
**NOTE:** Replace worn or damaged air cleaner gaskets and mounting gaskets to prevent dirt and dust from entering engine through improper sealing. Replace air cleaner mounting bracket if bent.

Remove and service foam pre-cleaner, if equipped, every **25** hours or every season, whichever occurs first. Service cartridge every **100** hours or every season, whichever occurs first.

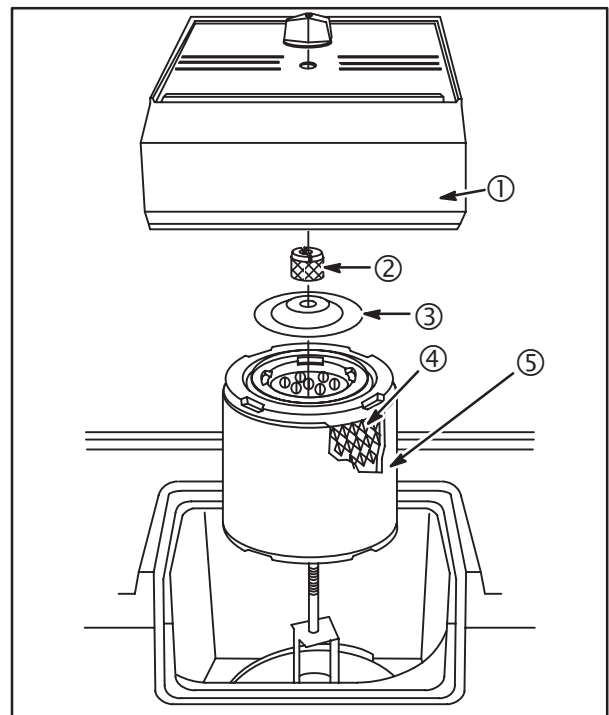
**NOTE:** Service air cleaner more often under dusty conditions.

### Round Air Cleaner

1. Remove cover (1), knob (2), plate (3), and air cleaner cartridge (4) with pre-cleaner (5), **Fig. 1** or **Fig. 2**.



**Fig. 1**



**Fig. 2**

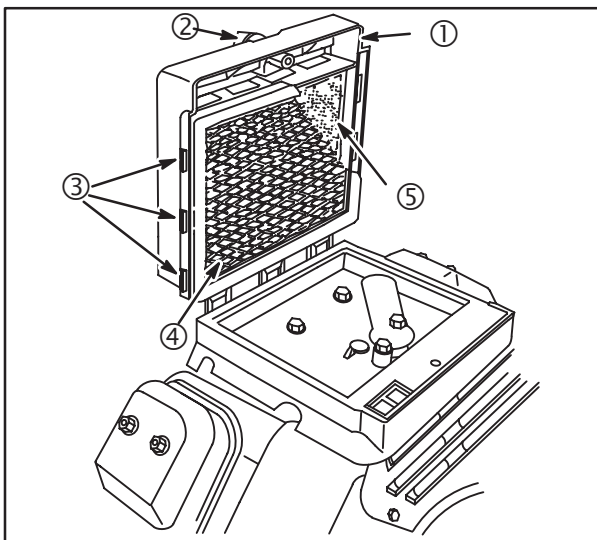
2. Remove foam pre-cleaner from cartridge.
3. Wash pre-cleaner in liquid detergent and water.
4. Squeeze dry in a clean cloth. Set aside.
5. Inspect cartridge. Replace if damaged or dirty.

**CAUTION:** DO NOT use petroleum solvents to clean paper cartridge.  
DO NOT oil paper cartridge.  
DO NOT use pressurized air to clean or dry paper cartridge.

6. Reinstall pre-cleaner over cartridge.
7. Install cartridge to air cleaner.
8. Install plate, knob and air cleaner cover.

### Square Air Cleaner

1. Remove knob(s) (2) and cover assembly (1), **Fig. 3.**



**Fig. 3**

2. Remove cartridge (4) and pre-cleaner (5) from cover.
3. Wash pre-cleaner in liquid detergent and water.
4. Squeeze dry in a clean cloth. Set aside.
5. Inspect cartridge. Replace if damaged or dirty.

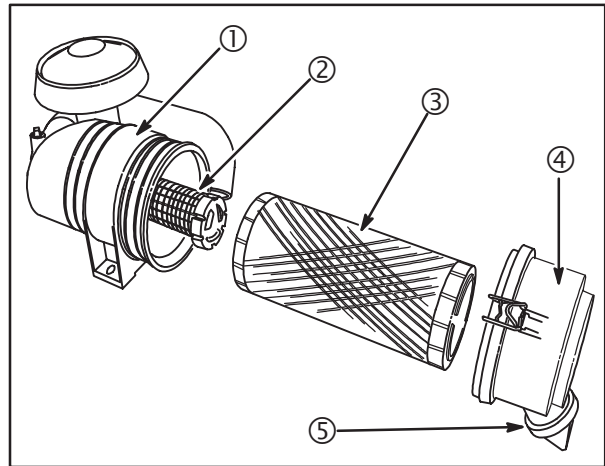
**CAUTION:** DO NOT use petroleum solvents to clean paper cartridge.  
DO NOT oil paper cartridge.  
DO NOT use pressurized air to clean or dry paper cartridge.

6. Install pre-cleaner in cover with foam toward cover. (Nylon screen toward paper element.)
7. Install paper cartridge in cover with tabs on cartridge (3) in slots of cover, **Fig. 3.**
8. Reinstall cover assembly on air cleaner body.

### Cyclonic Air Cleaner

**NOTE:** The debris valve automatically discharges dust and debris. There should be minimal debris for removal.

1. Remove debris from the air cleaner by squeezing the ends of the debris valve (5), **Fig. 4.**



**Fig. 4**

2. Remove the cover (4) from the air cleaner housing (1).
3. Remove the primary filter (3) and inspect. Replace the filter if damaged, or dirty.

**CAUTION:** DO NOT clean or oil these filters.  
DO NOT use pressurized air to clean or dry filters.  
REPLACE filters if damaged or dirty

4. Inspect the safety filter (2).

**NOTE:** DO NOT remove the safety filter (2) as part of the inspection.  
If it is necessary to remove the safety filter, **Fig. 5,** be sure all debris is removed from the air cleaner housing before removal.  
Replace the safety filter with every third replacement of the primary filter, or if damaged or dirty.

5. Reinstall filter(s).
6. Reinstall air cleaner cover.

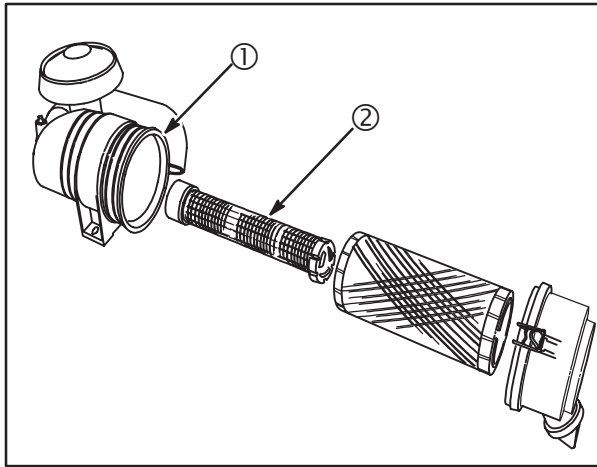


Fig. 5

## ARMATURE AIR GAP ADJUSTMENT

1. Loosen screws holding armature in place. Slide armature away from flywheel and tighten one of the screws.
2. Rotate flywheel until magnet is under armature laminations.
3. Place thickness gauge (1) between magnet and armature laminations, Fig. 6.
  - All EXCEPT Models 540000, 610000 – Use 0.008” – 0.012” (0.20 – 0.30 mm) gauge.
  - Models 540000, 610000 – Use 0.005 – 0.007” (0.13 – 0.18 mm) gauge.

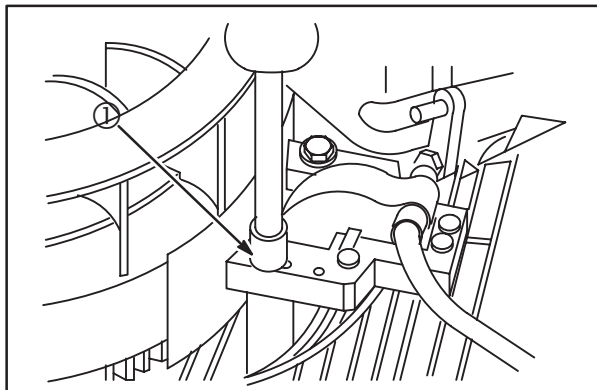


Fig. 6

4. Loosen screw on the armature. Allow armature to be pulled against the gauge by the flywheel magnet. Tighten both armature screws to **25 in. lbs. (3 Nm)**.
5. Rotate flywheel to remove gauge.
6. Repeat procedure for the other armature.

## CARBURETOR ADJUSTMENTS

### Models 290000 – 350000

The Vanguard™ OHV twin cylinder engine carburetor fuel mixture adjustment procedure is unique. Perform adjustments exactly in the sequence shown.

**NOTE:** If engine is equipped with Performance Control™ electronic governor see separate adjustment procedure.

### Initial Adjustment

1. Turn idle mixture screw (1), Fig. 7, CLOCKWISE until it just seats. DO NOT FORCE.
2. Turn valve COUNTERCLOCKWISE 1-1/4 turns.

This setting will permit engine to start. Final adjustment will be made with engine running.

**NOTE:** Parts removed for clarity.

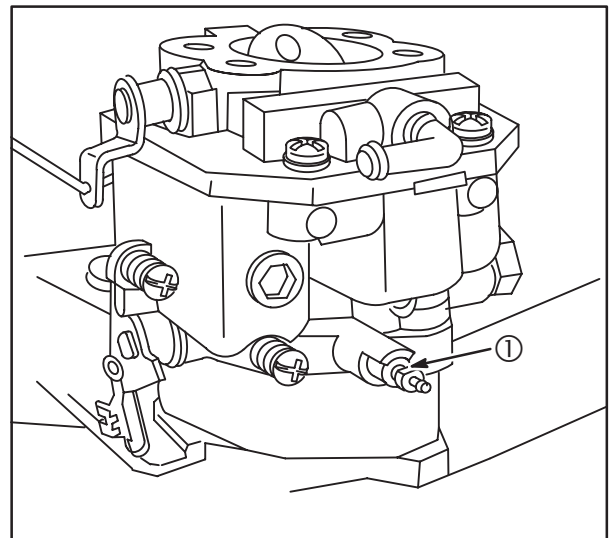


Fig. 7

If engine is equipped with a secondary governor spring, Fig. 8, check governor lever adjustment procedure before starting engine.

- (1) Primary Governor Spring
- (2) Loop (faces UP)
- (3) Secondary Governor Spring
- (4) Loop Over Tab
- (5) #2 Hole (Generators)
- (6) #1 Hole (Remote Control)

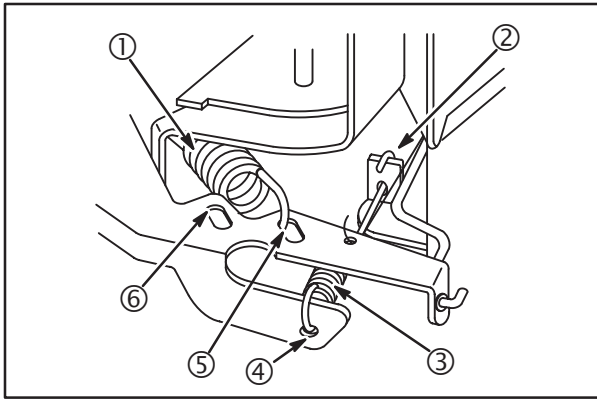


Fig. 8

### Final Adjustment

All carburetor adjustments performed with the engine running must be made with the air cleaner installed.

- Tools Required, Fig. 9:

Tachometer #19200 or #19389

Tang Bender #19352

1. Start engine. Run for approximately 5 minutes to allow engine to warm up.
2. Move control lever on equipment to SLOW position.

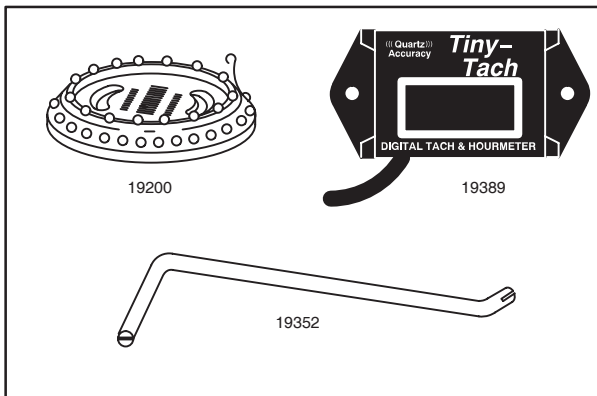


Fig. 9

3. Hold throttle lever (2) against idle speed screw (1), Fig. 10. Temporarily adjust idle to RPM shown below.
  - a. **1400 RPM** – Governed Idle Spring #805453 (RED).
  - b. **1100 RPM** – Governed Idle Spring #805454 (WHITE).

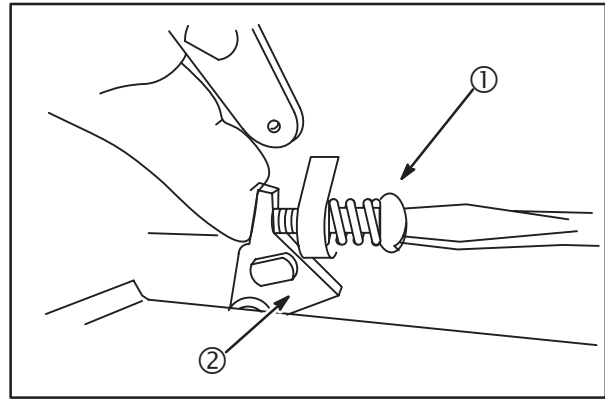


Fig. 10

4. Turn idle mixture screw slowly **CLOCKWISE** (1) until engine speed just starts to slow (LEAN mixture), Fig. 11.

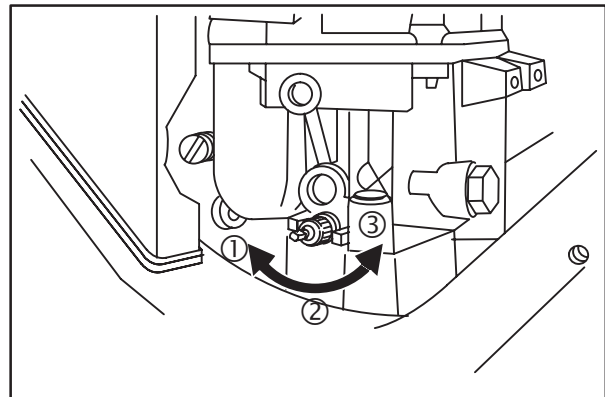


Fig. 11

5. Then turn idle mixture screw **COUNTER-CLOCKWISE** (3) until engine speed just starts to slow (RICH mixture).
6. Turn screw to mid point (2) between RICH and LEAN.
7. Hold throttle lever against idle speed adjustment screw and re-adjust idle to RPM shown below:
  - a. **1200 RPM** – Governed Idle Spring #805453 (RED).
  - b. **900 RPM** – Governed Idle Spring #805454 (WHITE).
8. Release throttle lever. Note RPM.
9. If necessary bend governed idle tang (5) with Tang Bender #19352 (4), Fig. 12, to obtain RPM shown:
  - a. **1750 RPM** – Governed Idle Spring #805453 (RED).
  - b. **1100 RPM** – Governed Idle Spring #805454 (WHITE).

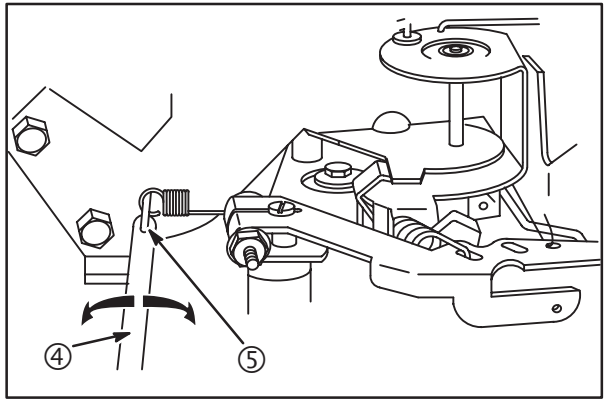


Fig. 12

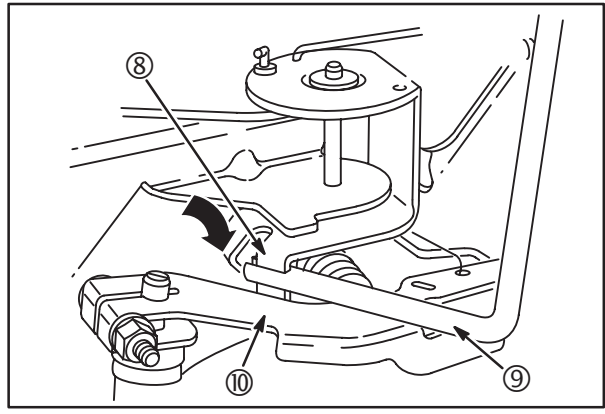


Fig. 14

10. If the carburetor is equipped with an idle mixture limiter cap install it at this time.

- a. Position limiter cap (7) so that stop(s) on limiter cap are at mid point between stop(s) on carburetor body, **Fig. 13**.

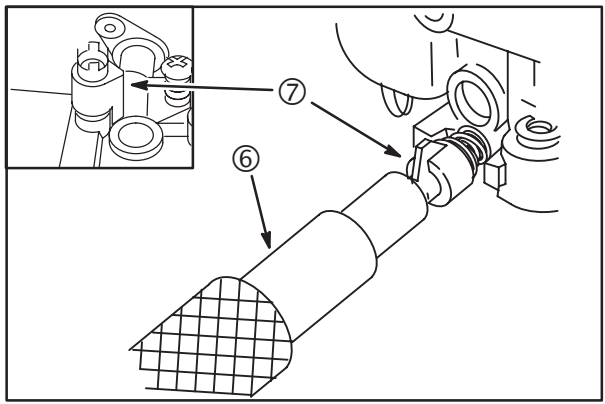


Fig. 13

- b. Press limiter into position using Knock Out Pin, #19135 (6) as shown.

11. With equipment control lever in SLOW position and engine running at governed idle, use Tang Bender, #19352 (9), to bend throttle restrictor tang (8) so that tang just contacts governor lever (10), **Fig. 14**.

12. Move equipment control to FAST position. Engine should accelerate smoothly.

Re-adjust idle mixture valve 1/8 turn richer if necessary.

**Performance Control™ Engines**

**NOTE:** All carburetor adjustments with engine running must be made with the air cleaner correctly installed.

1. Start engine and run it for approximately 5 minutes to allow engine to reach operating temperature.
2. Activate idle down device, or ground BLUE wire (1) from control module using a jumper wire (2), **Fig. 15**.
3. Temporarily adjust idle speed to **1400 RPM**.

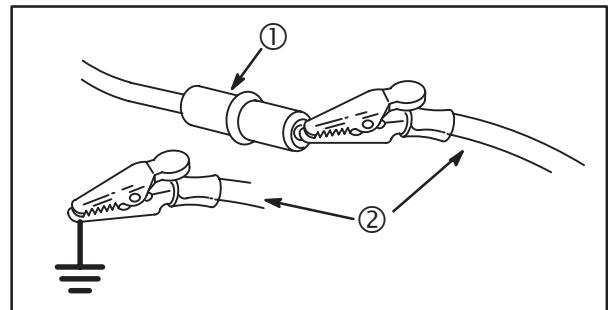
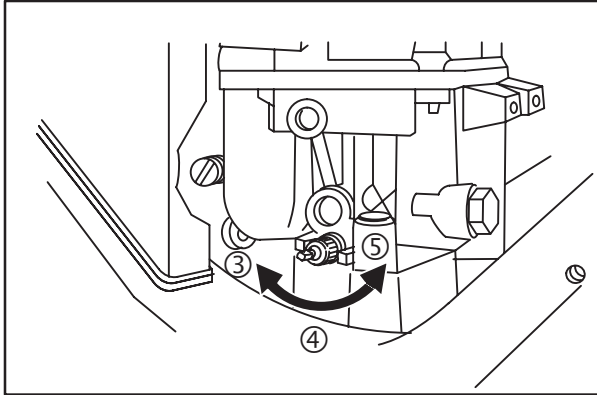


Fig. 15

4. Turn idle mixture screw slowly **CLOCKWISE** (3) until engine speed just starts to slow (**LEAN** mixture), **Fig. 16**.
5. Then turn idle mixture valve **COUNTERCLOCKWISE** (5) until engine speed just starts to slow (**RICH** mixture).
6. Turn valve to mid point (4) between **RICH** and **LEAN**.
7. Re-adjust idle speed to **1750 RPM**.

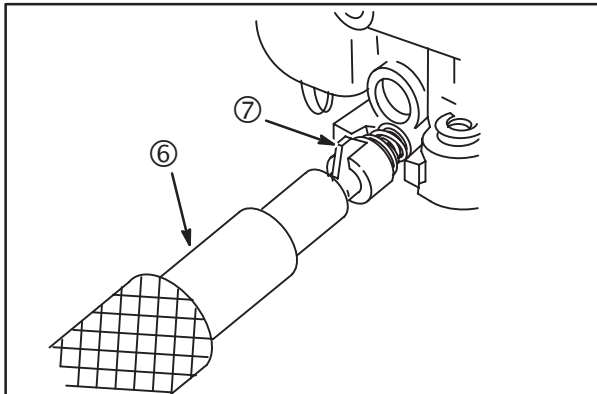
**NOTE:** Idle speed may vary according to OEM specifications.

1



**Fig. 16**

8. Deactivate idle-down device, or remove jumper wire. Engine should accelerate smoothly to top governed speed. Re-adjust idle mixture screw 1/8 turn richer if necessary.
9. If the carburetor is equipped with an idle mixture limiter cap, install it at this time.
  - a. Position limiter cap (7) so that stop on limiter cap is at mid point between stops on carburetor body, **Fig. 17**.



**Fig. 17**

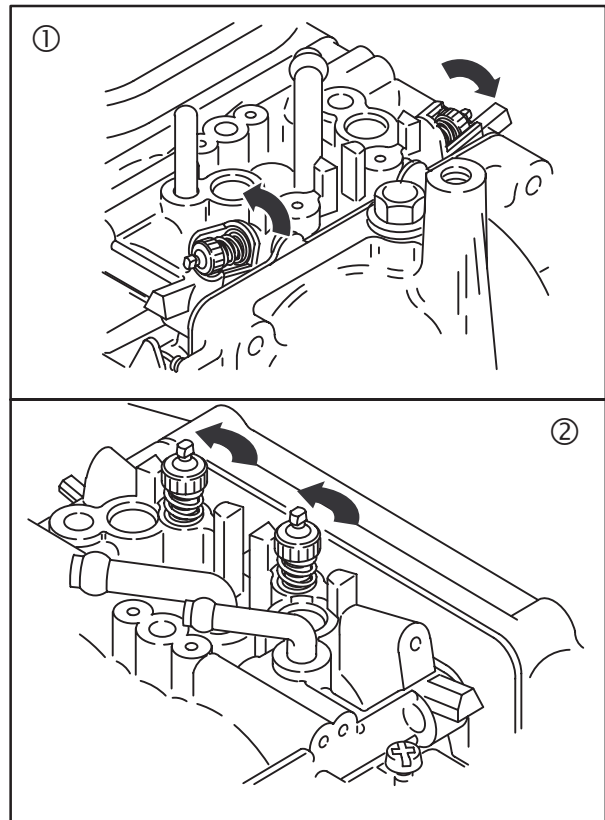
- b. Press limiter into position using Knock Out Pin #19135 (6).

**Models 351400, 380400, 351700 and 380700**

The OHV twin cylinder engine carburetor fuel mixture adjustment procedure is unique. Perform adjustments exactly in the sequence shown. Horizontal crankshaft engines (1) and vertical crankshaft engines (2) are shown in **Fig. 18**.

**Initial Adjustment**

1. Turn idle mixture screw for #1 cylinder **CLOCKWISE** until it just seats. **DO NOT FORCE**, **Fig. 18**.



**Fig. 18**

2. Then turn screw **COUNTERCLOCKWISE** 3/4 turn.
3. Repeat for #2 cylinder.

This setting will permit engine to start. Final adjustment will be made with engine running.

**Final Adjustment**

Carburetor adjustments performed with engine running must be made with the air cleaner correctly installed.

**NOTE:** Idle mixture adjustment **MUST** be performed with the engine running at **1200 RPM**.

**Tools Required:**

- Tachometer #19200 or #19389
- Tang Bender #19352

1. Start engine and run it for approximately 5 minutes to allow engine to reach operating temperature.
2. Move equipment control lever to **SLOW** position.
3. Hold throttle lever (1) against idle speed screw (2), **Fig. 19**. Temporarily adjust idle to **1200 RPM**.

4. While holding throttle lever, SLOWLY turn idle mixture screw for #1 cylinder CLOCKWISE until engine speed just starts to slow (LEAN mixture).

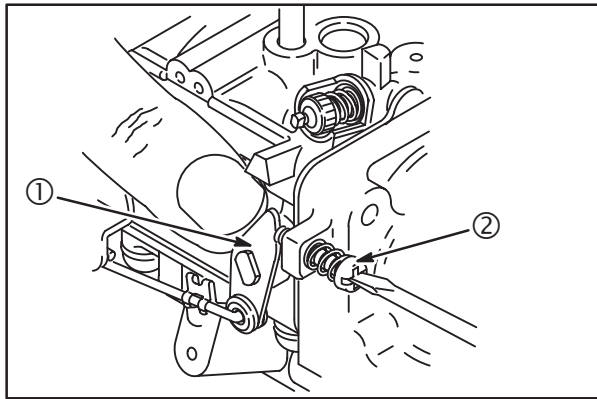


Fig. 19

5. Then turn idle mixture screw (3) COUNTER-CLOCKWISE 3/8 turn, Fig. 20.

**NOTE:** It may be necessary to re-adjust idle speed to 1200 RPM before proceeding.

6. Adjust idle mixture screw for #2 cylinder as described in steps 4 and 5.
7. If necessary, re-adjust idle speed screw to RPM shown below.
  - a. **1200 RPM** – Governed Idle Spring #805453 (RED).
  - b. **900 RPM** – Governed Idle Spring #805454 (WHITE).
8. Release throttle lever. Note RPM.

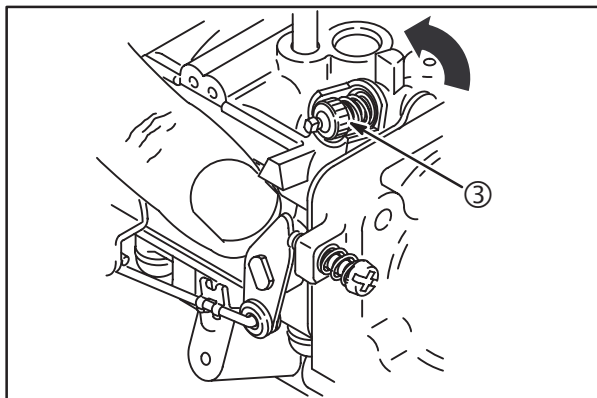


Fig. 20

9. If necessary, use Tang Bender #19352 (6), Fig. 21. Bend governed idle tang LEFT to INCREASE (4), right to DECREASE (5) engine speed to obtain RPM shown:

- a. **1750 RPM** – Governed Idle Spring #805453 (RED).
- b. **1100 RPM** – Governed Idle Spring #805454 (WHITE).

**NOTE:** Parts removed for clarity.

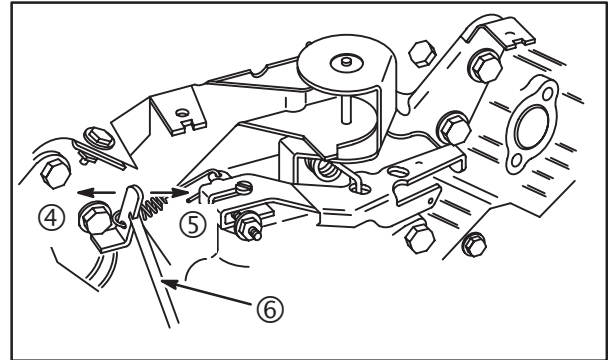


Fig. 21

10. If carburetor is equipped with idle mixture limiter caps, install at this time.
  - a. Position limiter cap (8) so that stop on limiter cap is at mid point between stops on carburetor body. Press limiter into position using Knock Out Pin #19135 (7) as shown in, Fig. 22.
  - b. Repeat for other idle mixture valve.

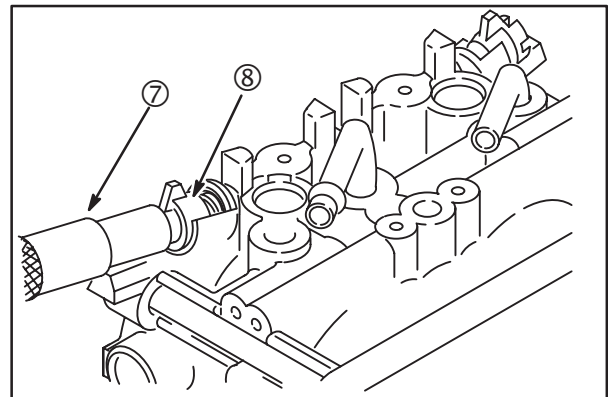


Fig. 22

11. With equipment control lever in SLOW position and engine running at governed idle, use Tang Bender #19352 (10), to bend throttle restrictor tang (9) so that it just contacts governor lever (11), Fig. 23.
12. Move equipment control to FAST position. Engine should accelerate smoothly. Re-adjust idle mixture valve 1/8 turn richer if necessary.



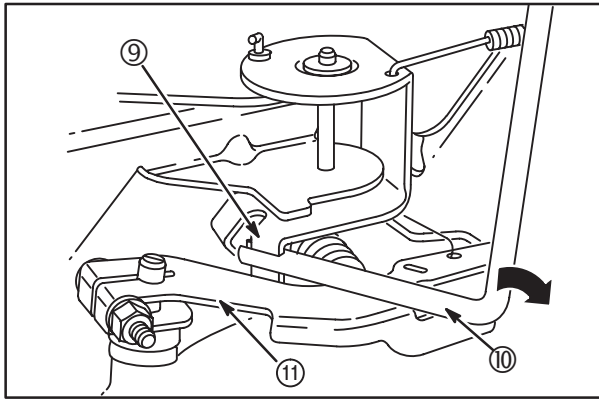


Fig. 23

## Choke Control Adjustment

**NOTE:** Be sure choke control wire is installed in #2 hole (2) in choke lever, **Fig. 24**.

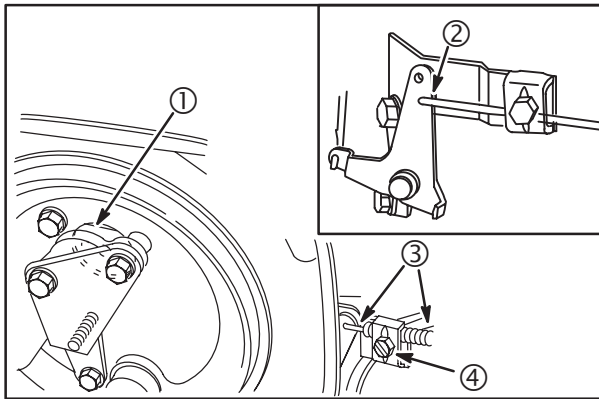


Fig. 24

1. Place choke control lever on equipment in CHOKE position.
2. Loosen control casing clamp screw (4).
3. Move control casing and wire (3) until choke is completely closed (1).
4. Tighten casing clamp screw.

## Combustion Chamber Deposits

Combustion chamber deposits should be removed every **500 hours** or whenever cylinder heads are removed.

	 <p><b>WARNING</b></p> <p><b>AVOID EYE INJURY!</b></p>
<p>• Wear eye protection whenever using compressed air to clean parts.</p>	

Remove deposits from combustion chamber and around valves using a wire brush or scraper. With piston at Top Dead Center (TDC), remove combustion chamber deposits from top of piston. Use care to prevent combustion chamber deposits from entering push rod or oil return cavity in cylinder.

Take care not to damage cylinder, top of piston, cylinder head and cylinder head gasket surfaces.

**NOTE:** Remove only the combustion chamber deposits. It is not necessary to remove the discoloration marks on the piston, valves and cylinder head. These marks are normal and will not affect engine operation.

Remove the loose deposits from around the top ring land area using compressed air or a soft bristle brush.

## Cooling System Cleaning

Grass particles, chaff or dirt can clog the air cooling system, especially after prolonged service in cutting dry grass or very dirty air. Operating with a clogged cooling system can cause overheating and engine damage. Cleaning the cooling system should be a regular maintenance operation, performed yearly or every **100 hours**, whichever comes first.

### All Except Models 540000, 610000

**Fig. 25** shows the blower housing removed and areas to be cleaned (1) on the Vanguard™ engine.

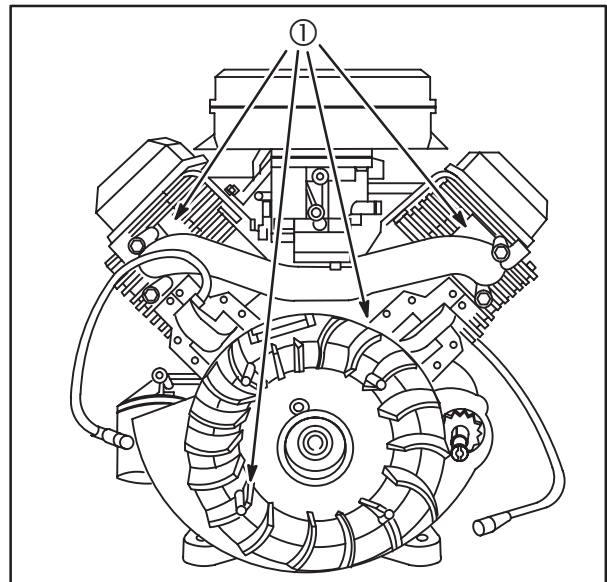
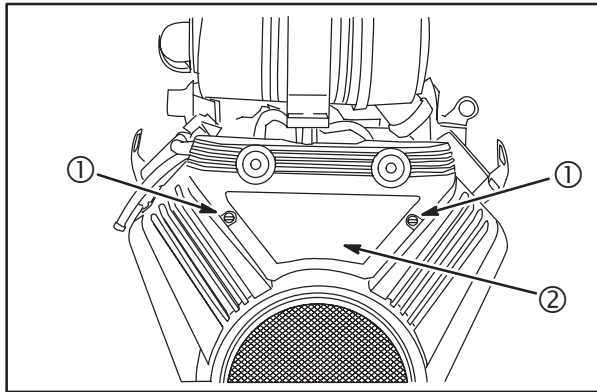


Fig. 25

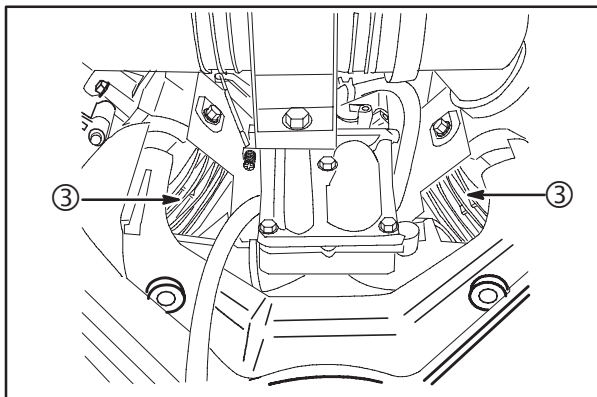
## Models 540000, 610000

1. Use a coin or screwdriver to twist the Easy Clean Access™ panel fasteners (1), **Fig. 26** COUNTERCLOCKWISE until a CLICK is heard (approx. 3/4 turn).
2. Remove the panel (2).



**Fig. 26**

3. Blow compressed air from the PTO side to clean the cooling fins (3), **Fig. 27** around each cylinder and to back flush the cooling system.



**Fig. 27**

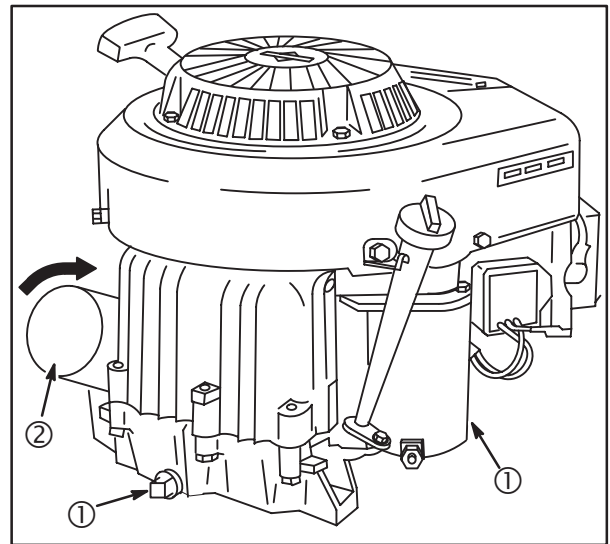
4. Insert the access panel tab into the blower housing slot. Be certain the access panel is correctly engaged to the blower housing. Push the panel completely into the housing. Twist each fastener COUNTERCLOCKWISE until it "CLICKS", approx. 3/4 turn.

**CAUTION:** DO NOT run the engine unless the Easy Clean Access™ panel is correctly installed.

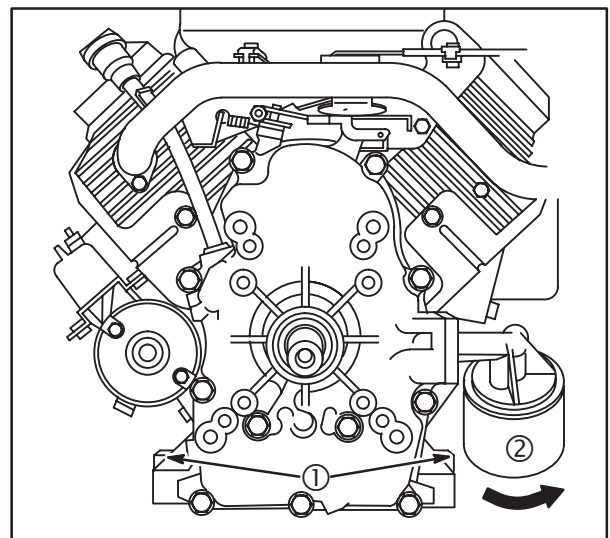
## Crankcase Oil

### Change Oil and Filter

Drain oil while the engine is still warm. See **Fig. 28** for approximate drain plug locations on vertical crankshaft engines; **Fig. 29** for horizontal crankshaft engines.



**Fig. 28**



**Fig. 29**

1. Remove oil drain plug (1). Drain oil into approved container.
2. Remove dipstick.
3. Replace oil filter (2) every **100** hours. Before installing new filter, lightly oil filter gasket with new engine oil.
4. Screw filter on COUNTERCLOCKWISE (arrow) by hand until gasket contacts filter adapter. Hand tighten an additional 1/2 - 3/4 turn.
5. Replace drain plug.
6. Refill crankcase slowly with new oil of proper service classification and viscosity grade. Refill to FULL mark on dipstick.

**CAUTION:** DO NOT OVERFILL THE ENGINE WITH OIL!



The crankcase capacity of Vanguard™ V-Twin engines is approximately:

- **All (except Model 540000) – 48 oz. (1.4 liters)** with filter
- **Models 540000, 610000 – 79 oz. (2.3 liters)** with filter
- **Models 540000, 610000 – 71 oz. (2.1 liters)** without filter

**NOTE:** When checking oil level, screw the dipstick all the way in for accurate readings.

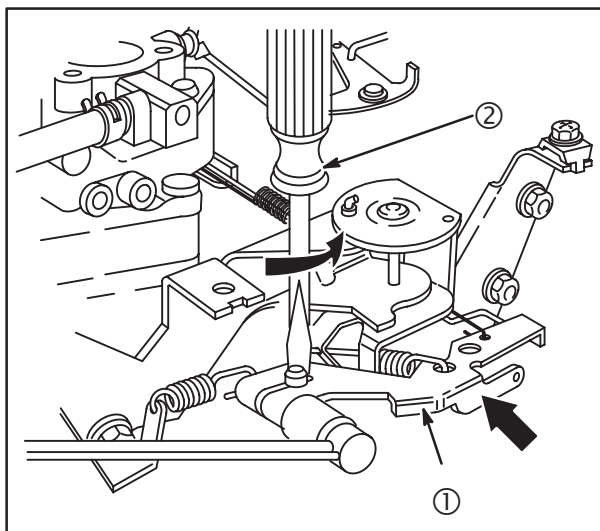
7. Start engine. Run at IDLE for 30 seconds and stop engine. Recheck oil level and add if required. Restart engine and check for oil leaks.

## Governor Adjustments

	 <b>CAUTION</b>
	<b>AVOID INJURY!</b> Complete the governor static adjustment <b>BEFORE</b> starting or running engine.
<ul style="list-style-type: none"> <li>• Incorrect adjustment could result in engine overspeeding, causing engine damage, property damage or personal injury.</li> </ul>	

### Static Governor Adjustment (Before Running Engine)

1. Loosen governor lever nut. Push on governor lever (1) until throttle is wide open, **Fig. 30**.



**Fig. 30**

**CAUTION:** Do not bend governor link or distort governor lever.

2. Use a screwdriver (2) to rotate governor shaft **COUNTERCLOCKWISE** as far it will go. Torque governor nut to **70 in. lbs. (8 Nm)**.
3. Install throttle and choke control cables and check for proper operation.

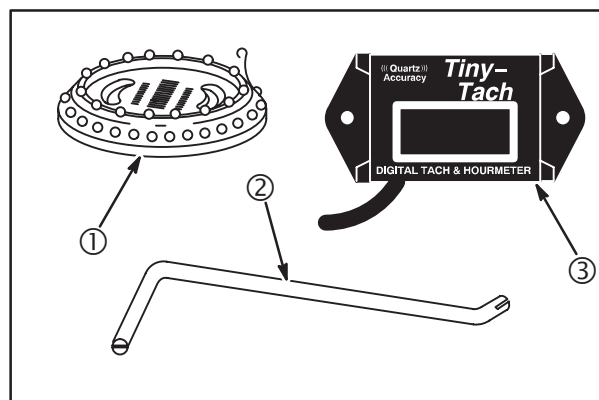
### Dynamic Governor Adjustment

**NOTE:** Carburetor mixture adjustments must be made before adjusting governed idle, throttle restrictor and top no-load RPM.

- Tools Required, **Fig. 31:**

Tachometer #19200 (1) or #19389 (3)

Tang bender #19352 (2)



**Fig. 31**

### Manual Friction and Remote Speed Controls

Governor spring is installed in #1 hole (3) in governor lever, **Fig. 32**.

Start and run engine for approximately 5 minutes to allow engine to warm up.

1. Move control lever to SLOW position.
2. Use tool #19352 (1) to bend governed idle tang (2) to obtain RPM shown:
  - a. **1750 RPM** – Governed Idle Spring #805453 (RED).
  - b. **1100 RPM** – Governed Idle Spring #805454 (WHITE).

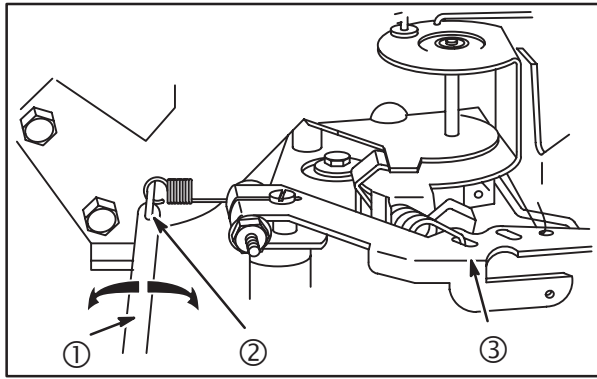


Fig. 32

3. With equipment control lever in SLOW position and engine running at governed idle RPM, use Tang Bender #19352 (1), to bend throttle restrictor tang (4) so that it just contacts governor lever (5), Fig. 33.

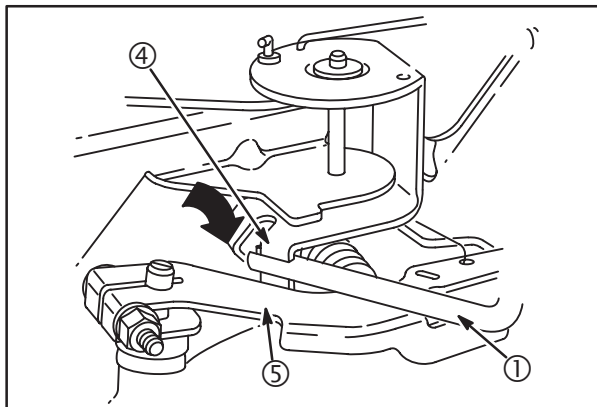


Fig. 33

4. Refer to Service Engine Sales Microfiche, MS-6225 or the Service Engine Sales Manual, MS-4052, for Top No-Load RPM by engine Model and Type Number.
5. Move control throttle lever to FAST position and check engine RPM.
6. Use Tool #19352 (1) to bend tang (6) UP (7) to increase and DOWN (8) to decrease engine speed, to obtain desired Top No-Load RPM, Fig. 34.

**NOTE:** Air cleaner removed for clarity.

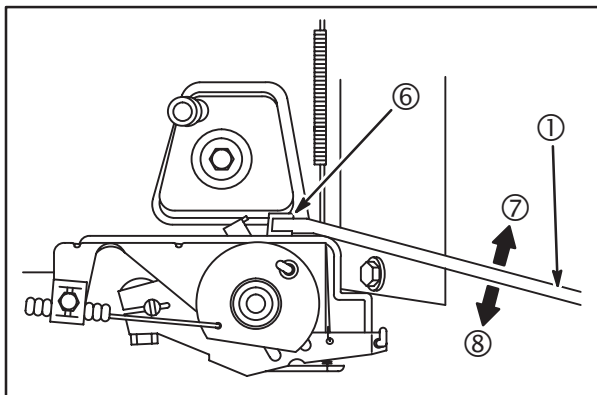


Fig. 34

### Fixed Speed Adjustable – Except Generators

Governor spring is installed in #1 hole in governor lever (3), Fig. 35.

Start and run engine for approximately 5 minutes to allow engine to warm up.

1. Turn fixed speed adjustable control nut counter-clockwise until control swivel contacts slow speed stop.
2. Use Tool #19352 (1) to bend governed idle tang (2) to obtain RPM shown:
  - a. 1750 RPM – Governed Idle Spring #805453 (RED).
  - b. 1100 RPM – Governed Idle Spring #805454 (WHITE).

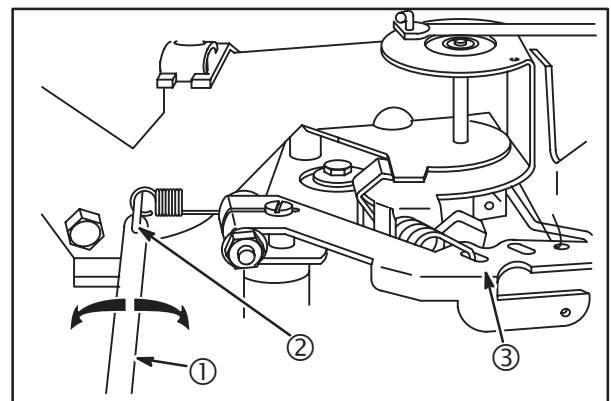


Fig. 35

3. Use Tool #19352 (1) to bend throttle restrictor tang (4) so that it just contacts governor lever (5), Fig. 36.

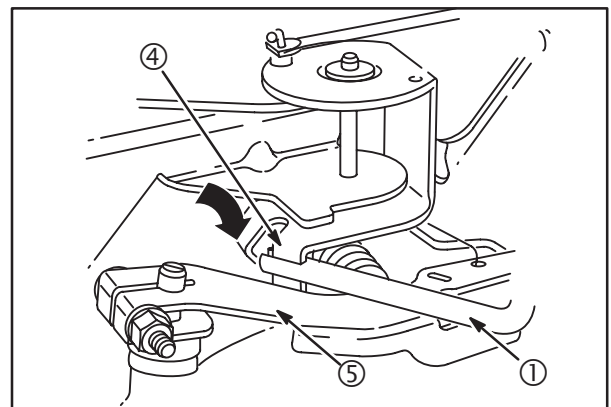
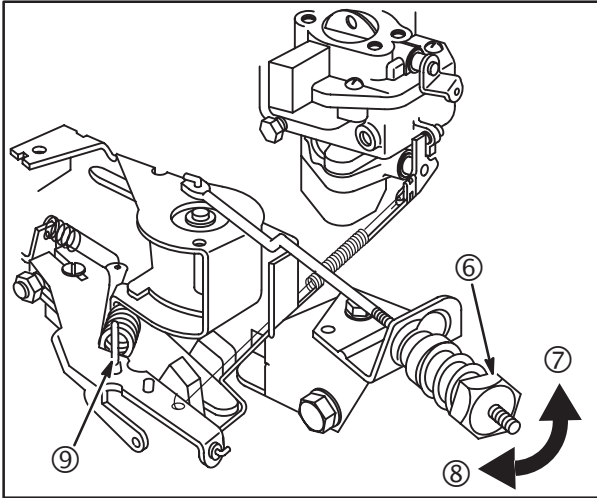


Fig. 36

**NOTE:** Be sure the governor spring is installed in #1 hole in governor lever (9), Fig. 37.

4. Refer to Service Engine Sales Microfiche, MS-6225 or the Service Engine Sales Manual, MS-4052, for Top No-Load RPM by engine Model and Type Number.

- Turn fixed speed adjustable control nut (6) clockwise (8) to increase or counter-clockwise (7) to decrease engine speed until desired Top No-Load RPM is obtained, **Fig. 37**.

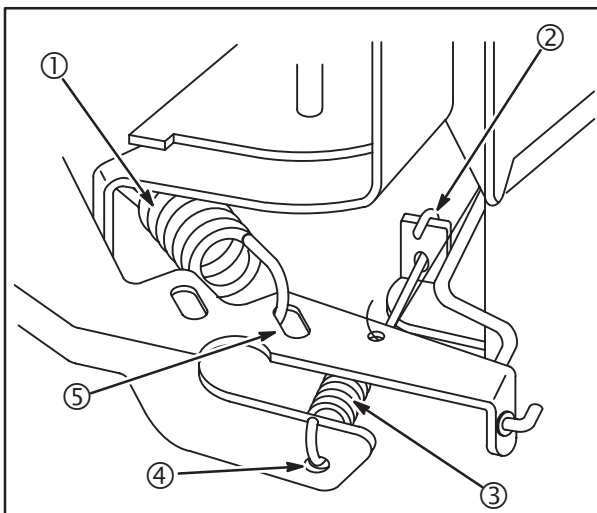


**Fig. 37**

### **Fixed Speed Adjustable – Generators**

No governed idle spring is used with this system. No throttle restrictor adjustment is necessary. The primary governor spring (1) is installed in #2 hole on governor lever (5). A secondary governor spring (3) is installed with loop (4) over the governor lever tab (4), and the rear loop facing (2) UP as shown in **Fig. 38**.

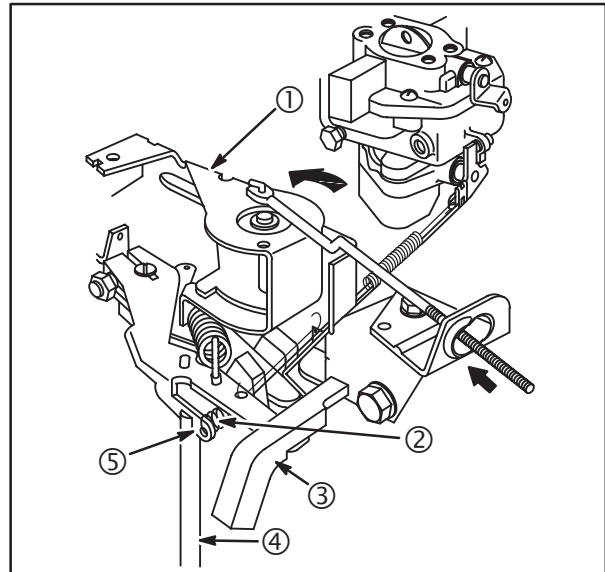
**NOTE:** Secondary governor spring must be adjusted **BEFORE** the engine is started. Perform adjustment in the sequence shown.



**Fig. 38**

### **Adjust Secondary Governor Spring**

- Disengage the adjustable fixed speed control nut (Inset, **Fig. 40**).
- Loosen and remove fixed speed adjustable control nut, spring and retainer.
- Rotate governor control swivel (1) counterclockwise to end of travel, **Fig. 39**.
- Install Adjustment Gauge #19385 (3), with notch over end of governor lever and flat end of tool against governor control bracket as shown in **Fig. 39**.
- Hold gauge in position and bend tab (5) with Tang Bender #19352 (4) so that all slack is removed from secondary governor spring (2) between its two anchor points, **Fig. 39**. **DO NOT STRETCH SPRING.**
- Remove adjustment gauge.



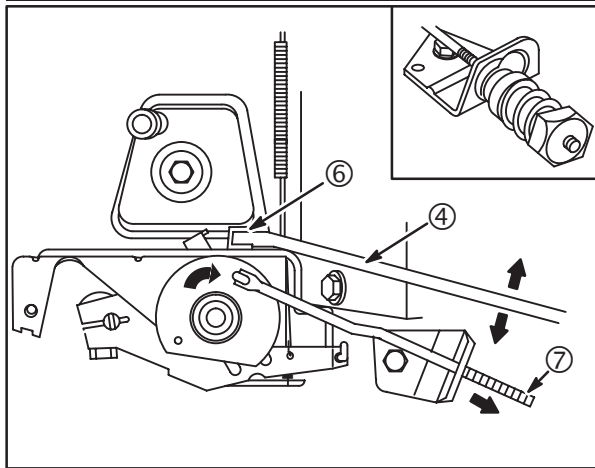
**Fig. 39**

Start engine. Run for approximately 5 minutes to allow engine to warm up.

- With engine running, pull control rod (7) out until swivel is against stop. Hold in this position, **Fig. 40**.
- Use tang bender (4) to bend tang (6). Adjust to Top No-Load RPM for the type of generator listed in Table 1.
- Re-install control nut, spring and retainer. Turn nut clockwise until threads on control rod are visible from end of nut, inset **Fig. 40**.

**TABLE NO. 1**

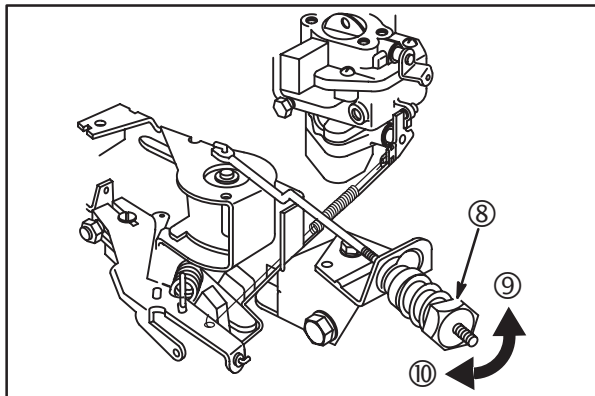
Generator Type	Top No-Load RPM	Regulated No-Load RPM
3600 RPM 60 Cycle	4250 RPM	3750 RPM
3000 RPM 50 Cycle	3600 RPM	3150 RPM



**Fig. 40**

10. Engage fixed speed adjustable control nut (8) and adjust to Regulated No-Load RPM for the type of generator listed in Table 1, **Fig. 41**.
  - a. Turn nut **CLOCKWISE** (10) to increase speed.
  - b. Turn nut **COUNTERCLOCKWISE** (9) to decrease speed.

**NOTE:** Final adjustment should be made with generator loaded to rated capacity or to manufacturer's specifications.



**Fig. 41**

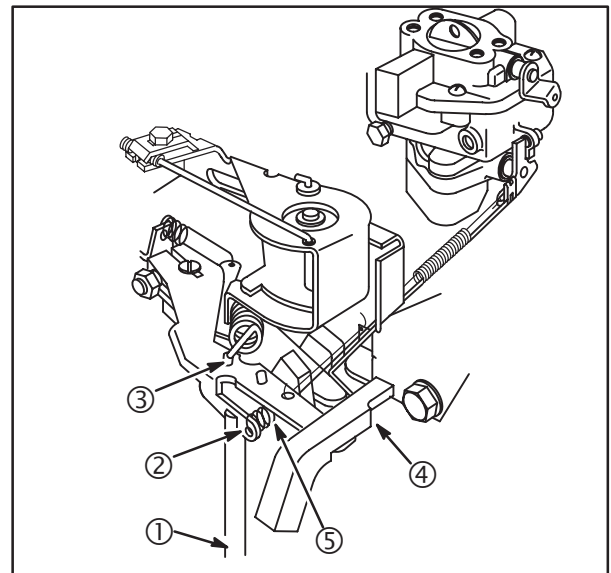
### Remote Speed Control Engines Equipped With Secondary Governor Spring

Some Vanguard™ OHV V-Twin engines with remote speed control are equipped with a secondary governor spring (5). The primary governor spring is installed in #1 hole (3) on governor lever, **Fig. 42**.

**NOTE:** The secondary governor spring must be adjusted **BEFORE** the engine is started. Perform the adjustment in the sequence shown.

### Adjust Secondary Governor Spring

1. Move equipment control to SLOW position.
2. Install Adjustment Gauge #19385 (4), with notch over end of governor lever and flat end of tool against governor control bracket as shown in **Fig. 42**.
3. Hold gauge in position and bend tab (2) with Tang Bender #19532 (1), so that all slack is removed from secondary governor spring (5) between its two anchor points, **Fig. 42**. **DO NOT STRETCH SPRING**.
4. Remove adjustment gauge.



**Fig. 42**

Start engine. Run for approximately 5 minutes to allow engine to warm up.

5. Move control lever to SLOW position.
6. Use tang bender (1) to bend governed idle tang (6) to obtain RPM shown, **Fig. 43**:
  - a. **1750 RPM** – Governed Idle Spring #805453 (RED).
  - b. **1100 RPM** – Governed Idle Spring #805454 (WHITE).

**NOTE:** Engine Model 303447 Type 0411-01 – Set governed idle to **1350 RPM ± 50 RPM**.

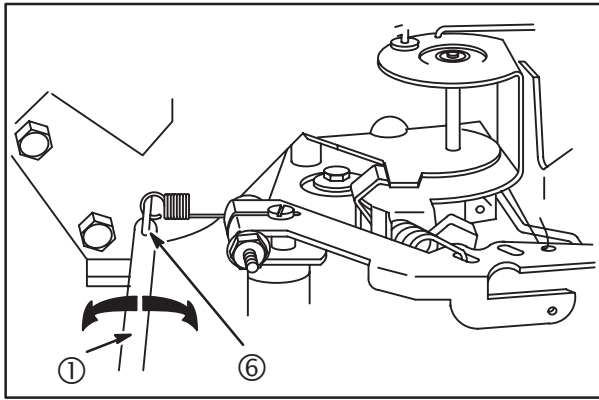


Fig. 43

7. With equipment control lever in SLOW position and engine running at governed idle RPM, use Tang Bender #19352 (1), and bend throttle restrictor tang (7) so that tang just contacts governor lever (8), Fig. 44.

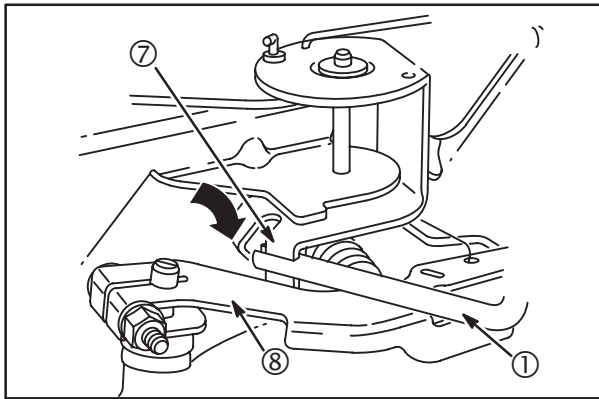


Fig. 44

8. Refer to Service Engine Sales Microfiche, **MS-6225** or the Service Engine Sales Manual, **MS-4052**, for Top No-Load RPM by engine Model and Type Number.
9. Move control throttle lever to FAST position and check engine RPM.
10. Bend tang (8) with Tool #19352 (1) to obtain desired top no-load RPM, Fig. 45.

**NOTE:** Engine Model 303447 Type 0411-01 – Set Top No-Load Speed to **2900 RPM ± 50 RPM**.

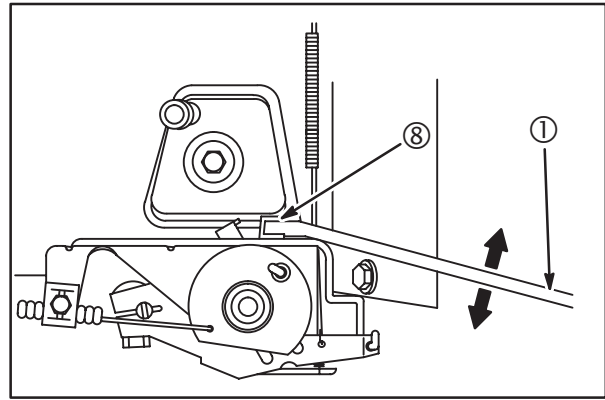


Fig. 45

## Oil Cooler

Some engines are equipped with an oil cooler, Fig. 46. The oil cooler is mounted on the blower housing. Filtered oil is routed through the oil cooler through two oil lines from a special oil filter adapter. Forced air from the flywheel fan flows through the oil cooler fins dissipating heat from the engine oil.

The oil cooler fins should be cleaned every **100** hours, checked periodically for debris, and cleaned with compressed air or a soft bristle brush.

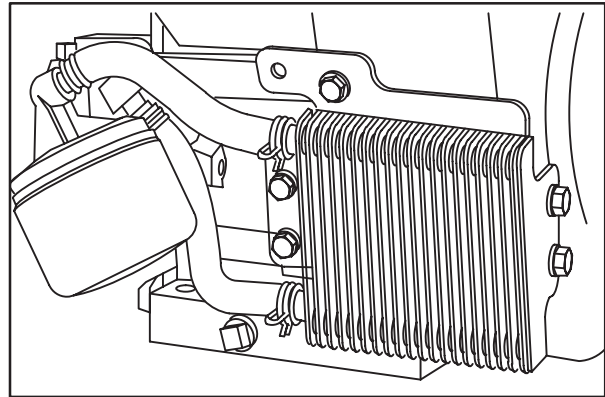


Fig. 46

## Spark Plugs

Replace spark plugs every **100** hours of operation or every season, whichever occurs first. Replace spark plugs if electrodes are burned away, or if the porcelain is cracked.

**NOTE:** Do not blast-clean spark plugs. Spark plugs should be cleaned by scraping or hand wire brushing and washing in a commercial solvent.

Use a wire gauge (1) to set spark plug gap, Fig. 47.

Torque spark plugs to **180 in. lbs. (20 Nm)**.

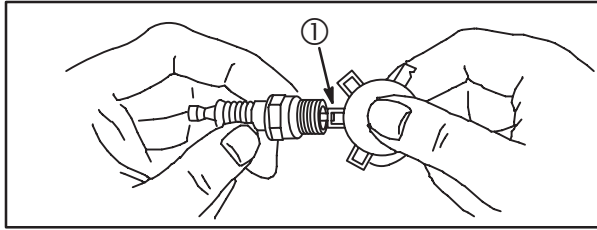


Fig. 47

### All Except Models 540000, 610000

Resistor spark plugs recommended by Briggs & Stratton:

- B&S #491055 (Champion RC12YC) or
- B&S #496018 (Champion RC14YC)

Gap to **0.030" (0.76 mm)**.

### Models 540000, 610000

Resistor spark plug recommended by Briggs & Stratton:

- B&S #692051

Gap to **0.020" (0.51 mm)**.

### Speed Control Wire Adjustment

**NOTE:** Manual friction and remote control adjustment procedure is identical.

1. Loosen control casing clamp screw (1) at governor control bracket, **Fig. 48**.
2. Move speed control lever to FAST position (inset, **Fig. 48**).
3. Move control casing and wire until governor control swivel is at end of travel.
4. Tighten casing clamp screw.

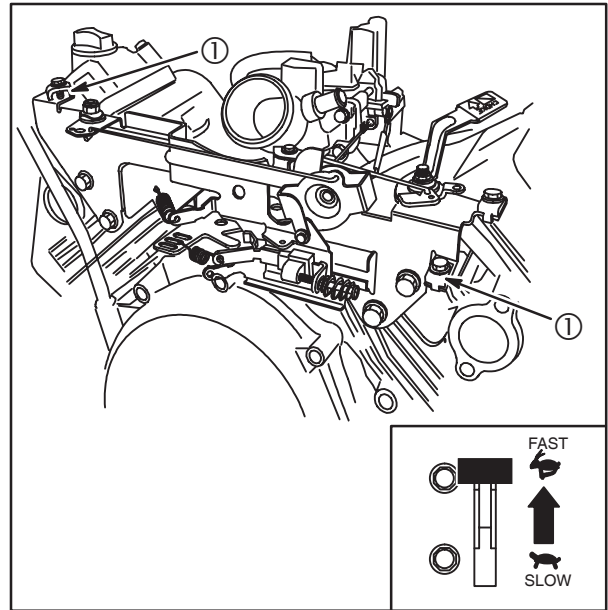


Fig. 48

### Valve Clearance Adjustment

1. Set No. 1 cylinder at **1/4" (6 mm)** past TDC, compression stroke.
2. Use a feeler gauge (1) to measure the valve clearance. Valve clearance should be **0.005" (0.13 mm)** for the intake and exhaust valve.

**NOTE:** Measure valve clearance with the engine **COLD**.

3. If the valve clearance requires adjustment, loosen the lock nut (2) with a wrench (4). Use a hex wrench (5) to turn the adjusting screw (3) to adjust the valves, **Fig. 49**.
4. With the valve clearance correctly adjusted, hold the adjusting screw. Torque the lock nut to **70 in. lbs. (8 Nm)**.
5. Repeat for No. 2 cylinder.

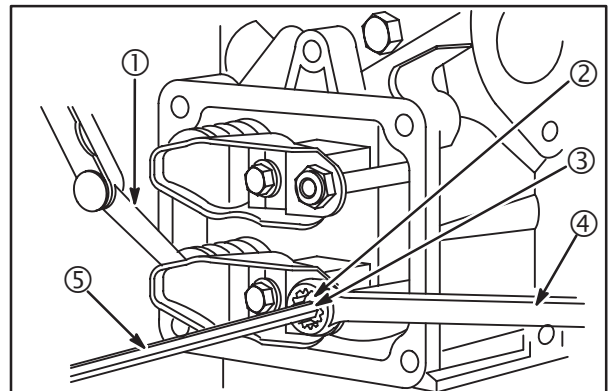


Fig. 49



## TUNE-UP PROCEDURE

1

A "Tune-Up," see the steps listed below, would normally be performed on relatively new engines brought in for minor difficulties. By performing these steps you will either be sure that the engine is functioning properly or will know what major repairs should be made. The steps are also covered in the Overhaul Procedure and will normally be performed as a part of the complete overhaul.

1. Disconnect and ground spark plug wires.
2. Remove air cleaner cartridge, check for proper servicing. Check gaskets, pre-cleaner and cartridge for damage.
3. Check oil level. Drain oil. Remove oil filter.
4. Remove blower housing, inspect rewind assembly when equipped.
5. Clean cooling fins and entire engine.
6. Check governor, linkage and springs for damage and wear. Check governor adjustment.
7. Remove intake manifold and carburetor. Disassemble carburetor. Wash in solvent and inspect for wear or damage. Replace gaskets and parts as necessary. Reinstall carburetor on manifold. Set initial adjustment.
8. Replace spark plugs. Remove flywheel. Check flywheel key. Check for oil seal leakage on both flywheel and PTO sides.
9. Check coils. Inspect all wires for breaks and/or damaged insulation. Be sure ground wires do not touch flywheel. Check ground wire and stop switch connections.
10. Remove cylinder heads. Remove carbon. Check head gaskets. Inspect valves for seating.
11. Install cylinder heads and new gaskets. Tighten to specified torque. Adjust valve clearance. Set spark plug gaps.
12. Reinstall intake manifold using new gaskets.
13. Reinstall blower housing.
14. Install new oil filter. Replace oil and fuel.
15. Adjust equipment control and cables, if used, for correct operation.
16. Service air cleaner pre-cleaner and cartridge, or replace.
17. Check muffler for restrictions or damage.
18. Start engine and bring up to operating temperature. Then, adjust carburetor mixture and engine top speed.

---

## OVERHAUL PROCEDURE

The following Overhaul Procedure is intended to help you to establish a systematic method of repairing Briggs & Stratton OHV engines. These steps may be performed in a different order but best efficiency is obtained when the repairs are performed in the same sequence every time. The exact procedure will vary according to the engine model being repaired. Be careful to locate the instructions covering the specific model being repaired.

### Disassemble

1. Drain oil. Remove oil filter.
2. Remove spark plugs.
3. Air cleaner assembly (if equipped).  
Fuel tank and bracket assembly (if equipped).  
Fuel pump and bracket (if equipped).
4. Rotating screen (if equipped). Blower housing.
5. Rewind starter (if equipped).
6. Exhaust manifold, muffler(s).
7. Intake manifold and carburetor.
8. Check throttle shaft and bushings for wear.
9. Disassemble carburetor.
10. Check armature air gap. Remove armatures.
11. Flywheel.
12. Electric starter.
13. Breather. Valve covers and valley cover.
14. Governor control bracket.
15. Check valve clearances.
16. Cylinder shields, rocker arms, push rods, cylinder heads.
17. Valves, springs and seals. Inspect valve guides and seats.
18. Check crankshaft end play. Remove burrs from crankshaft extension.
19. Crankcase cover. Inspect bearings. Remove oil seal.
20. Cam gear and tappets. Inspect governor.
21. Connecting rods and pistons.
22. Inspect crankshaft.

23. Cylinder – check cylinder bores and bearings. Remove oil seal.
24. Disassemble and check connecting rods, pistons, piston pins and rings.
25. Disassemble and inspect oil pump.

### **Inspection and Repairs**

1. Clean parts.
2. Resize cylinder bore as required.
3. Replace main bearing.
4. Replace all oil seals.
5. Replace valve guides.
6. Reface and lap valves and seats.
7. Replace armatures.
8. Repair carburetor.
9. Replace rewind starter spring and rope (if equipped)

### **Reassemble**

1. Crankshaft.
2. Pistons, piston pins, rings and connecting rods.
3. Tappets, cam gear.
4. Mechanical governor.
5. Oil pump.
6. Crankcase cover – check end play. Replace oil seal.

7. Electric starter.
8. Flywheel and starter pulley (if equipped).
9. Armatures – adjust air gap.
10. Check spark.
11. Valves, seals, springs and retainers.
12. Cylinder heads, push rods, rocker arms and cylinder shields.
13. Adjust valve clearance.
14. Valve covers, breather and valley cover.
15. Linkage and governor controls.
16. Carburetor and intake manifold.
17. Check and adjust mechanical governor.
18. Blower housing.
19. Fuel pump and bracket (if equipped).  
Fuel tank and bracket (if equipped).
20. Clean and assemble air cleaner.
21. Exhaust manifold, mufflers.
22. Install new spark plugs.
23. Replace oil filter. Fill crankcase with oil. Fill with gas. Start engine.
24. Adjust carburetor.
25. Adjust governor controls to obtain correct engine speed (remote controls).
26. Re-torque cylinder head screws.
27. Spray paint engine and apply decals.



# Section 2

## Troubleshooting

	Page
<b>ELECTRICAL SYSTEMS</b> .....	<b>32</b>
<b>Alternators</b> .....	<b>32</b>
Alternator System Diagnosis .....	32
Charging System Identification .....	33
Flywheel Magnet Identification .....	34
Equipment Used to Test Alternators .....	34
<b>Testing Alternator Output</b> .....	<b>35</b>
AC Alternator .....	35
DC Alternator .....	36
Dual Circuit Alternator .....	37
Tri-Circuit Alternator .....	38
5 & 9 Amp Regulated Alternator .....	40
10 & 16 Amp Alternator .....	41
20 Amp Regulated Alternator .....	43
<b>Powerlink System</b> .....	<b>45</b>
<b>Anti-Afterfire Solenoid</b> .....	<b>47</b>
<b>Testing Battery</b> .....	<b>48</b>
<b>Testing Engine Wiring Harness</b> .....	<b>50</b>
<b>Oil Pressure</b> .....	<b>53</b>
<b>Panel Kit with Key Switch and Solenoid</b> .....	<b>53</b>
<b>Starter Motor</b> .....	<b>56</b>
Conditions Affecting Starter Motor Performance .....	56
Troubleshooting .....	56
Testing .....	56
Solenoid Test .....	57
<b>Performance Control™ Electronic Governor</b> .....	<b>58</b>
Wiring Diagram .....	58
Governor Test .....	59
Replacing Actuator .....	59
<b>EQUIPMENT PROBLEMS AFFECTING ENGINE OPERATION</b> .....	<b>64</b>
<b>GASEOUS-FUELED ENGINES</b> .....	<b>61</b>
<b>Troubleshooting Guide</b> .....	<b>61</b>
<b>Carburetor Adjustment</b> .....	<b>63</b>
<b>LPG-Only Operation</b> .....	<b>63</b>
<b>SYSTEMATIC CHECK</b> .....	<b>28</b>
<b>Ignition</b> .....	<b>28</b>
<b>Carburetion</b> .....	<b>29</b>
<b>Compression</b> .....	<b>29</b>

Most complaints concerning engine operation can be classified as one or more of the following:

1. Will not start
2. Hard starting
3. Lack of power
4. Runs rough
5. Vibration
6. Overheating
7. High oil consumption

**NOTE:** What appears to be an engine problem may actually be the fault of the powered equipment. If equipment is suspect, see Equipment Affecting Engine Operation.

## SYSTEMATIC CHECK



A systematic check of the engine can be performed in minutes, and is an accurate method of determining the source of the problem. The basic procedure is the same for all engine models. Variations, by model, will be shown under the subject heading. If the engine will not start and the cause is not apparent, perform a systematic check in the following order:

1. Ignition
2. Carburetion
3. Compression

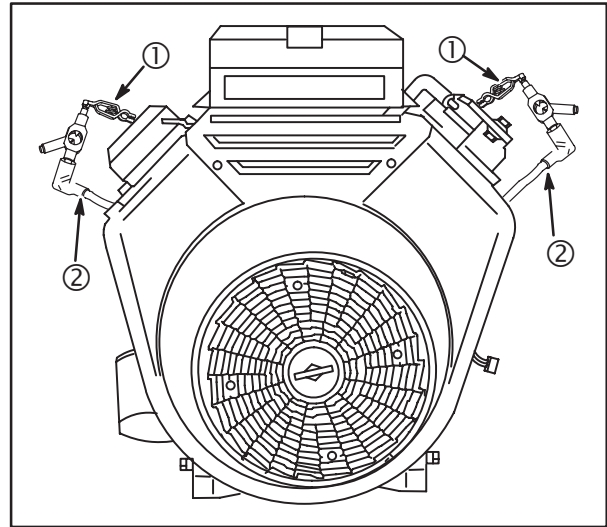
## Ignition

### Test Using Electric Starter

**NOTE:** Magnetron® ignition systems require a minimum of **350 RPM** to produce spark.

	 <b>WARNING</b>
<b>AVOID ELECTRICAL SHOCK!</b>	
<ul style="list-style-type: none"> <li>• A partially sheared flywheel key will affect ignition timing and engine performance.</li> <li>• Spark can still occur with a sheared flywheel key. A severe shock or kickback hazard may exist.</li> </ul>	

With spark plugs installed, attach Ignition Tester #19368 (1) to each spark plug (2). Ground the other end of the tester as shown, **Fig. 1**. Spin the flywheel rapidly with engine starter. If spark jumps the tester gap the ignition system is working correctly.



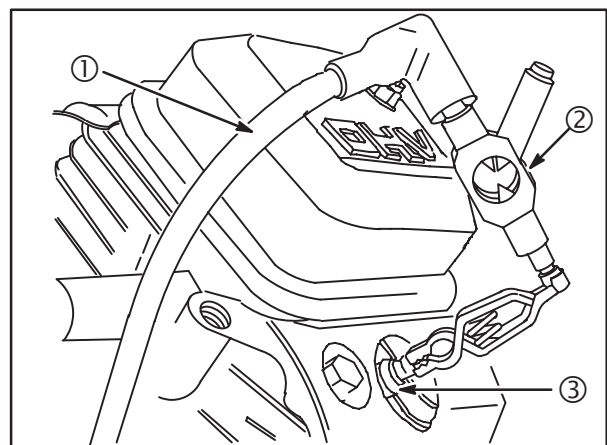
**Fig. 1**

If there is **NO SPARK** look for –

1. Improperly operating equipment interlock system
2. Shorted equipment stop switch wire
3. Two closed diodes in ground wire harness (current style) or ground terminal (early style)
4. Incorrect armature air gap
5. Armature failure

### Test With Engine Running

If the engine runs, but misses under load, test the ignition by installing an Ignition Tester #19368 (2) between the spark plug lead (1) and each spark plug (3), **Fig. 2**. A spark miss will be readily apparent when the engine is running. If the spark appears good in the tester but the engine misses, check for a fouled spark plug.



**Fig. 2**

### Fouled Plug or Dead Cylinder

To test for a fouled spark plug or a non-functioning cylinder, attach Ignition Tester #19368 (2) between the spark plug lead (1) and each spark plug (4). With engine running at top no-load speed, use a screwdriver (3) with an insulated handle to ground one spark plug by contacting the alligator clip on the ignition tester to a good ground on the engine, **Fig. 3**. The engine should continue to run on the other cylinder. Repeat this test with the other cylinder. If the engine dies when performing this test, the cylinder that is NOT grounded is not functioning and/or the spark plug is fouled. Install a new spark plug and re-check. If miss continues see the following procedures.

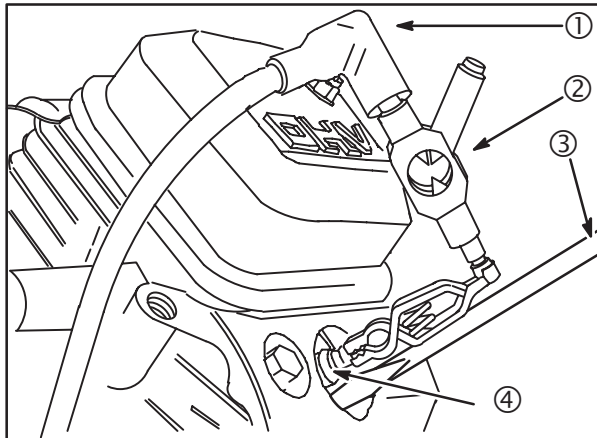


Fig. 3

### Carburetion

**NOTE:** Gaseous fuel engines use carburetors that must be serviced by a certified gaseous fuel installer or by a certified dealer for the equipment powered.

Before performing a carburetion check, be sure the fuel tank has an ample supply of fresh, clean gasoline. Be sure that the shutoff valve, if equipped, is open and fuel flows freely through the fuel line before starting engine. Inspect and adjust the idle needle valve. Make sure the choke closes completely. If engine will not start, remove and inspect the spark plugs.

#### If plugs are wet, look for –

1. Overchoking
2. Excessively rich fuel mixture
3. Water in fuel
4. Float needle valve stuck open
5. Plugged air cleaner

#### If plugs are dry, look for –

1. Leaking carburetor mounting gaskets
2. Gummy or dirty carburetor, fuel line or tank
3. Float needle valve stuck shut
4. Inoperative fuel pump
5. Inoperative anti-afterfire solenoid

To determine if fuel is getting to the combustion chamber through the carburetor, remove either spark plug and pour a small quantity of gasoline through the spark plug hole. Replace the spark plug. If the engine fires a few times and then stops, look for the same conditions as for a dry plug.

### Compression

#### Compression Test

Briggs & Stratton does not publish compression pressures, as it is difficult to obtain an accurate reading without special equipment. An assessment of the engine's compression can be made as follows:

Remove both spark plugs and insert a compression gauge into either cylinder (one cylinder at a time). Turn engine over with engine starter until there is no further increase in gauge pressure reading. Record this reading. Repeat procedure on other cylinder and record that reading. Divide the difference between the cylinders by the compression pressure of the higher of the two cylinders. A difference over **25%** between the cylinders indicates a loss of compression in the cylinder with lower pressure. See example below.

	Engine #1	Engine #2
Cylinder #1	65 PSI	75 PSI
Cylinder #2	60 PSI	55 PSI
Difference	5 PSI	20 PSI
% Difference	7.7%	26.7%

If compression is poor, look for –

1. Loose cylinder head bolts
2. Blown head gasket
3. Burned valves, burned and/or loose valve seats
4. Insufficient valve clearance
5. Warped cylinder head
6. Warped valve stems
7. Worn bore and/or rings
8. Broken connecting rods

### Cylinder Leakdown Test



Use a leakdown tester to test the sealing capability of each cylinder. Follow the instructions for the leakdown tester you are using to determine the likely problem area(s).

1. Run engine for 5 minutes allowing engine to reach operating temperature.

**NOTE:** If the engine is cold or cannot be started, air flow may be higher (gauge readings lower) because compression components are not at normal operating temperatures.

2. Remove spark plug from engine. Disconnect crankcase breather tube.
3. Rotate crankshaft in direction of operation until piston is at Top Dead Center (TDC) of the compression stroke.
4. Hold flywheel nut with socket and breaker bar.

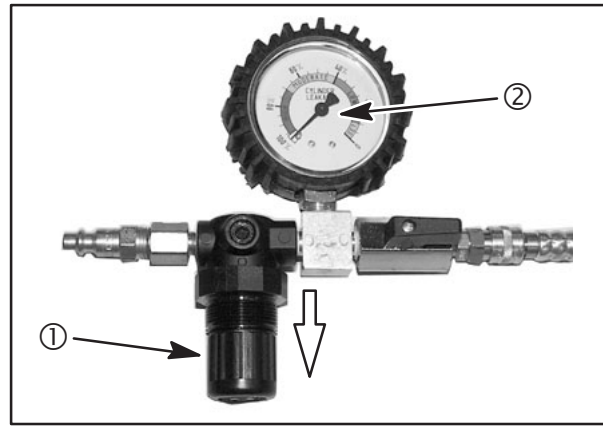
**NOTE:** Hold the crankshaft with the piston at TDC to minimize the chance of rotation.

	 <b>CAUTION</b>
	<b>AVOID INJURY!</b>
<ul style="list-style-type: none"> <li>• Injury could occur if the crankshaft is allowed to rotate or if the engine is not securely fastened to a stand or to the application.</li> </ul>	

5. Connect tester to a shop air source with minimum air pressure of **70 psi (480 kPa)**.
6. Install outlet hose into spark plug hole of cylinder being tested. Insure O-ring is seated to prevent air leak at spark plug hole. Connect other end to tester.
7. While securely holding the flywheel nut with the breaker bar and socket, pull the adjustment knob OUT (arrow), **Fig. 4**. Slowly turn the regulator adjustment knob (1) **CLOCKWISE** until tester needle (2) is on the set point. Push in regulator adjustment knob.

**NOTE:** Any air leaks at connections or fittings of tester will affect the accuracy of test.

8. Slowly open the valve and note the reading on the gauge.



**Fig. 4**

### Cylinder Balance Test

If the engine starts hard, runs rough, misses or lacks power, perform a cylinder balance test to determine whether both cylinders are operating correctly.

A cylinder balance test will also detect a cylinder that is not functioning. When grounding one cylinder there will be no RPM loss. When the other cylinder is grounded the engine will stop.

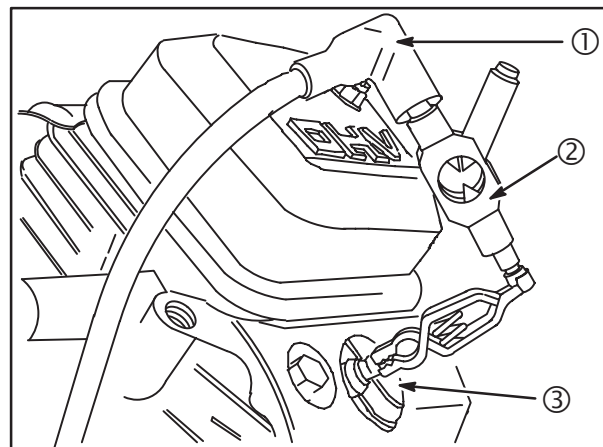
- Tools Required:

Tachometer #**19200**

Two @ Ignition Tester #**19368**

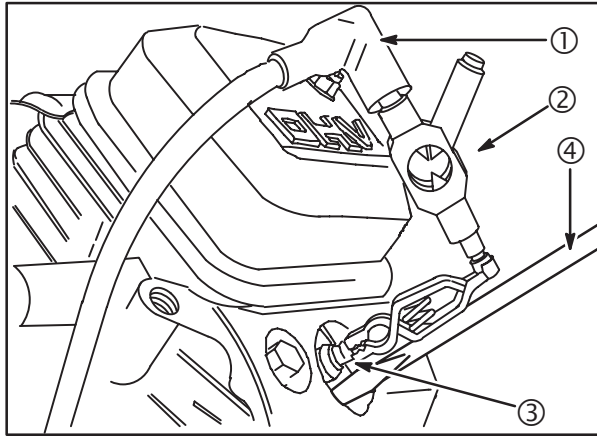
Screwdriver with insulated handle.

1. Attach Ignition Tester #**19368** (2) between each spark plug lead (1) and spark plug (3), **Fig. 5**.



**Fig. 5**

2. Start engine. Run at top no-load speed and note spark at ignition testers. If the spark is equal at both ignition testers, the problem is not ignition related. A spark miss should be readily apparent.
3. Note RPM of engine. Ground one cylinder with screwdriver (4) by contacting alligator clip on ignition tester to a good ground on engine, **Fig. 6**. Note RPM loss.



**Fig. 6**

4. Ground the other spark plug and again note the RPM loss.

If the difference between the two cylinders does **not exceed 75 RPM**, the amount of work the two cylinders are doing is considered equal.

An RPM loss **greater than 75 RPM** indicates that the cylinder with the lower RPM loss is the weaker of the two cylinders. Look to that cylinder for a problem. See example below.

Engine RPM – Both Cylinders = **3400 RPM**

Engine RPM – Cylinder #1 Grounded = **3300 RPM**

Engine RPM – Cylinder #2 Grounded = **3100 RPM**

Conclusion: Cylinder #1 is weaker cylinder.

**NOTE:** A partially sheared flywheel key will affect ignition timing and engine performance.

### ***Problems Affecting One Cylinder***

**NOTE:** A two cylinder engine will run on one cylinder as long as the power required for the application does not exceed the power produced by one cylinder.

1. Spark plug – A fouled spark plug may also indicate that carburetor is out of adjustment.
2. Spark plug wire
3. Head gasket
4. Intake manifold – A leak at either end of the intake manifold will affect only one cylinder.
5. Valves
6. Rings
7. Piston
8. Cylinder

### ***Problems Affecting Two Cylinders***

1. Carburetion
2. Crankcase vacuum
3. Ignition timing



## ELECTRICAL SYSTEMS

### Alternators

#### Alternator System Diagnosis

The following list is provided to help diagnose alternator system problems.

2

COMPLAINT	POSSIBLE CAUSES
Battery not charging	<ul style="list-style-type: none"><li>• Engine RPM too low.</li><li>• Inline fuse "blown" (if equipped).</li><li>• Defective battery.</li><li>• Loose, pinched, or corroded battery ground leads.</li><li>• Loose, pinched, or corroded battery charge leads.</li><li>• Open, shorted, or grounded wires between output connector and battery.</li><li>• Defective diode (open or shorted).</li><li>• Defective or improperly grounded regulator-rectifier.</li><li>• Diode installed incorrectly (reversed).</li><li>• Damaged battery (shorted battery cells).</li><li>• Excessive current draw from accessories.</li><li>• Low magnetic flux or damaged alternator magnets.</li></ul>
Battery overcharged	<ul style="list-style-type: none"><li>• Severe battery vibration (missing or broken tie-down straps).</li><li>• Battery rate of charge not matched to alternator output.</li><li>• Damaged battery (shorted battery cells).</li><li>• Defective regulator.</li><li>• One OHM resistor shorted or grounded (Tri-Circuit system only).</li></ul>
Headlamps not working	<ul style="list-style-type: none"><li>• Inline fuse "blown" (if equipped).</li><li>• Defective headlamps.</li><li>• Loose or corroded wires.</li><li>• Open, shorted or grounded wires between output connector and headlamps.</li><li>• Light switch defective.</li><li>• Defective diode Tri-Circuit system (open or shorted – white output lead side).</li><li>• Low magnetic flux or damaged alternator magnets.</li></ul>
Electric clutch not working (Tri-Circuit Alternator)	<ul style="list-style-type: none"><li>• Inline fuse "blown" (if equipped).</li><li>• Loose or corroded wires.</li><li>• Open, shorted or grounded wires between output connector and electric clutch.</li><li>• Defective diode (open or shorted - red output lead side).</li></ul> <p><b>NOTE: Battery will also not charge.</b></p> <ul style="list-style-type: none"><li>• Defective electric clutch switch.</li><li>• Open, shorted or grounded clutch circuit.</li><li>• Low magnetic flux or damaged alternator magnets.</li></ul>

## Charging System Identification

Table No. 1 provides a means of identifying the various alternator systems.

The alternator systems installed on Briggs & Stratton OHV V-Twin Cylinder Engines can be identified by the color of the stator output wires and the connector.

**TABLE 1**

Alternator Type	Stator Output Wire(s) Color	Connector Color	Alternator Output (at 3600 RPM)	Test Page
AC Only	Black	White	5 Amps AC (Lights) Unregulated	35
DC Only	Red	Red	2-4 Amps + DC (Charging) Unregulated	36
Dual Circuit	Red Black	White	2-4 Amps + DC (Charging) Unregulated 5 Amps AC (Lights) Unregulated	37
Tri-Circuit	Black	Green	5 Amps + DC (Charging) 5 Amps – DC (Lights)	38
Regulated 5 Amp	Black	Green	* 1-5 Amps + DC (Charging) Regulated	40
Regulated 9 Amp	Black	Green	* 1-9 Amps + DC (Charging) Regulated	40
Regulated 10 Amp	2-Black	Yellow	* 1-10 Amps + DC (Charging) Regulated	41
Regulated 16 Amp	2-Black	Yellow	* 1-16 Amps + DC (Charging) Regulated	41
Regulated 20 Amp	2-Yellow	White	* 1-20 Amps + DC (Charging) Regulated	43

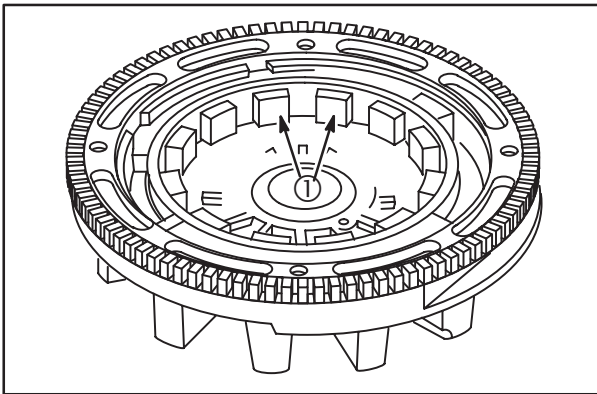
\* Alternator output is determined by flywheel alternator magnet size.

## Flywheel Magnet Identification

**NOTE:** Does NOT include engines with the Power-Link™ system.

The V-Twin flywheels have a ring of magnets (1) on the inside of the flywheel, **Fig. 7**, that provides the magnetic field for the charging systems. The size of the magnet determines the alternator output.

**NOTE:** Flywheels are NOT interchangeable. Use **ONLY** correct flywheel for the application.



**Fig. 7**

Table 2 identifies the magnet size used with the different charging systems.

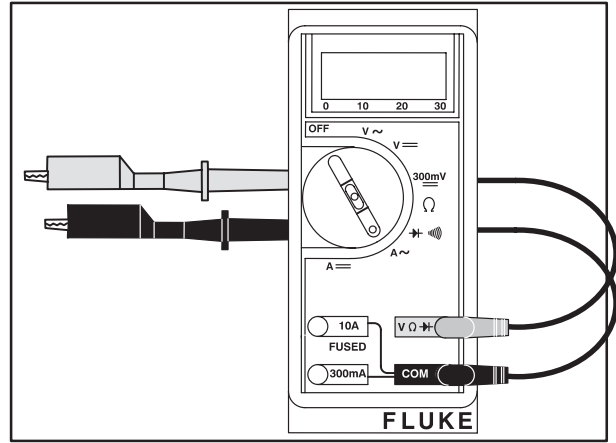
**TABLE 2**

Alternator	Small Magnet	Large Magnet	20A Fly-wheel
<b>Magnet Size</b>	7/8 X 21/32" (22 X 17 mm)	7/8 X 29/32" (22 X 23 mm)	1-3/32 X 29/32" (27 X 23mm)
AC Only	•		
DC Only	•		
Dual Circuit	•		
Tri-Circuit	•		
Regulated 5 A	•		
Regulated 9 A		•	
Regulated 10 A	•		
Regulated 16 A		•	
Regulated 20 A			•

## Equipment Used to Test Alternators

### Digital Multimeter

The Digital Multimeter #19464, **Fig. 8**, is available from your Briggs & Stratton source of supply. The Digital Multimeter can be used to read volts, ohms, amperes, and to test diodes.

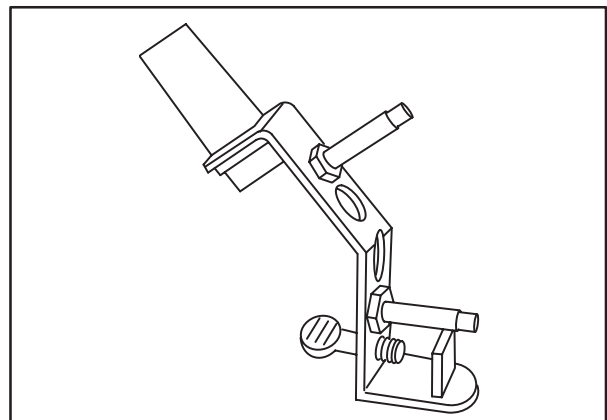


**Fig. 8**

### DC Shunt

The Digital Multimeter will withstand DC input of **10 - 20 amps** for up to **30 seconds**. When checking DC output on 16 and 20 amp regulated systems, use the DC Shunt #19359, **Fig. 9**, to avoid blowing a fuse in the Multimeter.

**NOTE:** The Digital Multimeter is equipped with two fuses to prevent damage to the meter if the input limits of the meter are exceeded. Check the fuses if the meter displays a reading of **0.00** when testing DC output (V=). Refer to the FLUKE Operators Manual for this procedure. Replacement fuses, Part # **19449**, are available from your Briggs & Stratton source of supply.




**Fig. 9**

## Testing Alternator Output

When testing alternators, perform the tests in the following sequence.

**NOTE:** Before testing alternator output, use an accurate tachometer to temporarily adjust the engine speed to the RPM specified in the test instructions.

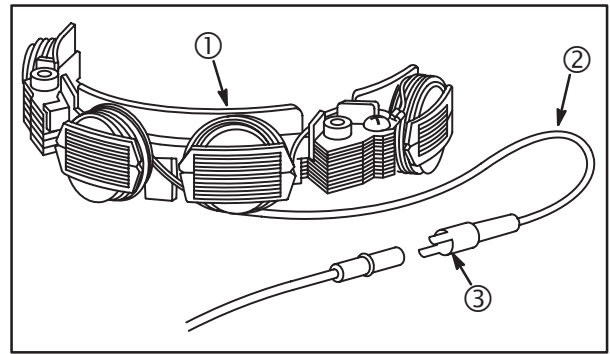
1. Test alternator output.
2. Test diode(s) or regulator-rectifier (if equipped).

	<p><b>WARNING</b></p> <p><b>AVOID INJURY!</b> Engine may exceed safe operating speed, causing personal injury.</p>
<ul style="list-style-type: none"><li>• UPON COMPLETION OF THE ALTERNATOR OUTPUT TEST, READJUST THE ENGINE TO THE CORRECT TOP NO-LOAD GOVERNED SPEED!</li><li>• Correct speed is found in the Service Engine Sales Manual Microfiche, MS-6225 or the Service Sales Manual, MS-4052.</li></ul>	

### AC Alternator

The AC alternator provides current for headlights only. Current for the lights is available when the engine is running. To check, use **12 volt** lights with a total rating of **60 – 100 watts**. Alternator output varies with engine speed. With lights rated at **70 watts**, the voltage rises from **8 volts @ 2400 RPM** to **12 volts @ 3600 RPM**. The lights should become brighter as the engine speed increases.

1. Stator assembly (1), **Fig. 10**, is 5 amps or 14 volts AC for lighting circuit.
2. One BLACK lead from stator (2).
3. WHITE connector output lead (3).

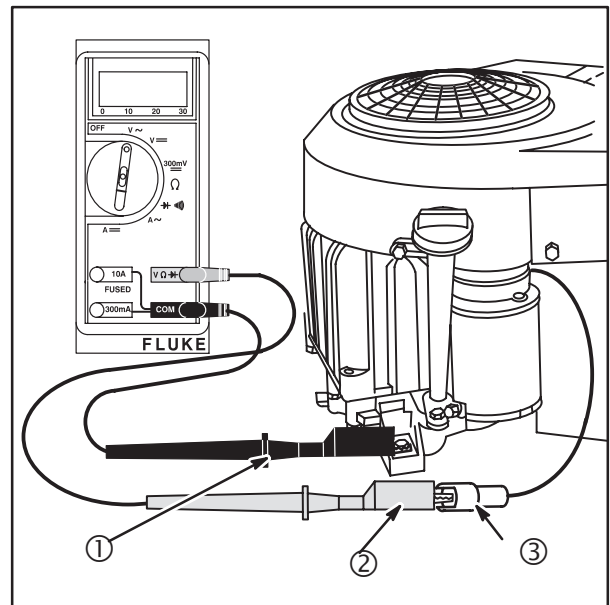


**Fig. 10**

### Output Test

1. Insert RED test lead (2) into **VΩ** receptacle in meter.
2. Insert BLACK test lead (1) into **COM** receptacle.
3. Rotate selector to **V~** (AC VOLTS) position.
4. Attach RED test lead clip to AC output terminal (3), **Fig. 11**.
5. Attach BLACK test lead clip to engine ground.
6. With engine running at **3600 RPM**, AC output should be no less than **14 volts**.

If **NO** or **LOW** output is found, replace the stator.



**Fig. 11**

## DC Alternator

The DC alternator provides DC current for charging a 12 volt battery. The current from the alternator is unregulated and is rated at **3 amps**. The output rises from **2 amps @ 2400 RPM**, to **3 amps @ 3600 RPM**.

1. Stator assembly (1), Fig. 12.
2. One RED lead from stator (2).
3. DIODE encased at connector (3).
4. RED connector output lead (4).

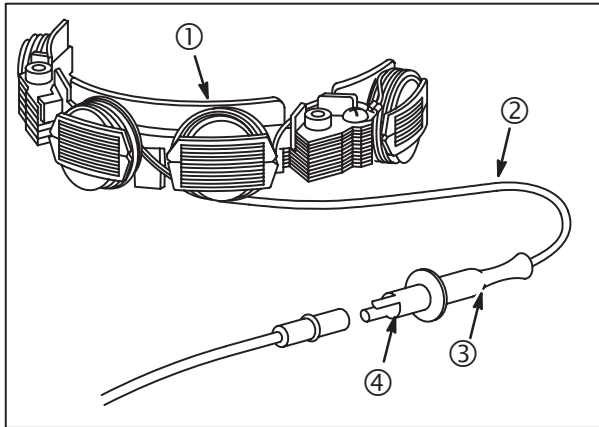


Fig. 12

### Output Test

**NOTE:** The battery MUST be in good condition to perform this test.

WHEN CHECKING ALTERNATOR COMPONENTS, PERFORM THE TEST IN THE FOLLOWING SEQUENCE:

1. Insert RED test lead into **10A** receptacle in meter.
2. Insert BLACK test lead into **COM** receptacle.
3. Rotate selector to **A==** (DC amps) position.
4. Attach RED test lead clip (1) to DC output terminal, Fig. 13.
5. Attach BLACK test lead clip to POSITIVE (+) battery terminal (2).
6. With engine running at **3600 RPM**, output should be **2 - 4 amps DC**.

**NOTE:** The output will vary with the battery voltage. If the battery is at maximum voltage the output will be approximately 2 amps.

7. If **NO** or **LOW** output is found, test diode.

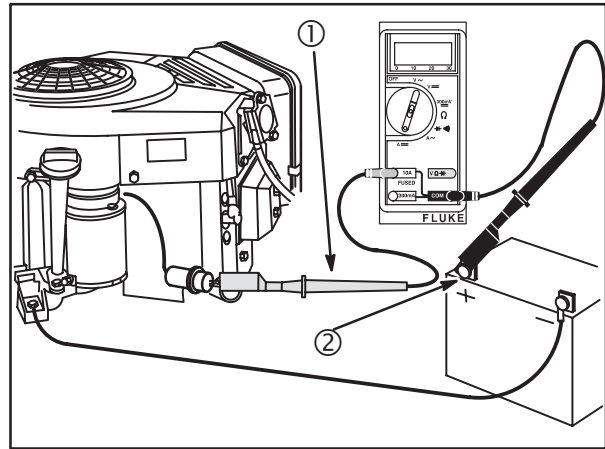


Fig. 13

### Diode Test

In the DIODE TEST position, the meter will display the forward voltage drop across the diode(s). If the voltage drop is **less than 0.7 volts**, the meter will BEEP once and display the voltage drop. A **CONTINUOUS TONE** indicates CONTINUITY (shorted diode). An INCOMPLETE CIRCUIT (open diode) is displayed as **OL**.

1. Insert RED test lead (1) into **VΩ** receptacle in meter.
2. Insert BLACK test lead (2) into **COM** receptacle in meter.
3. Rotate selector to **+)))** (DIODE TEST) position.
4. Attach RED test lead clip to point A and BLACK test lead clip to the stator output lead (3), Fig. 14. (It may be necessary to pierce the wire with a pin as shown.)
  - a. If meter **BEEPS once**, diode is OK.
  - b. If meter makes a **CONTINUOUS TONE**, diode is defective (shorted). Replace diode.
  - c. If meter displays **OL** proceed to step 5.
5. Reverse test leads.
  - a. If meter **BEEPS once**, diode is installed backwards. Replace diode.
  - b. If meter still displays **OL**, diode is open. Replace diode.
6. If diode tests OK, check stator for bare wires or other obvious defects. If bad or grounded leads are not visible, replace the stator.

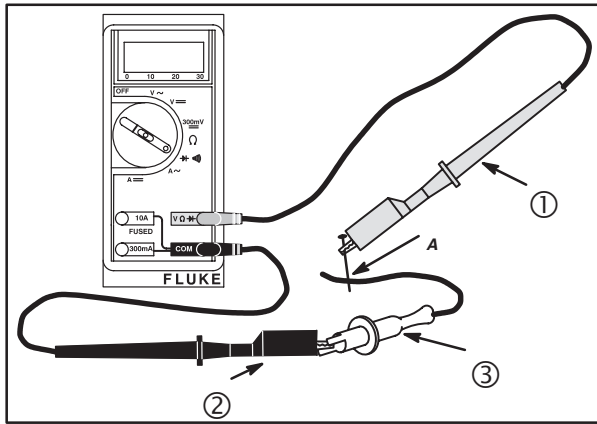


Fig. 14

**NOTE:** Service replacement diode harnesses are available. Use resin core solder when installing new harness. Use shrink tubing or tape all connections.  
DO NOT USE CRIMP CONNECTORS.

### Dual Circuit Alternator

Dual circuit alternators use a polarized plug with two pins. One pin provides DC current for charging the battery, the second pin is an independent AC circuit for headlights.

Current for lights is available when the engine is running. The output varies with engine speed, so brightness of the lights changes with engine speed. **12 volt** lights with a total rating of **60 to 100 watts** may be used. With lights rated at **70 watts**, the voltage rises from **8 volts @ 2400 RPM** to **12 volts at 3600 RPM**. Since the battery is not used for the lights, the lights are available even if the battery is disconnected or removed.

Current from the DC side of the alternator is unregulated and is rated at **3 amps**. The output rises from **2 amps @ 2400 RPM** to **3 amps @ 3600 RPM**.

1. Stator assembly (1), Fig. 15.
2. RED lead from stator (2), DC output for charging battery.
3. BLACK lead from stator (3), AC output for lighting circuit.
4. DIODE encased at connector (4).
5. WHITE lead (5) for AC lighting circuit.
6. RED lead (6) for DC charging circuit.

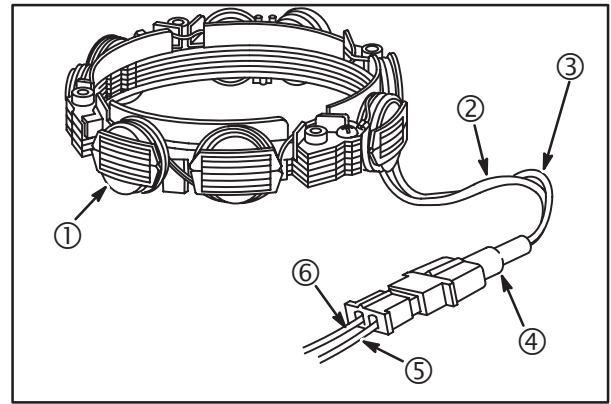


Fig. 15

### DC Output Test

**NOTE:** The battery **MUST** be in good condition to perform this test.

1. Insert RED test lead into **10A** receptacle in meter.
2. Insert BLACK test lead into **COM** receptacle in meter.
3. Rotate selector to **A==** (DC AMPS) position.
4. Attach RED test lead clip (1) to DC output pin (6) in connector (4), Fig. 16.

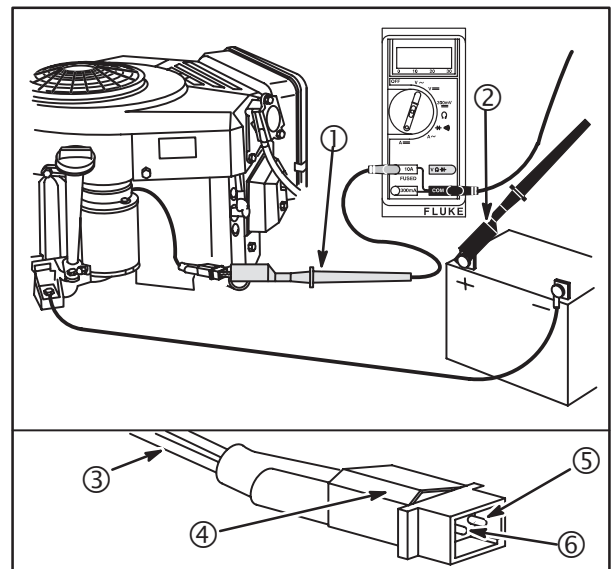


Fig. 16

**NOTE:** The raised rib on the connector or the RED wire (3) indicates the DC output pin side. The AC pin (5) is not used for this test.

5. Attach BLACK test lead clip (2) to POSITIVE (+) battery terminal.
6. With engine running at **3600 RPM** output should be between **2 - 4 amps DC**.

**NOTE:** The output will vary with the battery voltage. At maximum battery voltage the output will be approximately 2 amps.

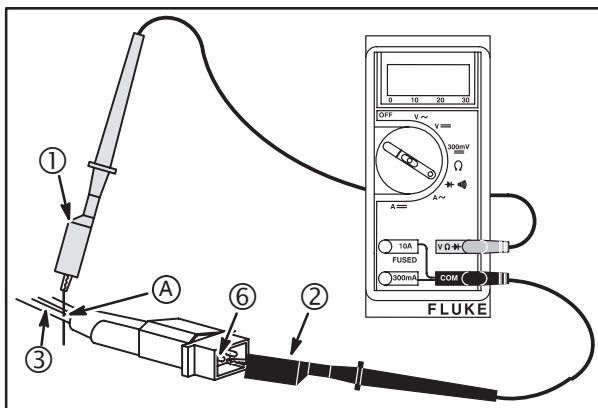
7. If **NO** or **LOW** output is found, test diode.

## Diode Test

In the DIODE TEST position, the meter will display the forward voltage drop across the diode(s). If the voltage drop is less than **0.7 volts**, the meter will **BEEP** once and display the voltage drop. A **CONTINUOUS TONE** indicates **CONTINUITY** (shorted diode) An **INCOMPLETE CIRCUIT** (open diode) will be displayed as **OL**.

1. Insert RED test lead into **VΩ** receptacle in meter.
2. Insert BLACK test lead into **COM** receptacle in meter.
3. Rotate selector to **+)))))** (DIODE TEST) position.
4. Attach RED test lead clip (1) to point A and BLACK test lead clip (2) to DC output pin (6), **Fig. 17**. (It may be necessary to pierce wire with a pin as shown.)
  - a. If meter **BEEPS** once, diode is OK.
  - b. If meter makes a **CONTINUOUS TONE**, diode is shorted. Replace diode.
  - c. If meter displays **OL**, proceed to step 5.
5. Reverse test leads.
  - a. If meter **BEEPS** once, diode is installed backwards. Replace diode.
  - b. If meter still displays **OL**, diode is open. Replace diode.
6. If diode tests OK, check stator for bare wires or other obvious defects. If grounded leads are not visible, replace the stator.

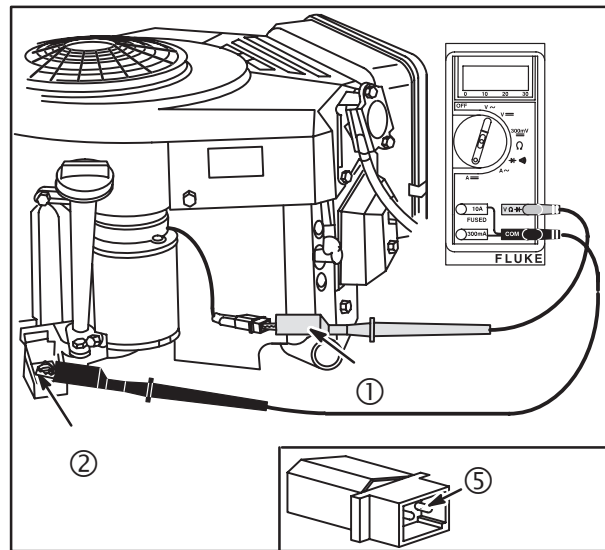
**NOTE:** Service replacement diode harnesses are available. Use resin core solder when installing new harness. Use shrink tubing or tape all connections. **DO NOT USE CRIMP CONNECTORS.**



**Fig. 17**

## AC Output Test

1. Insert RED test lead into **VΩ** receptacle in meter.
2. Insert BLACK test lead into **COM** receptacle.
3. Rotate selector to **V~** (AC VOLTS) position.
4. Attach RED test lead clip (1) to AC output terminal (5), **Fig. 18**.
5. Attach BLACK test lead clip (2) to engine ground.
6. With engine running at 3600 RPM output should be no less than **14 volts AC**.
7. If **NO** or **LOW** output is found, replace stator.



**Fig. 18**

## Tri-Circuit Alternator

The tri-circuit alternator provides alternating current (AC) through a single output lead and connector to a wiring harness containing two diodes.

One diode rectifies the AC current to 5 amps **NEGATIVE (-)** DC for lights. The second diode rectifies the AC current to 5 amps **POSITIVE (+)** DC for battery charging and external loads, such as an electric clutch.

**NOTE:** Some original equipment manufacturers (OEMs) supply diodes as an integral part of the equipment wiring harness. Some OEMs use a 1 Ohm-20 Watt resistor placed in series with (+) DC charging lead, limiting the charging current to approximately 3 amps when the clutch is not engaged. When the clutch is engaged the resistor is bypassed allowing full output to the battery and clutch.

The battery is not used for the lights, so lights are available even if the battery is disconnected or removed. Current for the lights is available when the engine is running. The output varies with engine RPM, so the brightness of the lights changes with engine speed.

Stator assembly (1), **Fig. 19**.

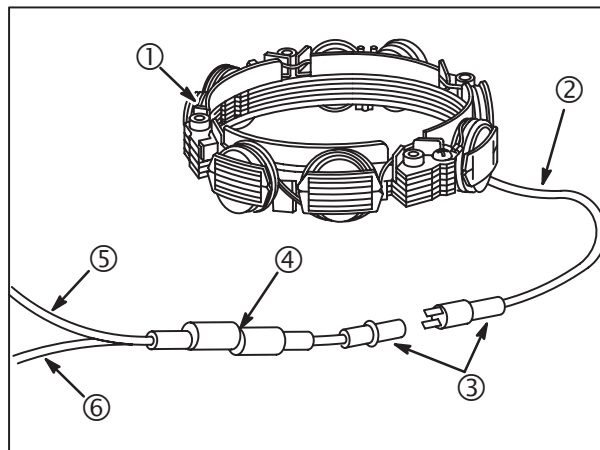
BLACK lead from stator (2).

Connector (3).

Two diodes encased in wiring harness (4).

WHITE lead – 5 amps DC (-) to lights (5).

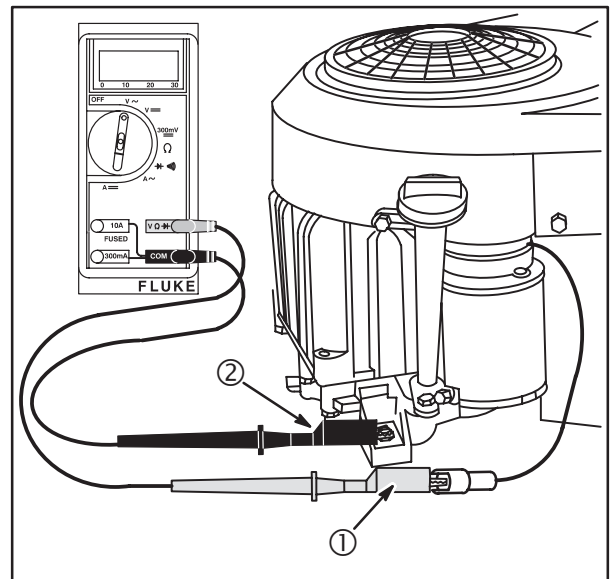
RED lead – 5 amps DC (+) to battery, clutch (6).



**Fig. 19**

### **Output Test**

1. Insert RED test lead into **VΩ** receptacle in meter.
2. Insert BLACK test lead into **COM** receptacle.
3. Rotate selector to **V~** (AC VOLTS) position.
4. Attach RED test lead clip (1) to output terminal (GREEN connector), **20**.
5. Attach BLACK test lead clip (2) to engine ground.
6. With engine running at **3600 RPM**, output should be no less than **28 VOLTS AC**.
7. If **NO** output or **LOW** output is found, replace stator.
8. If alternator output is good, test the diodes in the wiring harness.



**Fig. 20**

### **Diode Test**

**NOTE:** One diode is for the charging circuit, the other diode is for the lighting circuit.

In the **DIODE TEST** position, the meter will display the forward voltage drop across the diode(s). If the voltage drop is less than **0.7 volts**, the meter will BEEP once as well as display the voltage drop. A **CONTINUOUS TONE** indicates **CONTINUITY** (shorted diode). An **INCOMPLETE CIRCUIT** (open diode) will be displayed as **OL**.

### **Charging Circuit Test (RED Wire)**

1. Insert RED test lead into **VΩ** receptacle in meter.
2. Insert BLACK test lead into **COM** receptacle in meter.
3. Rotate selector to **+)))))** (**DIODE TEST**) position.
4. Attach BLACK test lead clip (2) to point A of the RED wire (3), **Fig. 21**. (It may be necessary to pierce wire with a pin as shown.)
5. Insert RED test lead (1) into harness connector.
  - a. If meter BEEPS once, diode is OK.
  - b. If meter makes a **CONTINUOUS TONE**, diode is shorted. Replace harness.
  - c. If meter displays **OL** proceed to step 6.
6. Reverse test leads.
  - a. If meter **BEEPS ONCE**, diode is installed backwards. Replace harness.
  - b. If meter still displays **OL**, diode is open. Replace harness.



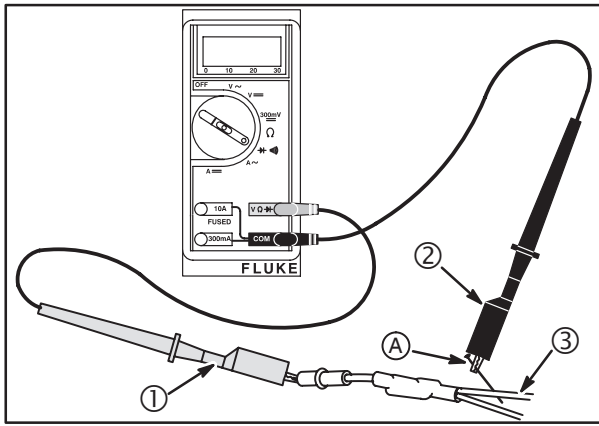


Fig. 21

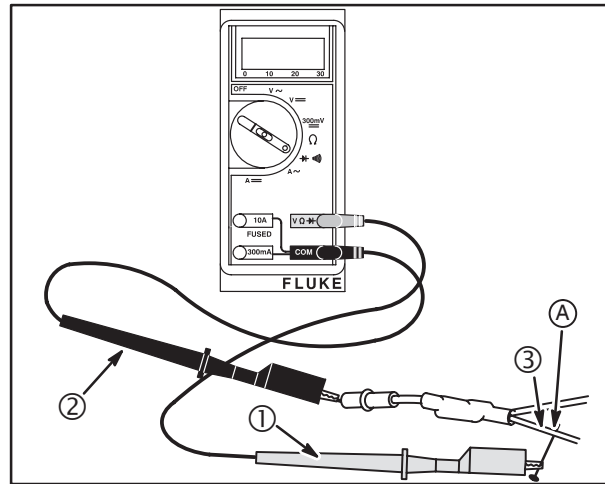


Fig. 22

### Lighting Circuit Test (WHITE Wire)

1. Insert RED test lead into **VΩ** receptacle in meter.
2. Insert BLACK test lead into **COM** receptacle.
3. Rotate selector to **+)))** (DIODE TEST) position.
4. Attach RED test lead clip (1) to point A, of the WHITE wire (3) **Fig. 22**. (It may be necessary to pierce wire with a pin as shown.)
5. Insert BLACK test lead probe (2) into harness connector.
  - a. If meter **BEEPS** once, diode is OK.
  - b. If meter makes a **CONTINUOUS TONE**, diode is shorted. Replace harness.
  - c. If meter displays **OL** proceed to step 6.
6. Reverse test leads.
  - a. If meter **BEEPS** once, diode is installed backwards. Replace harness.
  - b. If meter still displays **OL** diode is open. Replace harness.

**NOTE:** Service replacement diode harnesses are available.

### 5 & 9 Amp Regulated Alternator

The 5 & 9 amp regulated alternator systems provide AC current through a single lead to the regulator-rectifier. The regulator-rectifier converts the AC current to DC and regulates current to the battery. The charging rate will vary with engine RPM and temperature.

Alternator output is determined by the flywheel alternator magnet size. The stator and regulator-rectifier are the same for the 5 & 9 amp regulated system and the Tri-Circuit system.

Stator assembly (1), **Fig. 23**.

BLACK lead (2).

GREEN connector (3).

YELLOW wire (4).

RED connector (5).

Regulator-rectifier (6).

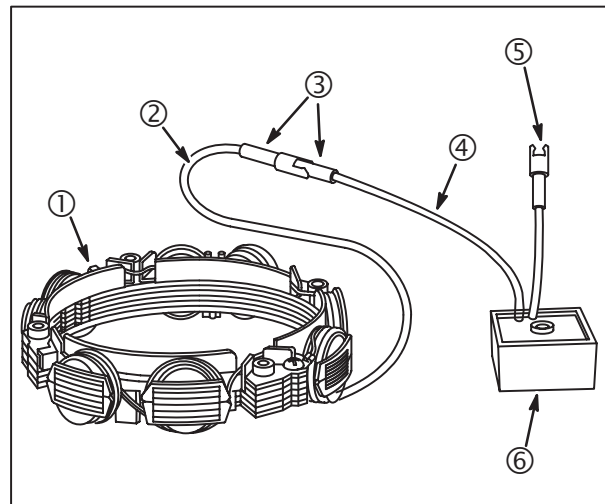


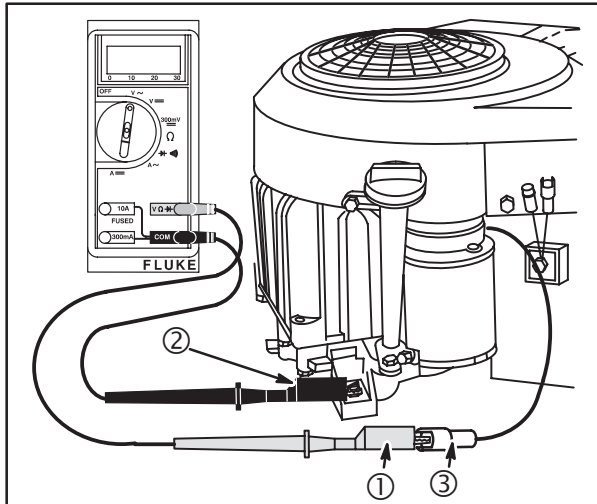
Fig. 23

## Output Test

WHEN CHECKING ALTERNATOR COMPONENTS MAKE TESTS IN THE FOLLOWING SEQUENCE:

Temporarily disconnect stator wire harness from regulator-rectifier.

1. Insert RED test lead into **VΩ** receptacle in meter.
2. Insert BLACK test lead into **COM** receptacle.
3. Rotate selector to **V~** (AC VOLTS) position.
4. Attach RED test lead clip (1) to GREEN output terminal (3), **Fig. 24**.
5. Attach BLACK test lead clip (2) to engine ground.
6. With the engine running at **3600 RPM**, AC output should be **no less than**:
  - **28 Volts AC – 5 Amp System**
  - **40 Volts AC – 9 Amp System**
7. If **NO** or **LOW** output is found, replace the stator.



**Fig. 24**

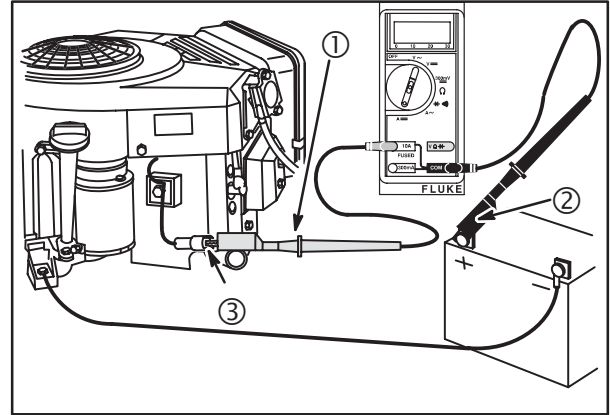
## Regulator-Rectifier Test

**NOTE:** The regulator-rectifier will not function unless it is grounded to engine. Make sure the regulator-rectifier is securely mounted to the engine. When testing regulator-rectifier for amperage output, a 12 volt battery with a minimum charge of 5 volts is required. There will be no output if battery voltage is below 5 volts.

**CAUTION:** Connect test leads **BEFORE** starting engine. Be sure connections are secure. If a test lead vibrates loose while engine is running, the regulator-rectifier may be damaged.

Connect stator wire harness to regulator-rectifier.

1. Insert RED test lead into **10A** receptacle in meter.
2. Insert BLACK test lead into **COM** receptacle.
3. Rotate selector to **A==** (DC AMPS) position.
4. Attach RED test lead clip (1) to RED DC output terminal (3) on regulator-rectifier, **Fig. 25**.



**Fig. 25**

5. Attach BLACK test lead clip (2) to POSITIVE (+) battery terminal.
6. Run the engine at **3600 RPM**. The output should be:
  - **3-5 Amps – 5 Amp System**
  - **3-9 Amps – 9 Amp System**

**NOTE:** The amperage produced depends on battery voltage. If the battery is below **11 volts**, the output reading would be **5 or 9 amps**, depending upon the alternator system being tested. The amperage will be less at maximum battery voltage.

7. If **NO** or **LOW** output is found, be sure that regulator-rectifier is grounded properly and all connections are clean and secure. If there is still **NO** or **LOW** output, replace the regulator-rectifier.

## 10 & 16 Amp Regulated Alternator

The 10 or 16 amp regulated alternator system provides AC current through two **YELLOW** output leads to the regulator-rectifier. The regulator-rectifier converts the AC current to DC and regulates current to the battery. The charging rate varies with engine RPM and temperature.

The stator and regulator-rectifier are the same for the 10 and 16 amp systems. The system output is determined by the flywheel magnet size.

1. Stator Assembly (1) – 10 or 16 amp DC regulated system, **Fig. 26**.

2. Two BLACK leads (2) from stator.
3. YELLOW connector (3) with two pin terminals.
4. Two YELLOW leads (4) to regulator-rectifier.
5. Regulator-rectifier (5).
6. One RED lead from regulator-rectifier to RED connector output lead (6).

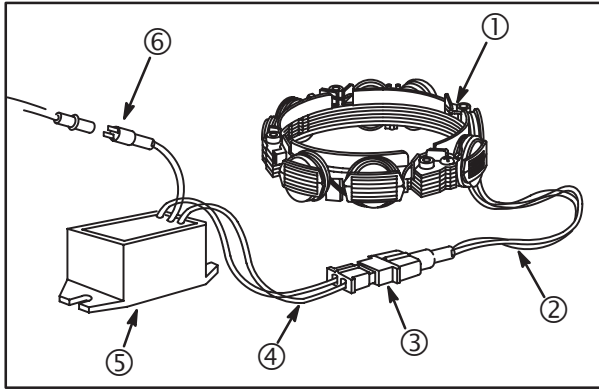


Fig. 26

### Output Test

Temporarily, disconnect stator wire harness from regulator-rectifier.

1. Insert RED test lead into **VΩ** receptacle in meter.
2. Insert BLACK test lead into **COM** receptacle.
3. Rotate selector to **V~** (AC VOLTS) position.
4. Insert RED (1) and BLACK (2) test lead probes into output terminals (4, 5) in YELLOW connector (3), as shown in **Fig. 27**. (Test clip leads may be attached to either terminal.)

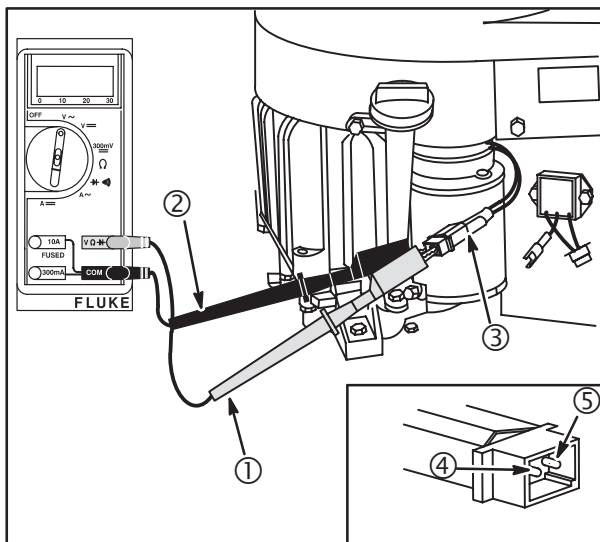


Fig. 27

5. With the engine running at **3600 RPM** output should be no less than:

- **20 Volts – 10 Amp System**
- **30 Volts – 16 Amp System**

6. If **NO** or **LOW** output is found check for bare wires or other defects. If wiring defects are not visible, replace the stator.

### Regulator-Rectifier Test

**NOTE:** Make sure the regulator-rectifier is securely mounted to engine. Regulator-rectifier will not function unless it is grounded to engine. When testing regulator-rectifier for amperage output, a 12 volt battery with a minimum charge of 5 volts is required. There will be no output if battery voltage is below 5 volts.

**CAUTION:** Connect test leads **BEFORE** starting engine. Be sure connections are secure. If a test lead vibrates loose while engine is running, the regulator-rectifier could be damaged.

Use the DC Shunt #**19359** (4) to avoid blowing the fuse in the test meter when testing the DC output of the 16 amp system.

The DC shunt **MUST** be installed to the **NEGATIVE (-)** terminal of the battery, **Fig. 28**. All connections must be clean and tight to obtain accurate readings.

1. Connect stator wire harness to regulator-rectifier.
2. Install shunt to negative battery terminal.
3. Insert RED test lead (1) into **VΩ** receptacle in meter. Connect to RED post terminal (3) on shunt, **Fig. 28**.
4. Insert BLACK test lead (2) into **COM** receptacle in meter and connect to BLACK post terminal (5) on shunt.
5. Rotate selector to **300mV** position.
6. With the engine running at **3600 RPM**, the output should be:

- **3-10 Amps – 10 Amp System**
- **3-16 Amps – 16 Amp System**

**NOTE:** The amperage produced depends on battery voltage. If the battery is below 11 volts, the output would be **10 or 16 amps** depending on the alternator system being tested. The amperage will be less at maximum battery voltage.

- If **NO** or **LOW** output is found, be sure that regulator-rectifier is grounded properly and all connections are clean and secure. If there is still **NO** or **LOW** output, replace the regulator-rectifier.

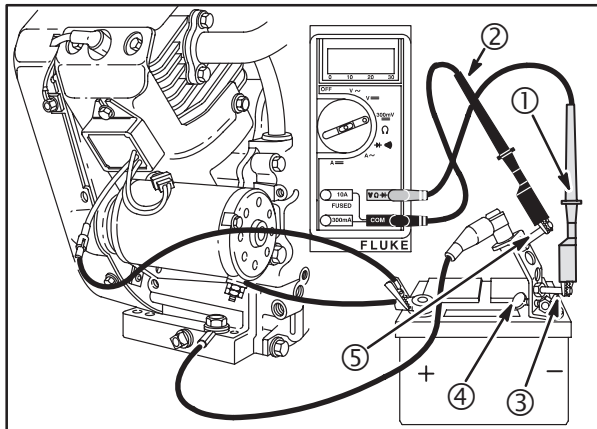


Fig. 28

### Regulator-Rectifier With Charge Indicator

Regulator-rectifier Part #493219, Fig. 29, is used by OEMs that have a charging indicator light instead of an ammeter. In addition to the RED DC output wire (1), the regulator-rectifier has a BLUE wire (2), to activate a charging indicator light when battery voltage is below 12 volts. The connector has a raised rib (3) on the RED wire side to indicate the output side of the connector.

The charging indicator light should light when the key switch is ON and the engine not running. With engine running, the charging indicator light should go out, indicating that the charging circuit is operating and the battery voltage is above **12 volts**.

The charge indicator light and wiring is supplied by the OEM. See typical wiring diagram.

DC charging output values and test procedures are the same as those listed for the 10 amp or 16 amp system.

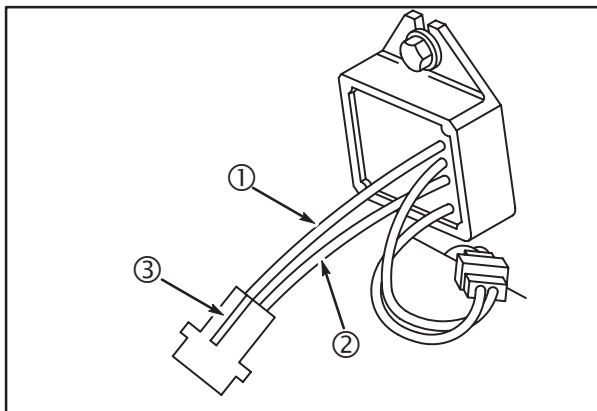


Fig. 29

### 20 Amp Regulated Alternator

The 20 amp regulated alternator system provides AC current through two output leads to the regulator-rectifier. The regulator-rectifier converts the AC current to DC, and regulates current to the battery. The charging rate will vary with engine RPM and temperature.

- Stator assembly (1), Fig. 30.
- Two YELLOW leads (2) from stator.
- RED DC output lead (3) from connector.
- Connector (4).
- Two YELLOW AC input leads (5).
- Regulator-rectifier (6).
- RED DC output lead (7) to connector

**NOTE:** Stator (1), regulator-rectifier (6) and fly-wheel are **NOT INTERCHANGEABLE** with any other charging system.

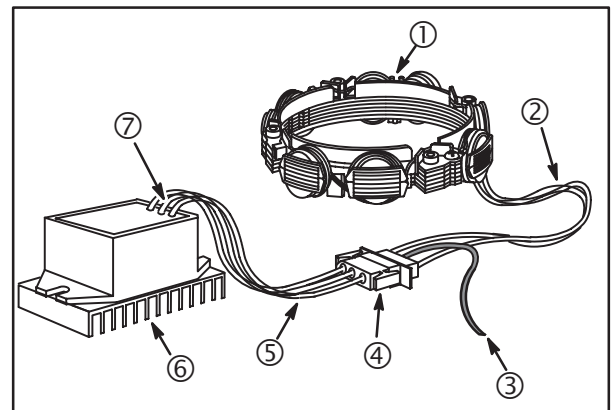


Fig. 30

### Output Test

WHEN CHECKING THE ALTERNATOR COMPONENTS, PERFORM THE TESTS IN THE FOLLOWING SEQUENCE:

Temporarily disconnect stator wire harness from regulator-rectifier.

- Insert RED test lead into **VΩ** receptacle in meter.
- Insert BLACK test lead into **COM** receptacle.
- Rotate selector to **V~ (AC VOLTS)** position.

**CAUTION:** Attach meter test leads to the AC output terminals (YELLOW wires) in the connector **BEFORE** starting the engine. If the stator is grounded (defective) and the meter test leads contact the center DC output pin (RED wire) in the connector, arcing could occur, damaging the wiring.

- Attach RED (2) and BLACK (1) test lead probes to the YELLOW wire (4) AC output terminals (6), of the connector (3), as shown in **Fig. 31**. (Meter test clip leads may be attached to either AC output terminal.)
- If **NO** or **LOW** output is found check for bare wires or other defects. If shorted leads are not visible, replace the stator.
- With the engine running at **3600 RPM** output should be **no less than 26 Volts**.

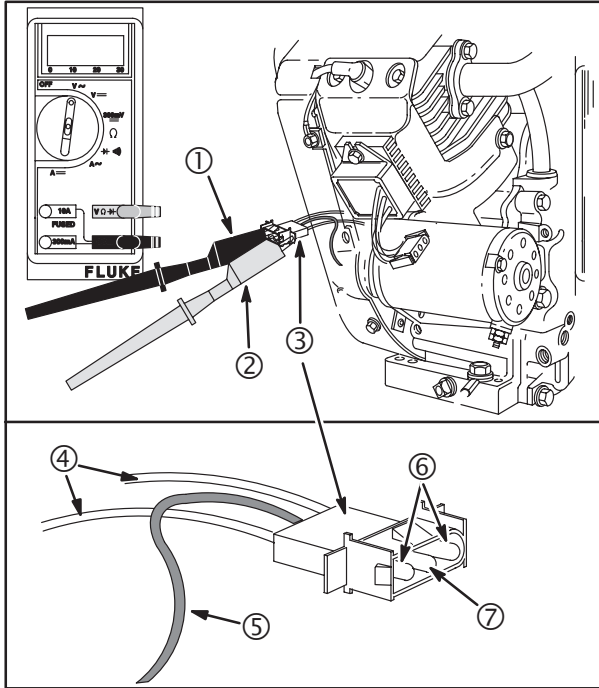


Fig. 31

### DC Output Charging Wire Test

A simple test can be used to test the DC output charging wire circuit. If a wiring problem exists it can be corrected before testing regulator-rectifier.

Leave stator wire harness disconnected from regulator-rectifier.

Equipment key switch must be in OFF position.

- Insert RED test lead into VΩ receptacle in meter.
- Insert BLACK test lead into **COM** receptacle.
- Rotate selector to **V==** (DC volts) position.
- Attach RED test lead probe (2) to the RED wire (5) DC output terminal (7), of the connector, **Fig. 31**.
- Attach BLACK test lead probe (1) to negative battery terminal.
- Turn equipment key switch to ON position. Meter should display **BATTERY VOLTAGE**.

- If meter does not display battery voltage, check for blown fuse or broken or shorted wires.

### Regulator-Rectifier Test

#### Tools Required:

DC Shunt #19359

The DC Shunt **must** be installed on the NEGATIVE (-) terminal of the battery, **Fig. 32** to avoid blowing the fuse in the meter when testing the output of the 20 amp system. All connections must be clean and tight for correct readings.

- Connect stator wire harness to regulator-rectifier.
- Install DC shunt #19359 (4) on NEGATIVE battery terminal.
- Insert RED test lead into VΩ receptacle in meter and connect to RED post terminal on shunt (5), **Fig. 32**.
- Insert BLACK test lead into **COM** receptacle in meter. Connect to BLACK post terminal on shunt (3).
- Rotate selector to **300mV** position.
- With the engine running at **3600 RPM**, the output should be **3-20 Amps**.

**NOTE:** Depending upon battery voltage and/or current draw on system.

If **NO** or **LOW** output is found, be sure that regulator-rectifier is grounded properly and all equipment connections are clean and secure. If there is still **NO** or **LOW** output, replace the regulator-rectifier.

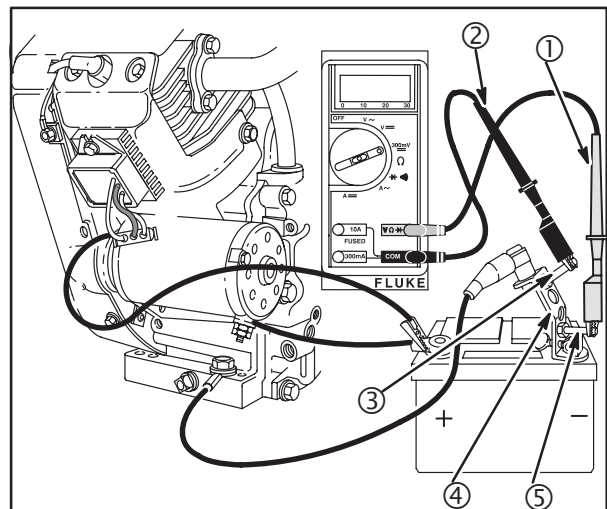


Fig. 32

## POWERLINK™ SYSTEM

Some V-Twin engines are equipped with the PowerLink™ System, an on-board generator system for riding tractors that provides 120 volt, 60 cycle AC to a GFCI receptacle provided by the OEM.

The PowerLink™ system will not function unless the parking brake on the tractor is ENGAGED (1), **Fig. 52**, and the PTO on the tractor is OFF. The PowerLink™ system will shut down if there is a system or temperature overload, or if there is a ground fault.

### Resetting PowerLink™ System

**NOTE:** Turn OFF or unplug any device or appliance that was connected to the PowerLink™ System. Verify that the reset button on the GFCI has not been tripped.

1. The engine must be running with the parking brake set and the PTO DISENGAGED.
2. Actuate the PowerLink™ reset switch. Move the reset switch to the OFF position, then return it to the ON position. For operator safety there is a two second delay in power to the GFCI receptacle after reset.



**Fig. 33**

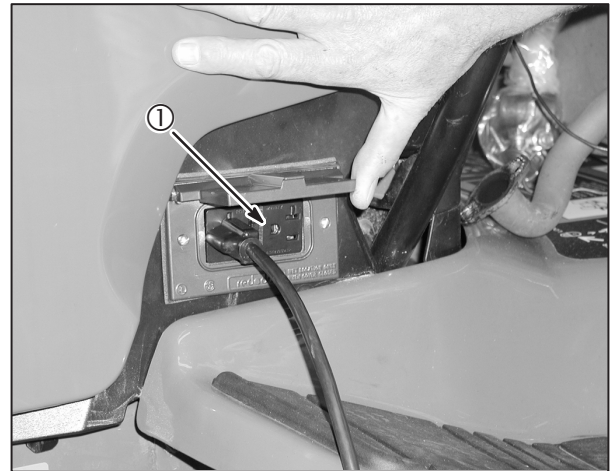
### Testing the GFCI

1. The engine must be running with the parking brake (1) set and the PTO DISENGAGED.
2. Plug in a trouble light or radio to confirm that electrical power is present.
3. Press the GFCI test button (1) to trip the GFCI, **Fig. 34**.

If the device is still being powered the GFCI is NOT working correctly. Replace the GFCI.

4. If the power goes OFF the GFCI is working correctly. Press the reset button to restore power.

**NOTE:** Use only OEM approved GFCI components.



**Fig. 34**

### Test PowerLink™ System

If a problem occurs and the PowerLink™ system is suspect, follow the test procedure in exactly the order shown to isolate the faulty component.

#### Required tools:

- Digital Multimeter, Tool #19464
- PowerLink™ Test Box, Tool #19528

1. Test the GFCI (previous procedure).
2. Test the parking brake interlock switch.
3. Test the PowerLink™ reset (ON-OFF) switch on the tractor.
4. Check alternator output.

### Test PowerLink™ System Ground Continuity

Digital Multimeter #19464 is used to test the ground circuits.

With the meter in the +))) (DIODE TEST) position, and the test leads attached to the grounds, a **CONTINUOUS TONE** indicates CONTINUITY (complete circuit). **NO TONE** indicates NO CONTINUITY (open circuit). Open circuits are displayed as **OL**.

1. Insert RED test lead into **VΩ** receptacle in meter.
2. Insert BLACK test lead into **COM** receptacle.
3. Test for continuity between the inverter case and the engine frame, **Fig. 35**.

- Test for continuity between the inverter case and the GFCI ground.

There should be **CONTINUITY** in Step 3 and Step 4. If there is **NO CONTINUITY** a problem exists in the ground circuit.



Fig. 35

### Test Parking Brake Interlock Switch

Digital Multimeter #19464 is used for this test.

Set the meter in to the DC VOLTS position.

- Place the key switch in the OFF position. Lock the parking brake and ensure the PTO is **OFF**.
- Disconnect the interlock switch wire from the RED inverter wire.
- Insert RED meter test lead into the brake interlock switch wire connector (1), **Fig. 36**.
- Attach the BLACK meter test lead to the **NEGATIVE** battery terminal (2).
- Turn the equipment key switch **ON**.

The meter should display **BATTERY VOLTAGE**. If the meter does not display battery voltage there is a problem with the equipment wiring or the interlock switch. Refer to the equipment repair manual.

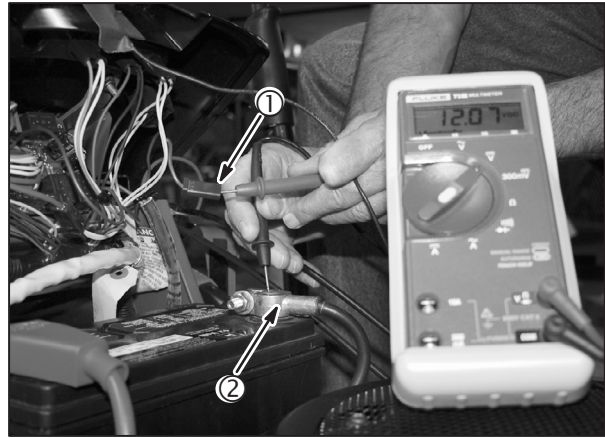


Fig. 36

### Testing PowerLink™ Reset Switch

Digital Multimeter #19464 is used for this test. Set the meter to the +))))) (DIODE TEST) position.

- Remove reset (ON-OFF) switch from equipment. Disconnect from wiring harness.
- Attach one meter test lead to each terminal on the switch, **Fig. 37**. Activate switch.

There should be a **CONTINUOUS TONE** (continuity) with the switch in the **ON** position. There should be **NO TONE** (open circuit) with the switch in the **OFF** position.

Replace the switch if not to specification.

**NOTE:** Use only OEM approved reset switch components.

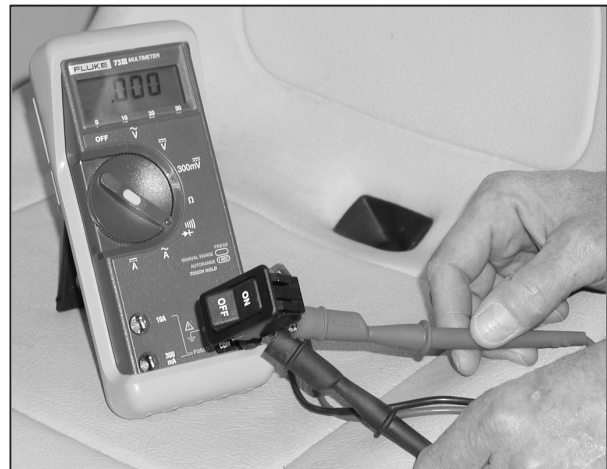


Fig. 37

### Testing PowerLink™ Alternator Output

**NOTE:** It may be necessary to remove the inverter from the equipment.

If the previous tests have not revealed a faulty component it is necessary to check the alternator output. If the alternator output is within specification the inverter box is faulty and must be replaced.

Required tools to test the PowerLink™ system are:

- Digital Multimeter (2), Tool #19464
- PowerLink™ Test Box (1) #19528
- Torx Driver #19445
- Tachometer #19389 or 19200

**CAUTION:** Make all connections BEFORE starting the engine.

1. Use Torx Driver #19445 to remove tamper proof screws and the PowerLink™ harness plug at the inverter.
2. Install alternator harness plug into socket in PowerLink™ Test Box #19528 (1), Fig. 38.

If the alternator output is **LESS THAN 100 Volts**, replace the stator.

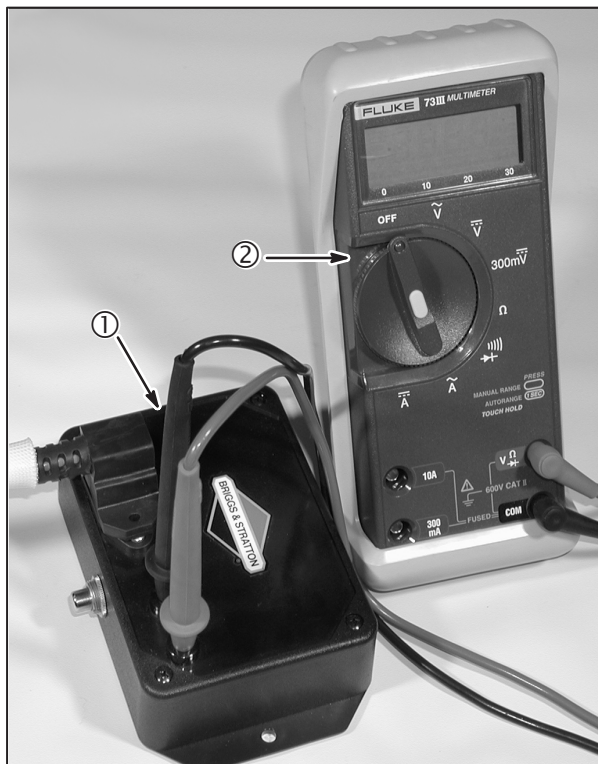


Fig. 38

3. Set Digital Multimeter (2) to read AC Volts.
4. Insert meter test leads into either receptacle in test box.
5. Start engine. Set speed to **1800 RPM**.

**NOTE:** DO NOT exceed **1800 RPM**.

6. Press button on test box and note AC voltage. Alternator output should be **NO LESS THAN 100 Volts**.

If the alternator output is **100 volts or HIGHER**, replace the inverter.

### Anti-Afterfire Solenoid

The anti-afterfire solenoid is controlled by the equipment ignition switch. With the switch **OFF**, the solenoid plunger closes, stopping fuel flow through the fixed main jet. With the switch in the **ON** and **START** positions, the solenoid plunger opens, allowing normal fuel flow. The solenoid is operating properly if it **CLICKS** when the switch is turned **ON** and **OFF**.

If solenoid does not **CLICK**, the problem could be the equipment wiring, engine wiring or the solenoid. To determine which is the problem, perform the following tests in the order shown.

#### Solenoid Test

**NOTE:** The solenoid requires a minimum of 9 volts DC to function.

1. Remove anti-afterfire solenoid from carburetor.
2. Place a jumper wire on either terminal of a 9 volt transistor battery and on one of the pins in the solenoid connector.
3. Place another jumper wire on the remaining pin in the solenoid connector and on the other terminal on the battery, Fig. 33.

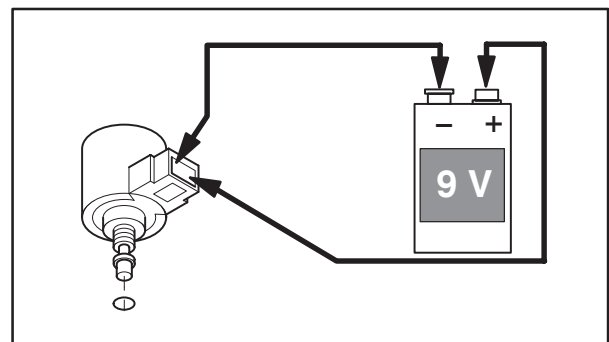


Fig. 39

Plunger should retract freely.

When battery connection is removed, plunger should return.

Replace solenoid if plunger sticks or doesn't move.

**NOTE:** Model 350400 with Mikuni carburetor:  
With 9 volt battery applied to solenoid, apply finger pressure to tip of solenoid. The tip must be retracted manually approximately **0.030" (0.8 mm)** before the solenoid will energize.



## Test Equipment

Digital Multimeter #19464.

The following tests will be performed with the meter in the **V<sub>DC</sub>** (DC volts) position, **Fig. 40**.

2

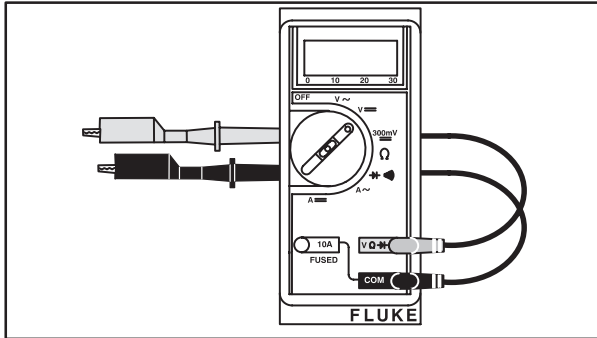


Fig. 40

## Equipment Wiring Test

1. With key switch **OFF**, disconnect equipment wiring harness connector (1) from engine wiring harness.
2. Attach RED meter test lead (2) into equipment wiring harness connector (1) (side opposite raised rib).
3. Attach BLACK test lead to a good ground, **Fig. 41**.
4. Turn key switch **ON**. Meter should display **battery voltage**.

If meter does not display **battery voltage**, the problem is with the equipment wiring harness. If meter displays **battery voltage**, test engine harness.

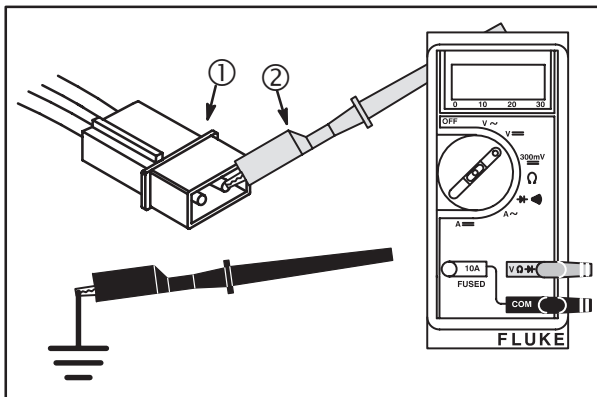


Fig. 41

## Testing Battery

	<b>WARNING</b> Batteries contain ACID which is poisonous and causes severe burns. Avoid contact with skin, eyes or clothing.
<ul style="list-style-type: none"><li>• <b>EXTERNAL CONTACT:</b> Flush with clear water for AT LEAST 20 minutes. Call a Physician IMMEDIATELY.</li><li>• <b>INTERNAL:</b> Drink large quantities of milk or water. Follow with Milk of Magnesia or Vegetable Oil. Call a physician IMMEDIATELY.</li><li>• <b>EYES:</b> Force eye open and flush with clear water for AT LEAST 20 minutes. Call a physician IMMEDIATELY.</li></ul>	

	<b>WARNING</b> Batteries give off explosive gasses! DO NOT smoke. Sparking can ignite nearby flammable gasses, resulting in explosion and/or fire.
<ul style="list-style-type: none"><li>• DO NOT store, charge or service a battery near an open flame or any device that uses a pilot light or creates sparks.</li><li>• Before servicing the battery, disconnect the NEGATIVE (-) battery cable first, then disconnect the POSITIVE (+) battery cable. Arcing can occur when improperly disconnecting battery cables.</li></ul>	

The typical battery used is a 12 volt, lead acid, wet cell type. This battery is available as a maintenance-free or a dry-charged battery.

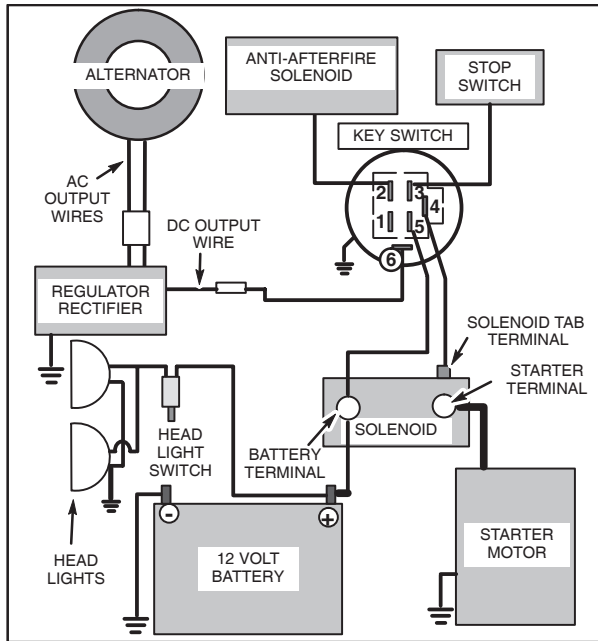
The wet-charged maintenance-free battery is filled with electrolyte and sealed at the time of manufacture. The electrolyte level cannot be checked.

The dry-charged battery is manufactured with fully charged plates. Electrolyte must be added when the battery is placed in service. Before activating a dry-charged battery, read and follow the manufacturer's procedure.

**NOTE:** Recommended battery sizes range from 30 ampere hour for warm ambient temperature service, to 50 ampere hour for the coldest ambient temperature service.

**Installation**

1. Before installing battery, connect all equipment to be operated. See typical wiring diagram, **Fig. 42**.
2. Place battery in holder with a flat base. Tighten hold downs evenly until snug. DO NOT over-tighten.
3. Connect POSITIVE terminal to POSITIVE (+) battery post first to prevent sparks due to accidental grounding. Tighten connectors securely.
4. Connect NEGATIVE terminal to NEGATIVE (-) battery post. Tighten connectors securely.



**Fig. 42**

**Test Battery**

1. Physical check – clean if necessary.
  - a. Corrosion
  - b. Dirt
  - c. Terminal and clamps (secure-good condition)
2. Bring battery to full charge.

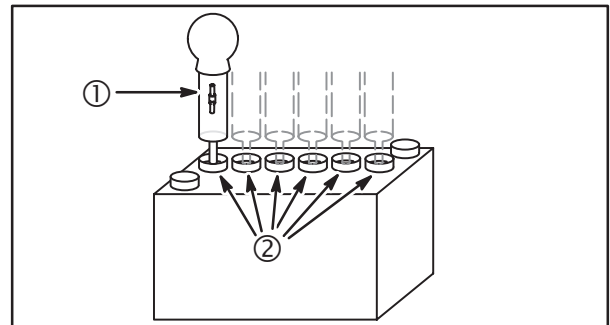
**CAUTION:** DO NOT exceed a charge rate of 1/10 ampere for every ampere of battery rating!  
 Consult battery manufacturer for charging recommendations.  
 Overcharging may cause battery failure.

- a. Use a taper charger (automatically reduces charge rate).

- b. Fill battery cells with distilled water after charging (for batteries that have been in service).

**NOTE:** If battery gets HOT to the touch, or is spitting acid (gassing) excessively, unplug charger periodically.

3. Use Digital Multimeter #19464. Set meter to read **DC Volts**.
4. Attach RED meter test clip to POSITIVE (+) battery terminal.
5. Attach BLACK meter test lead to NEGATIVE (-) battery terminal.
6. With ignition switch OFF, press starter button. If ignition and starter are run off the same switch, disconnect wires from spark plugs and ground the ignition using two Ignition Testers #19368.
7. Turn switch to START. Meter should display **9 volts** or more when cranking engine. If less than **9 volts**, replace battery.
8. With battery fully charged, check specific gravity readings of each cell (2) with a hydrometer (1) and record readings, **Fig. 43**. All readings should be above **1.250** (compensating for temperature). If specific gravity readings vary **.50** or if all cells read less than **1.225**, replace battery.



**Fig. 43**

**Charge Indicator Test**

- **SYMPTOM:** Charge Indicator Light Will Not Light – Key Switch ON – Engine Not Running

To identify whether the problem is related to the regulator/rectifier or the charging indicator wiring system, the test procedure must be followed in the sequence listed.

A known good battery is required for this test.

**NOTE:** Verify alternator and regulator/rectifier output before testing the charging indicator system.  
 Output values are the same as the 10 amp and 16 amp system.

A jumper wire is required for this test.

Make sure key switch is **OFF** before connecting jumper wire.

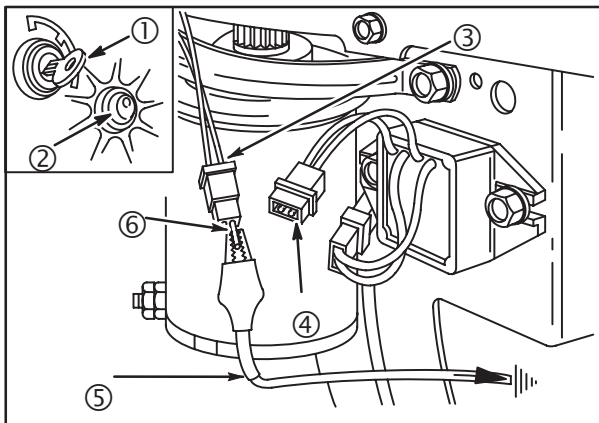
**NOTE:** Mark or identify the charging indicator wire in the output harness before disconnecting the harness from the connector.

**CAUTION:** If the jumper wire contacts the charging output wire during the test while the key switch is ON, the wiring harness could be damaged.

1. Disconnect output harness (3) at WHITE connector (4), **Fig. 44**.
  2. Attach one end of jumper wire (5) to a good ground.
  3. Attach other end of jumper wire (6) to charge indicator terminal in harness connector, **Fig. 44**.
    - a. Turn key switch to ON position (1).
    - b. If bulb (2) **LIGHTS**, charge indicator wiring system is OK. Replace regulator/rectifier.
    - c. If bulb **DOES NOT LIGHT**, replace bulb.
    - d. If new bulb does not light, the problem is an **OPEN CIRCUIT** (broken wire) in the charging indicator circuit. Refer to typical wiring diagram.
- **SYMPTOM:** Charge Indicator Light Stays ON – Engine Running.

**NOTE:** Indicator light will remain ON if battery voltage is **below 12 volts**.

4. Check indicator light wiring.
  - a. If wiring is grounded, light will remain ON when engine is running.
  - b. If wiring is OK, replace regulator/rectifier.

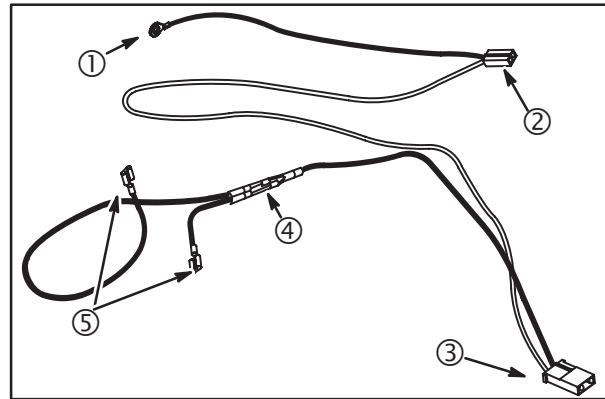


**Fig. 44**

## Testing Engine Wiring Harness

The engine wiring harness consists of a ground wire (1) with a diode (4) for each armature (5) and a separate wire (2) for the carburetor solenoid, **Fig. 45**. The engine wiring harness is connected to the wiring harness provided by the equipment manufacturer. A raised rib on the polarized connector (3) indicates the ground side.

See engine wiring harness diagram on the next page.



**Fig. 45**

### Ground Wires

Digital Multimeter #19464 is used for these tests.

In the Diode Test position, the meter will display the forward voltage drop across the diode(s). If the voltage drop is **less than 0.7 volts**, the meter will **BEEP** once and display the voltage drop. A **continuous tone** indicates **CONTINUITY** (shorted diode). An **INCOMPLETE CIRCUIT** (open diode) will be displayed as **OL**.

1. Insert RED test lead into **VΩ** receptacle in meter.
2. Insert BLACK test lead into **COM** receptacle in meter.
3. Rotate selector to **+)))))** (DIODE TEST) position.
4. Insert RED test lead clip into connector (1) (BLACK wire), **Fig. 46**. Leave attached for remainder of test.
5. Touch BLACK test lead probe to terminal (2).
  - a. If meter **BEEPS** once, diode is OK.
  - b. If meter makes a **CONTINUOUS TONE**, diode is shorted. Replace ground harness.
  - c. If meter displays **OL**, diode is open. Replace ground harness.
6. Repeat test for terminal (3). Results must be the same.

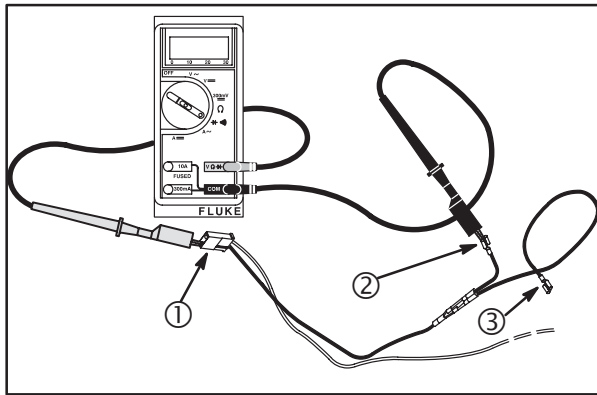


Fig. 46

**Engine Wiring**

1. With key switch **OFF**, re-connect equipment wiring harness to engine wiring harness. Disconnect harness at solenoid.
2. Insert RED meter test lead (2) into GRAY wire (1) in solenoid connector.

3. Attach BLACK test lead to a good ground, **Fig. 47**.
4. Turn key switch to **ON** position. Meter should display **battery voltage**.

If meter does not display battery voltage, replace engine wiring harness. If meter displays battery voltage, test the solenoid.

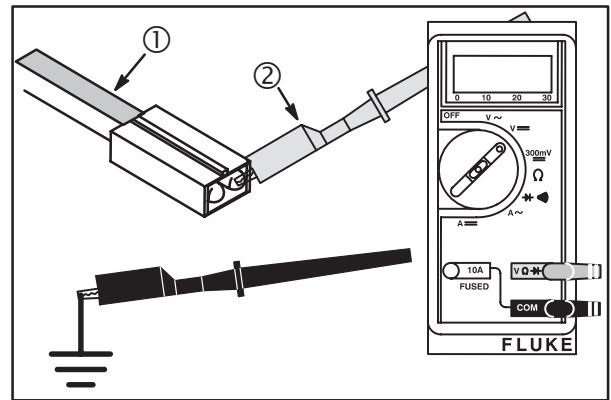
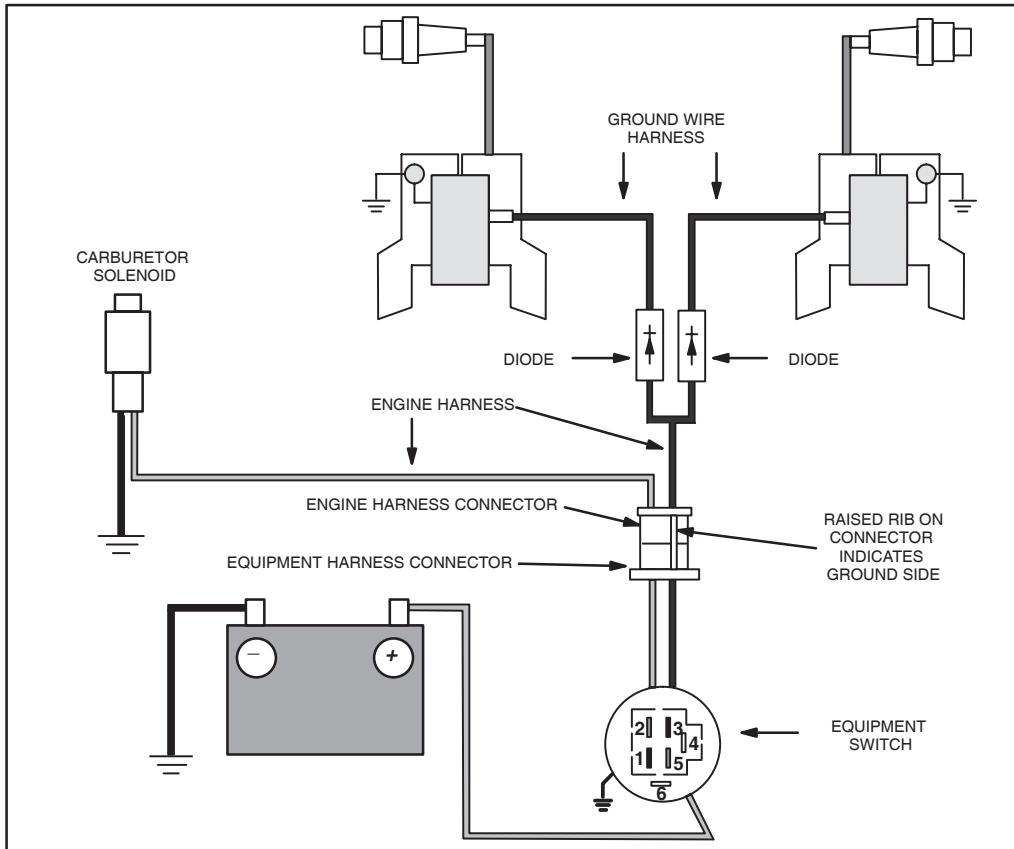


Fig. 47

## ENGINE WIRING HARNESS DIAGRAM



### DIODE FAILURE DIAGNOSIS

SWITCH ON	SWITCH OFF	CAUSE
Engine Runs On 1 Cylinder	Shuts Off OK	1 Closed Diode
Engine Runs (Both Cylinders)	Only One Cylinder Shuts Off	1 Open Diode
Won't Run (No Spark)		2 Closed Diodes
Engine Runs (Both Cylinders)	Engine Won't Shut Off	2 Open Diodes

## Oil Pressure

### Test Switch

Use Digital Multimeter #**19464**. Set meter to test for continuity.

Remove pressure switch. Connect one tester lead to the switch terminal and the other lead to the metal body of the switch, **Fig. 48**. The tester should indicate **CONTINUITY** when no pressure is applied to the switch. The switch should **OPEN** (no continuity) when approximately **4.5 PSI (0.3 Bar)** is applied. Replace the switch if test results are not to specification.

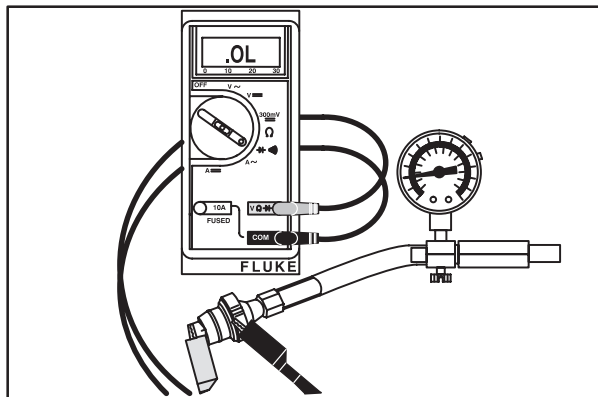


Fig. 48

If the oil pressure switch is within specification and the warning light remains ON, verify engine oil pressure with an oil pressure gauge.

### Test Pressure

1. Oil level must be between the LOW and FULL mark on dipstick. If oil level is low, check for leaks and add oil to FULL mark.
2. Remove pressure switch or 1/8" NPTF plug in oil filter adapter.
3. Install oil pressure gauge (1), **Fig. 49**.
4. Start engine. Run for approximately **5 minutes**.
5. Check oil pressure at **3000 RPM**.

Oil Pressure – measured @ **70° F (21° C)**:

- **10~50 psi (0.7~3.5 Bar)**

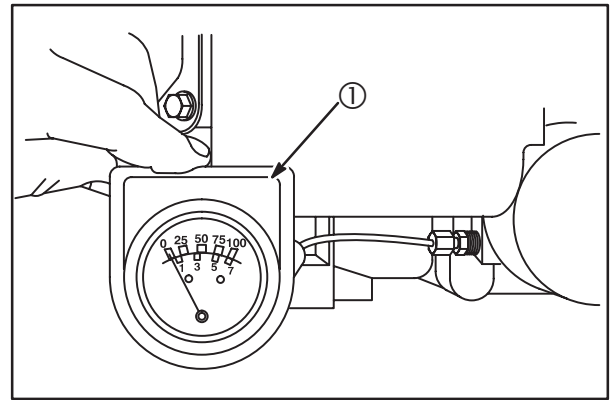


Fig. 49

### OIL PRESSURE TROUBLESHOOTING GUIDE

<b>Low Oil Pressure</b>	Engine RPM Too Low
	Wrong Viscosity or Diluted Oil
	Low Oil Level
	Broken Pressure Relief Spring
	Missing Pressure Relief Plunger
	Worn Bearings
Damaged or Defective Oil Pump	

<b>High Oil Pressure</b>	Wrong Viscosity Oil
	Plugged Oil Galleries
	Stuck Pressure Relief Plunger

### Panel Kit With Key Switch and Solenoid

Some V-Twin engines are equipped with a rotary key switch panel and starter solenoid. See wiring diagram for details.

#### Testing Key Switch

The rotary key switch can be checked for continuity using the Digital Multimeter #**19464**.

Remove carburetor cover with key switch. Disconnect wiring harness from key switch.

With meter selector switch in +))))) (DIODE TEST) position, and test leads attached to switch terminals, a **CONTINUOUS TONE** indicates continuity (complete circuit). **NO TONE** indicates no continuity (open circuit). An open circuit will be displayed as **OL**.

1. Insert RED test lead into **VΩ** receptacle in meter.
2. Insert BLACK test lead into **COM** receptacle.
3. Rotate meter selector to +))))) (DIODE TEST) position.
4. Meter must indicate **CONTINUITY** between terminals with key switch in position shown. See number sequence of terminals shown in **Fig. 50**.

**NOTE:** Terminals #1, #3 and #6 are grounded to key switch case when key switch is **OFF**. Meter must indicate **CONTINUITY** between these terminals and the key switch case when key switch is **OFF**.

When testing **RUN** and **START** terminals, meter should show **CONTINUITY** between terminals, with key switch in position shown.

**NOTE:** The #2 and #5 terminals should show **CONTINUITY** in both the **RUN** and **START** position.

Switch Position	Continuity
1. OFF	1+3+6
2. RUN	2+5+6
3. START	2+4+5

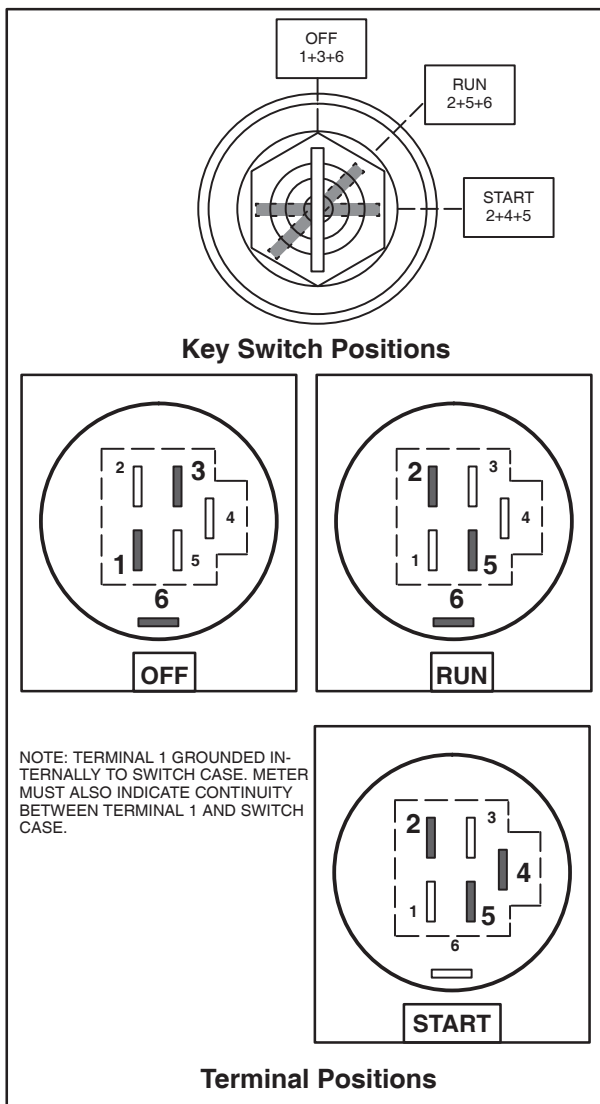
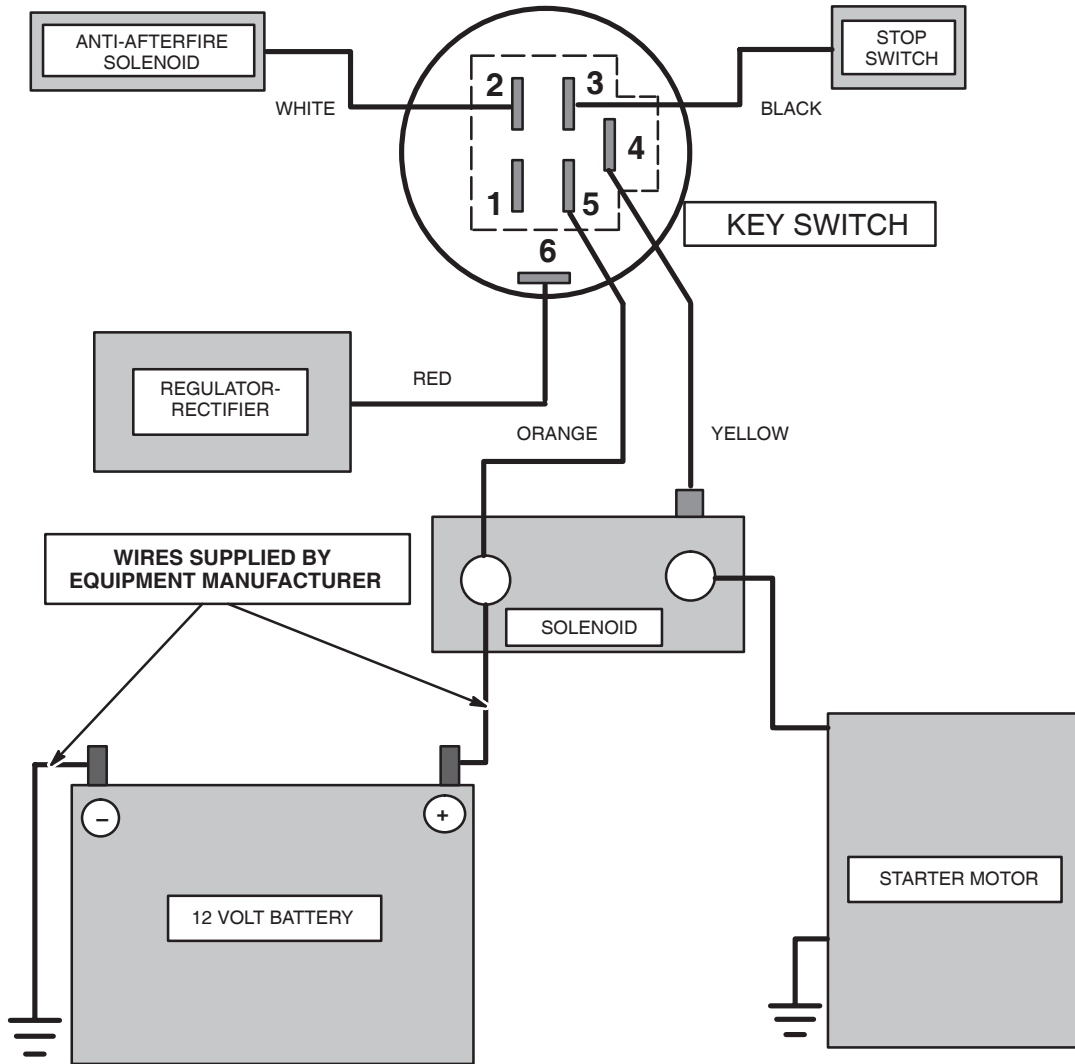


Fig. 50

## Wiring Diagram For Starter Panel & Key Switch For V-Twin Engines

Terminal No.	Wire Color	Function
1	Not Used	
2	White	To Carburetor Solenoid (when used)
3	Black	To Stop Switch Terminal On Engine
4	Yellow	To Solenoid (tab terminal)
5	Orange	To Battery (battery terminal on solenoid)
6	Red	To Regulator/Rectifier



Switch Position	Continuity
1. OFF	1+3+6
2. RUN	2+5+6
3. START	2+4+5



## Starter Motor

### Conditions Affecting Starter Motor Performance

1. Bound or seized starter motor bearings.
2. A shorted, open or grounded armature.
  - a. Shorted armature (wire insulation worn and wires touching one another) will be indicated by **LOW** or **NO RPM**.
  - b. Open armature (wire broken) will be indicated by **LOW** or **NO RPM** and excessive current draw.
  - c. Grounded armature (wire insulation worn and wire touching armature lamination or shaft) will be indicated by **excessive current draw** or **NO RPM**.
3. A defective starter motor switch.
4. Broken, damaged or weak magnets.
5. Dirty or binding starter drive.

### Troubleshooting

If a starting problem is encountered, check the engine to eliminate it as the cause of the problem. Check the engine for freedom of rotation by removing the spark plugs and turning the crankshaft over slowly by hand.

Test the battery, see page 47.

### Engine Cranks Slowly

- a. Additional load affecting performance (see above).
- b. Faulty electrical connection (battery circuit).
- c. Discharged battery (also see alternators).
- d. Dirty or worn starter motor commutator, bearing, weak magnets, etc.
- e. Worn brushes or weak brush spring.
- f. Wrong oil viscosity for temperature expected.
- g. Battery leads too long or wire too small.
- h. Battery too small.

### Engine Will Not Crank

- a. Faulty safety interlocks.
- b. Discharged or defective battery.
- c. Faulty electrical connections.
- d. Faulty starter motor switch (open circuit).
- e. Open circuit in starter motor.
- f. Brushes sticking, etc.
- g. Faulty solenoid.

### Starter Motor Spins But Does Not Crank Engine

- a. Sticking pinion gear due to dirt.
- b. Damaged pinion or ring gear.
- c. Starter clutch slipping.
- d. Battery faulty or damaged.
- e. Reverse rotation due to incorrect motor polarity – all motors rotate counterclockwise viewed from pinion gear.

### Starter Motor Spins But Does Not Stop

- a. Defective starter switch.
- b. Defective Solenoid

### Testing

A fully charged 12 volt battery (5) is required. Remove starter motor from the engine to test.

1. Assemble starter motor to test bracket.
2. Clamp test bracket in vise, **Fig. 51**.

**CAUTION:** Do not clamp motor housing in a vise or strike with a hammer. Starter motors contain ceramic magnets that can be damaged if the motor housing is hit, deformed or dented.

3. The DC Shunt (6) **MUST** be installed on the **NEGATIVE (-)** battery terminal as shown in **Fig. 51**.
  4. Insert **RED** test lead (4) into **VΩ** receptacle in meter. Connect to **RED** post terminal on shunt.
  5. Insert **BLACK** test lead (3) into **COM** receptacle in meter. Connect to **BLACK** post terminal on shunt.
  6. Rotate selector to **300mV** position.
  7. Connect a lead from the **POSITIVE (+)** battery terminal to the connector on the starter.
- NOTE:** If an optional starter switch (2) is **NOT USED** connecting the **POSITIVE** lead will activate the starter motor.
8. Activate the starter motor. Note reading on meter and RPM on tachometer (1).

**NOTE:** Take reading after meter stabilizes (approximately 2 – 3 seconds).

9. A starter motor in good condition will be within specifications listed.
  - **Minimum RPM – 6500**
  - **Maximum Amperes – 35**

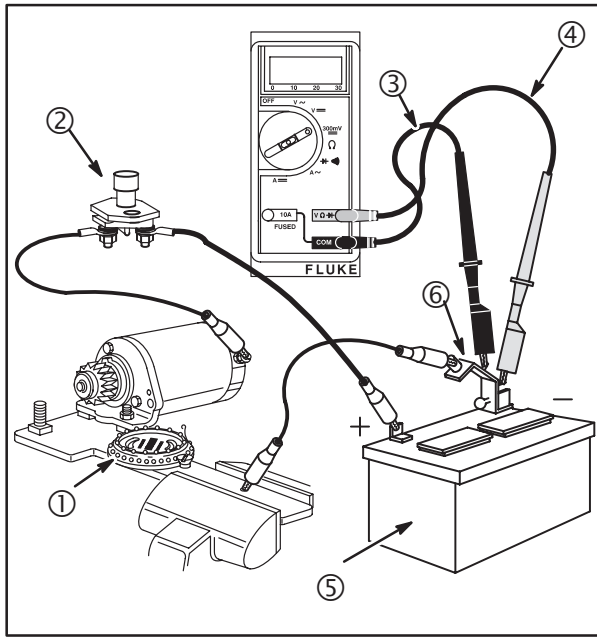


Fig. 51

### Solenoid Test

The starter solenoid is a normally open, electrically activated switch. When the key switch is turned to the START position, the switch closes, allowing battery current to flow to the starter motor and crank the engine.

1. The solenoid may be tested while mounted on engine. A jumper test lead (1) is required for this test.
2. Remove POSITIVE battery cable from battery. Remove battery cable from stud terminal on solenoid.
3. Disconnect YELLOW wire from tab terminal on solenoid.
4. Key switch must be in OFF position.
5. Insert RED test lead into  $V\Omega$  receptacle in meter.

6. Insert BLACK test lead into **COM** receptacle in meter.
7. Rotate meter selector to +))))) (DIODE TEST) position.
8. Attach one meter test lead to each stud terminal on solenoid (2, 3), **Fig. 52**.
9. Attach one end of jumper lead to POSITIVE terminal on battery (5).
10. Touch jumper wire to tab terminal (4) on solenoid.
  - a. An audible CLICK should be heard as the solenoid switch closes.
  - b. Meter should make a **CONTINUOUS TONE** (indicates continuity).

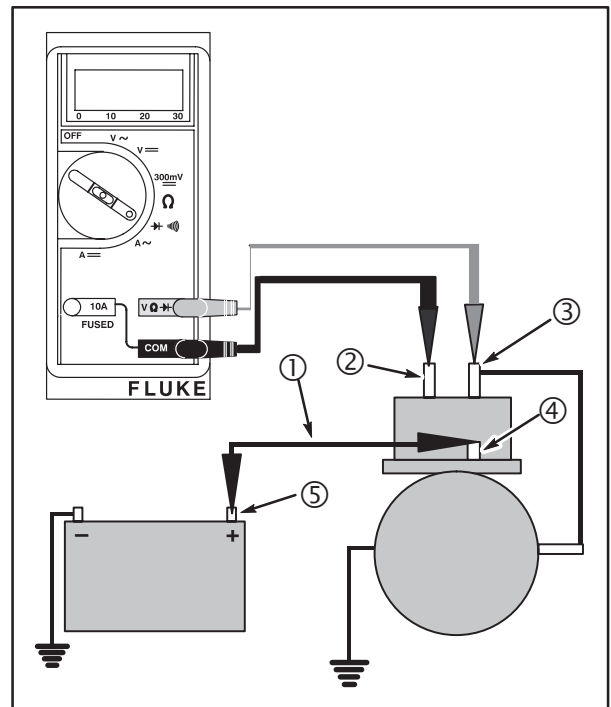
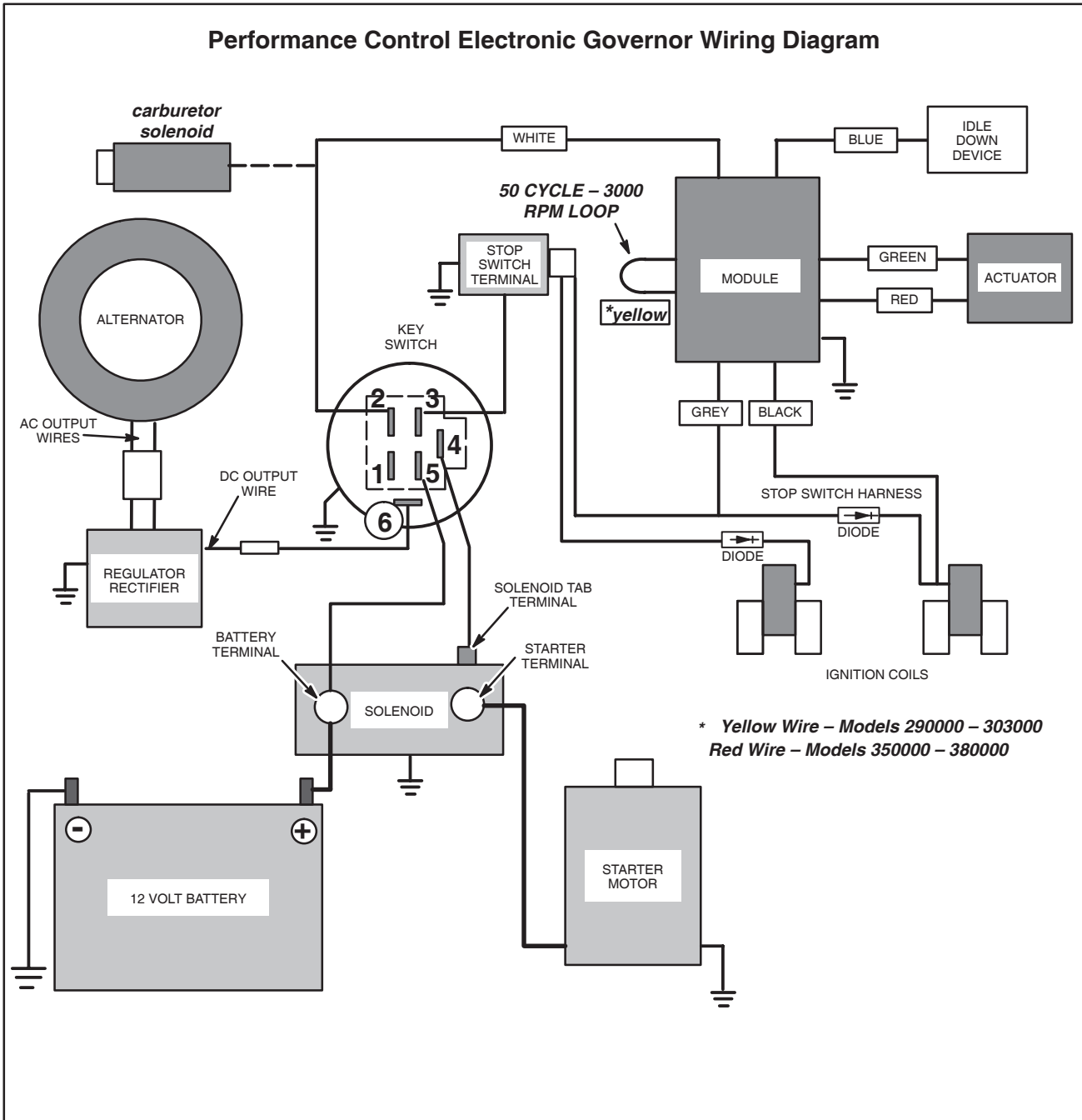


Fig. 52

# PERFORMANCE CONTROL™ ELECTRONIC GOVERNOR

Some V-Twin engines are equipped with the Performance Control™ electronic governor system for generator or welder applications. The electronic governor provides more responsive governing than a mechanical system. Engines equipped with the Performance Control™ electronic governor system have no mechanical governor components, and cannot be retrofitted to mechanical governor engines.

The Performance Control™ electronic governor control system consists of an electronic control module, wiring and stop switch harness and a throttle actuator. The control module is equipped with an idle-down circuit for applications requiring that feature. By cutting and removing the yellow or red loop wire, the control module can be converted to 50 cycle – 3000 RPM generator applications.

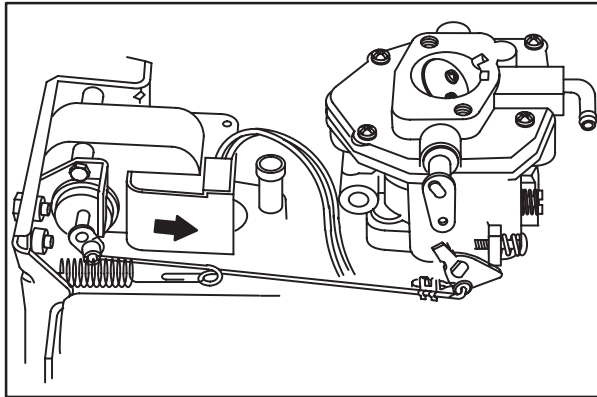


## Governor Test

### Dynamic Check

Perform dynamic check exactly in order shown.

1. Start engine and check RPM. Top governed speed should be:
  - a. 3600 RPM – 60 cycle applications.
  - b. 3000 RPM – 50 cycle applications (YELLOW or RED loop removed).
2. Manually move throttle link to wide open throttle (WOT), **Fig. 53**. Engine should not exceed 4000 RPM (approximately).

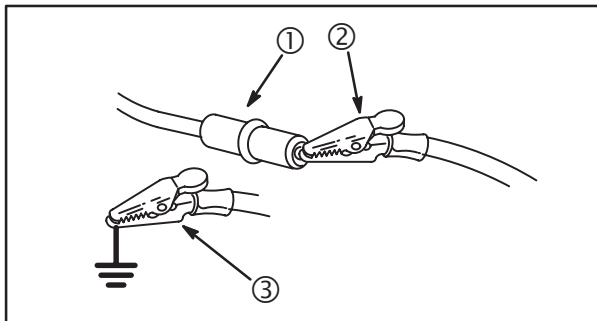


**Fig. 53**

3. With engine running at top governed speed, attach one end of a jumper (2) wire to BLUE wire from control module (1). Attach the other end of the jumper wire (3) to a good ground, **Fig. 54**. After 4 – 6 seconds engine speed should return to idle (approximately **1750 RPM**).

**NOTE:** Idle speed may vary according to equipment manufacturers specifications.

4. Remove jumper wire from ground. Engine should return to top governed speed.



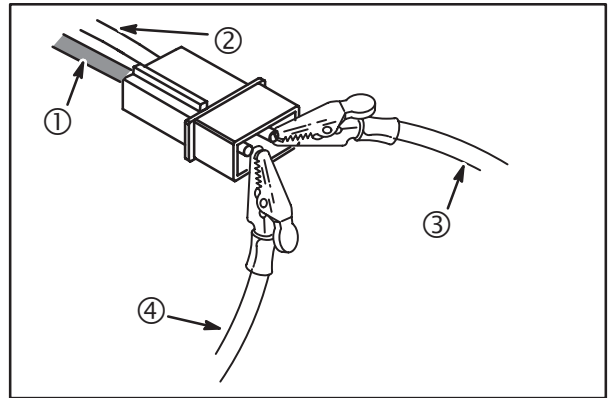
**Fig. 54**

### Static Check

To determine whether a governor problem is being caused by the actuator or the control module, perform the following static check exactly in order shown.

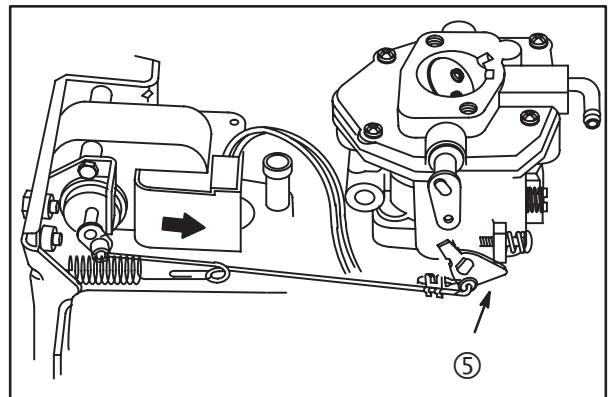
A pair of jumper wires and a known good 12 volt battery is required.

1. Disconnect RED (1) and GREEN (2) wires from control module to actuator.
2. Attach jumper wires from battery to RED and GREEN wires to actuator, **Fig. 55**.
  - a. Attach 12 volt + (POSITIVE, 4) to RED wire.
  - b. Attach 12 volt – (NEGATIVE, 3) to GREEN wire.



**Fig. 55**

3. Actuator should move throttle lever to wide open position (5), **Fig. 56**.
  - a. If actuator does not move it is defective. Replace.
  - b. If actuator moves throttle to WOT, position, the module is defective. Replace.



**Fig. 56**

## Replacing Actuator

### Removal

1. Disconnect RED and GREEN wires from control module to actuator.

2. Remove air cleaner assembly.
3. Disconnect governor link at carburetor.
4. Remove governor control bracket with actuator.
5. Disconnect governor link from actuator and remove throttle return spring.
6. Remove two screws, nuts and actuator from control bracket.

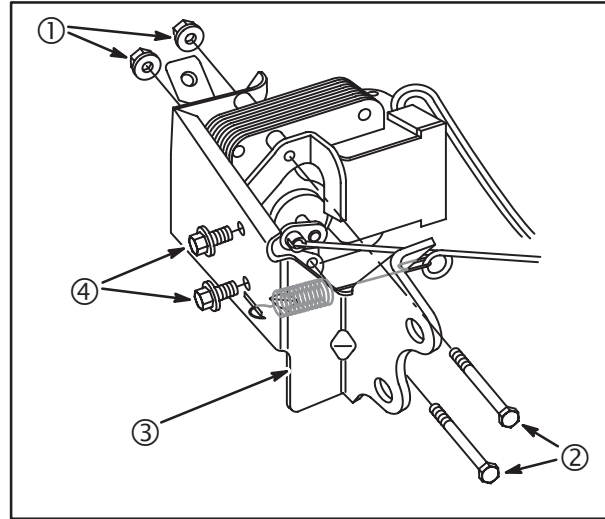
### Installation

1. Assemble actuator to governor control bracket (3), **Fig. 57**. Torque screws (4) and nuts (1) to **30 in. lbs. (3 Nm)**.

**NOTE:** Hold screws (2) with a wrench when torquing nuts. Screws must NOT turn while torquing nuts.

2. Assemble governor link to actuator. Make sure link snaps into hole in actuator grommet.
3. Assemble throttle return spring through slot in governor control bracket with open end of spring facing out and through small hole in governor bracket.
4. Assemble governor control bracket assembly to engine.

- a. Torque four 8mm screws to **150 in. lbs. (17 Nm)**.
- b. Torque two 6mm screws to **70 in. lbs. (10 Nm)**.



**Fig. 57**

5. Rotate actuator lever to position shown and connect governor link to carburetor.
6. Connect RED and GREEN wires from control module to actuator.

# GASEOUS FUELED ENGINES

## TROUBLESHOOTING GUIDE

Symptom	Potential Cause	Action
<b>Engine does not accelerate from low speed or high speed or run smoothly when loaded.</b>	Plugged vent ports on the regulator.	Remove plastic shipping plugs.
	Less than 11 inches of water pressure at the inlet of the secondary regulator.	Adjust the primary regulator output to 11 inches of water pressure. If natural gas supply is lower than 11 inches of water, a different secondary regulator may be required – consult OEM.
	More than 14 inches of water pressure at the inlet of the secondary regulator under full load.	Adjust the primary regulator to achieve 11 inches of water pressure while under load. <b>Note: If pressure at inlet of secondary regulator increases upon starting the engine, check primary regulator for holes or tears in the diaphragm or dirt on the inlet seat.</b>
	Plugged fuel filter.	Replace fuel filter.
	Kinked or obstructed fuel hose.	Remove the kink and/or replace the hose.
	No or low fuel in tank.	Refuel the tank.
	Propane tank is too small.	Appropriately size the fuel tank for the engine horsepower and lowest ambient temperature.
	Fuel transfer solenoid in the wrong position.	When the fuel solenoid is energized or if the main mixture adjustment screw is completely seated, the engine is configured for propane gas (mixture too lean for natural gas). If the fuel solenoid is not energized, the engine is configured for natural gas (mixture too rich with propane).
	Carburetor not adjusted properly (natural gas only).	Readjust the mixture needles on the carburetor.
	Air leak in the fuel line from secondary regulator to carburetor.	Tighten the clamps or replace the hose.
	Holes, tears or damaged diaphragm in secondary regulator.	Replace damaged part.
	Debris on inlet needle of regulator.	Clean system of debris and add a fuel filter. Use liquid pipe sealant – do not use Teflon tape.

## TROUBLESHOOTING GUIDE (CONTINUED)

2

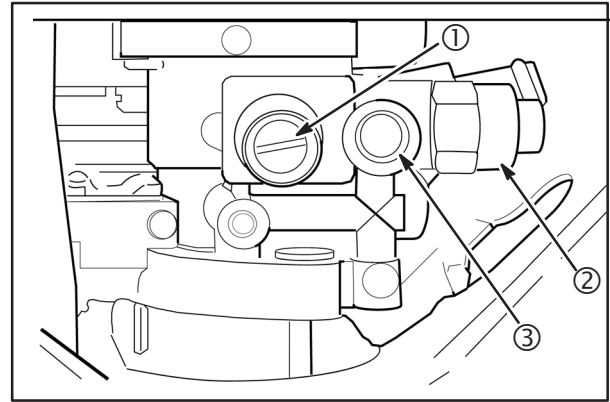
<b>Engine will not start.</b>	Out of fuel.	Refuel the tank.
	Fuel supply shut off.	Open fuel tank.
	Filter or vacuum lock off is not opening.	Check for proper operation of all fuel lock-off (safety) devices. If electrically actuated, check for dead battery or blown fuse. Replace lock-off device if it is not functioning properly.
	Vacuum leak in the vacuum lock-off device.	Replace vacuum line or tighten clamps. Replace vacuum lock-off if damaged.
	Filter is plugged.	Replace filter.
<b>Frost forming on the regulator or on the fuel line – liquid (not vapor) entering the system.</b>	Wrong type of propane tank – set up for liquid withdrawal	Replace the fuel tank or change to the vapor withdrawal port.
	Tank is positioned incorrectly (typically tanks that lay on their side).	Fuel tanks have a receptacle for a locator pin that orients the tank for a specific withdrawal. Pin may be in the wrong location or missing. Reposition tank.
	Fuel tank is overfilled.	Fill to labeled tank capacity only.
	Fuel tank is too small, especially if the ambient temperature is low.	Increase the size of the fuel tank to increase the vaporization rate of the fuel. Consult with local gas supplier.
	Restriction within the fuel line.	Remove restriction or replace damaged part.
<b>Gas will not stop flowing after engine is stopped.</b>	Regulator is not adjusted properly.	Adjust the regulator so that when the outlet tube is placed in water, a gas bubble just begins to form. Back off on the adjustment so that the bubble is maintained but does not grow.
	Atmospheric side of the secondary regulator is pressurized.	Remove plastic shipping plugs or revise the regulator venting.
	Debris on inlet needle of secondary regulator.	Clean the system of debris and install a fuel filter. Use liquid pipe sealant – do not use Teflon tape.
	Regulator not positioned vertically.	Regulator may only be positioned with the outlet pointing straight up. A directional arrow is also shown on the smooth side of the regulator.
<b>Gas leak from fuel line.</b>	Loose fitting.	Tighten fitting – replace if damaged.
	Damaged, cracked or worn hose.	Replace hose.
<b>Gas leak from regulator.</b>	Damaged diaphragm in regulator.	Replace damaged part.

## GASEOUS FUEL CARBURETOR ADJUSTMENT

Some Briggs & Stratton V-Twin engines were available factory-built to operate on liquefied petroleum gas (LPG) or natural gas (NG). To maintain the California Air Resource Board (CARB) emissions certification on these engines, the Original Equipment Manufacturer (OEM) must use specific equipment and procedures to complete the installation. The following describes the OEM requirements. Always have a certified LPG/NG technician perform repairs on gaseous fuel systems.

**NOTE:** The main adjustment is the large brass adjustment screw (1) just to the left of the solenoid (2) and capped port (3), **Fig. 58**. The idle adjustment is located below and to the left of the main adjustment. An accurate CO meter is required to adjust the gaseous fuel mixture.

1. Start the engine. Set the main mixture adjustment at high speed under load to achieve **1/2 – 1% CO** in the exhaust.
2. Allow the engine to warm up at top speed for **2 minutes**.
3. Slow the engine to between **1100 – 1750** no-load RPM. Adjust the idle mixture to achieve **1/2 – 1% CO** in the exhaust.
4. Return the engine to high speed full-load. If required, readjust the setting to **1/2 – 1% CO**.
5. Stop the engine. Install the anti-tampering plugs.



**Fig. 58**

### LPG-Only Operation

**NOTE:** If the application is designed so that the engine normally operates on NG, but defaults to LPG if the NG supply is interrupted, no adjustments for LPG operation are required. The following steps describe the setting procedure when the engine is ONLY powered by LPG.

1. Follow steps 1 through 4 above. The same components (regulators, lock-off, fuel lines, etc.) used with the NG installation are used for the LPG installation.
2. Connect the fuel transfer solenoid to a **12 volt DC** power supply. As an alternative the main adjustment screw may be turned in until completely seated eliminating the need for applying power to the solenoid.
3. Start the engine and run it at top speed for **2 minutes** to warm up. The engine uses a fixed main jet for LPG operation, no adjustment is necessary.
4. Slow the engine to **1100 – 1750 RPM** no-load. Adjust the idle mixture to achieve a reading of up to **3% CO**.
5. Stop the engine. Install the anti-tampering plugs.



## EQUIPMENT PROBLEMS AFFECTING ENGINE OPERATION

Frequently, what appears to be an engine problem may be the fault of the equipment powered rather than the engine itself. Since many types of equipment are powered by Briggs & Stratton engines, it is impossible to list all the conditions that can exist. Listed below are some common equipment problems, and what to look for as the probable cause.

### ***Hard Starting or Will Not Start***

1. Loose belt or blade – a loose belt or blade can cause a backlash effect that will counteract engine cranking effort.
2. Starting under load – be sure the unit is disengaged when engine is started; if the unit remains engaged, it should not have a heavy load when starting.
3. Check remote control assembly for proper adjustment.
4. Check interlock system for shorted wires, loose or corroded connections, or defective modules or switches.

### ***Engine Will Not Stop***

1. Check equipment ignition stop switch.

2. Check for loose or disconnected equipment stop switch wire.
3. Check ground wire harness (current style) or ground terminal (early style) on engine. See test procedure.

### ***Vibration***

1. Cutter blade bent or out of balance – remove and balance.
2. Mounting bolts loose – tighten bolts.

### ***Power Loss***

1. Bind or drag in unit – If possible, disengage engine. Operate unit manually to check for binding.
2. Grass cuttings built-up under deck.
3. No lubrication in transmission or gear box.
4. Excessive drive belt tension may cause seizure.

### ***Noise***

1. Cutter blade coupling or pulley – an oversize or worn coupling can result in knocking, usually under acceleration. Check for fit or tightness.
2. No lubricant in transmission or gear box.

# Section 3

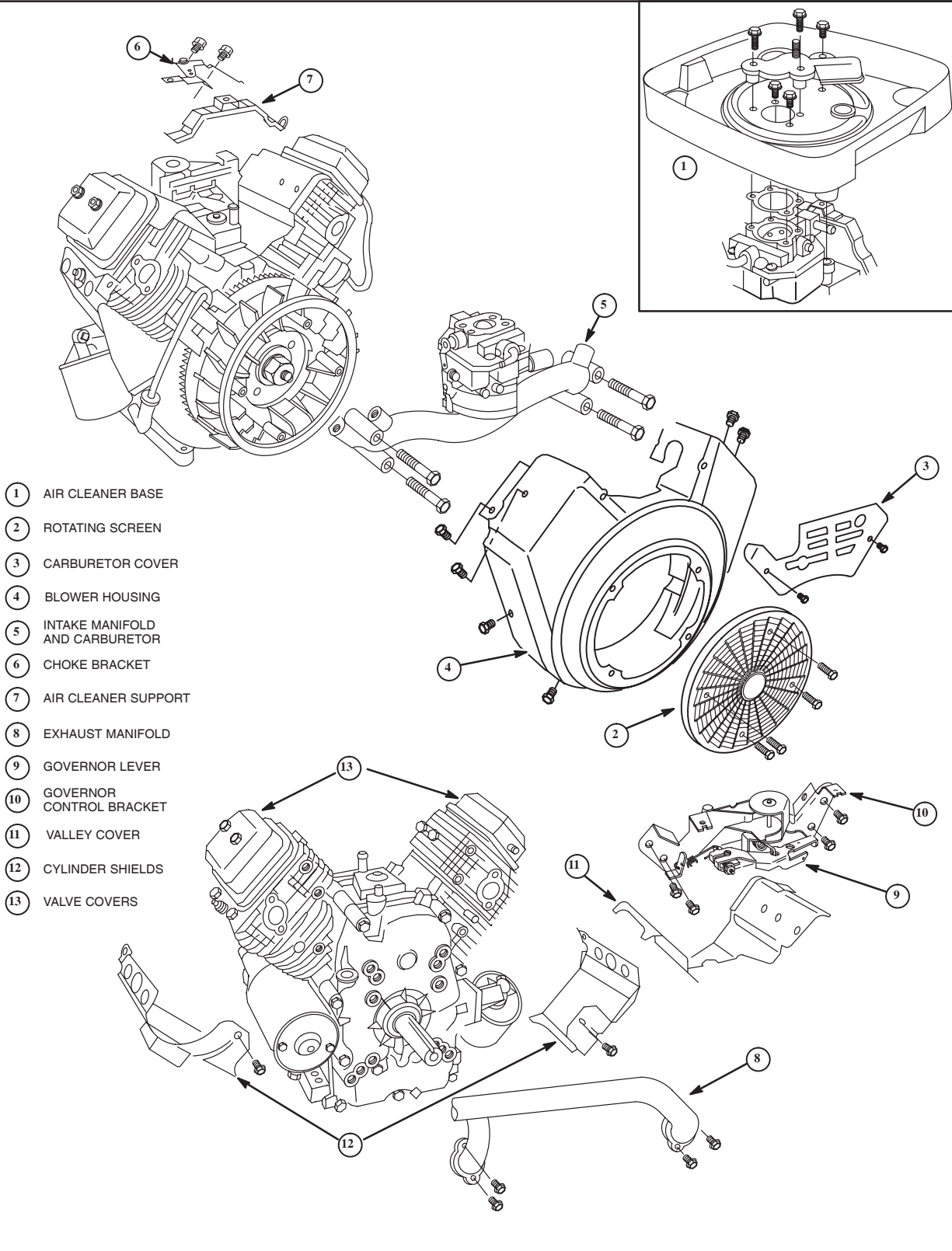
## Engine Disassembly

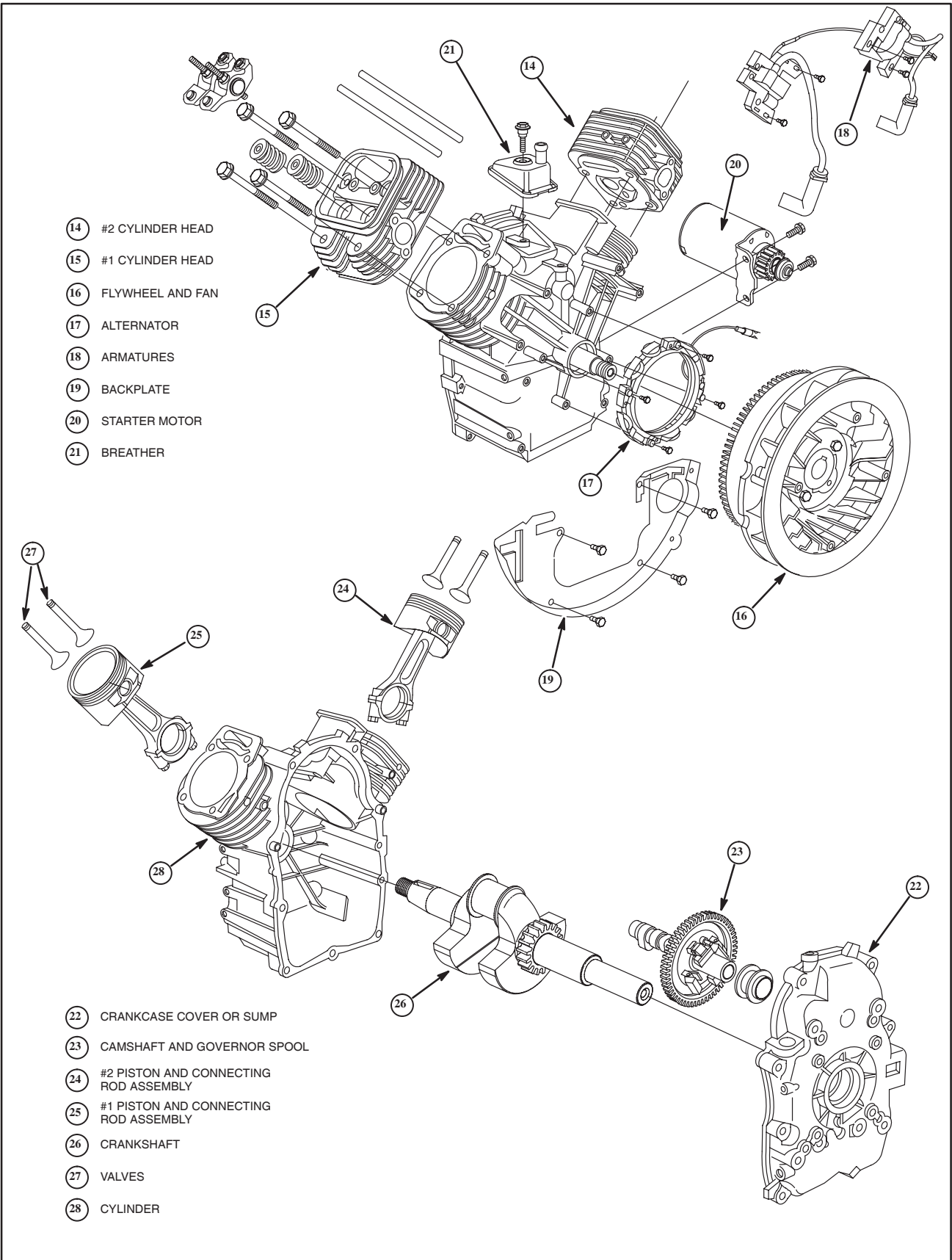
---

	Page
AFTER DISASSEMBLY .....	74
ENGINE DISASSEMBLY .....	68
Preparation .....	68
Remove Air Cleaner Assembly .....	68
Vertical Crankshaft – Models 290700–380700 .....	68
Horizontal Crankshaft – Models 290400–350400 .....	68
Horizontal Crankshaft – Models 351400–380400 .....	69
Horizontal Crankshaft – Models 540000–610000 .....	69
Remove Blower Housing and Fan .....	69
Remove Carburetor and Intake Manifold .....	70
Vertical Crankshaft – All Models .....	70
Horizontal Crankshaft – All Models .....	70
Remove Control Bracket .....	70
Remove Armatures .....	70
Remove Flywheel .....	71
Flywheel Nut – 290000, 300000, 540000, 610000 .....	71
Flywheel Nut – 350000, 380000 .....	71
Flywheel Nut – All Models Except Powerlink™ .....	71
Flywheel Nut – Powerlink™ .....	72
Remove Breather and Starter Motor .....	73
Remove Cylinder Head .....	73
Remove Oil Pump .....	73
Remove Camshaft .....	74
Remove Pistons and Connecting Rods .....	74
Remove Crankshaft .....	74
PARTS IDENTIFICATION .....	66

# PARTS IDENTIFICATION

3





## ENGINE DISASSEMBLY

### Preparation

- Drain oil. Remove and discard oil filter.
- Disconnect choke and throttle control cables.
- Remove engine from equipment.
- Remove spark plugs.
- Remove muffler and exhaust manifold.

## 3

### Remove Air Cleaner Assembly

#### Vertical Crankshaft – Models 290700 – 380700

**Current style: (Round cartridge), Fig. 1.**

1. Remove air cleaner cover, cartridge and pre-cleaner.
2. Remove three screws (2) and breather deflector (3).
3. Remove two carburetor mounting nuts (1).
4. Remove air cleaner base and breather tube.

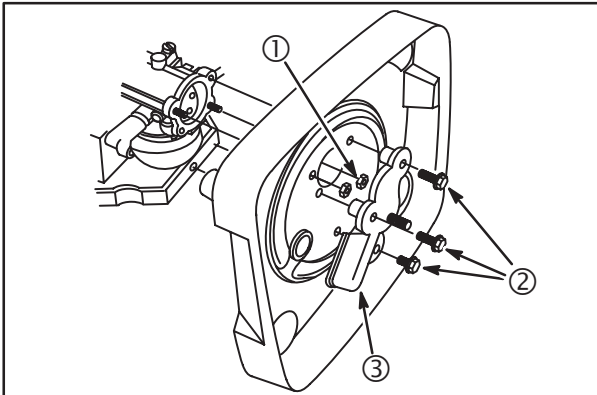


Fig. 1

**Early style: (Square cartridge), Fig. 2.**

1. Remove air cleaner cover.
2. Remove four screws (6), lock washers (4) and flat washers (7).
3. Remove air cleaner base (5) and breather tube.

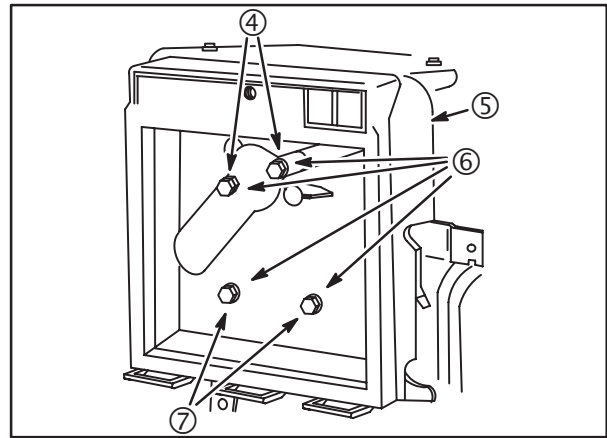


Fig. 2

#### Horizontal Crankshaft Models 290400 – 350400

**Current style: (Round cartridge), Fig. 3.**

1. Remove air cleaner cover, cartridge and pre-cleaner.
2. Remove three screws (1) and breather deflector (2).
3. Remove two air cleaner base mounting screws (3).
4. Remove air cleaner base (4) and breather tube.

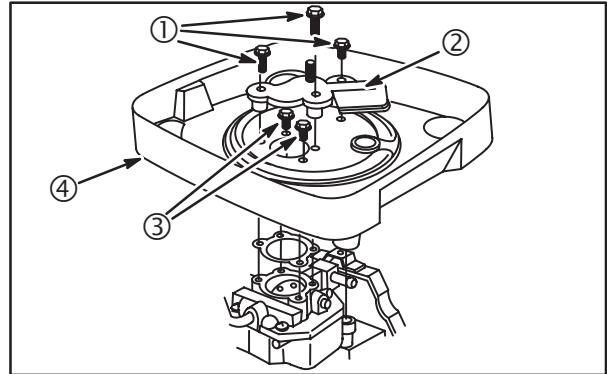


Fig. 3

**Early style: (Square cartridge), Fig. 4.**

1. Remove air cleaner cover.
2. Remove four screws (2).
3. Remove air cleaner base (1) and breather tube.

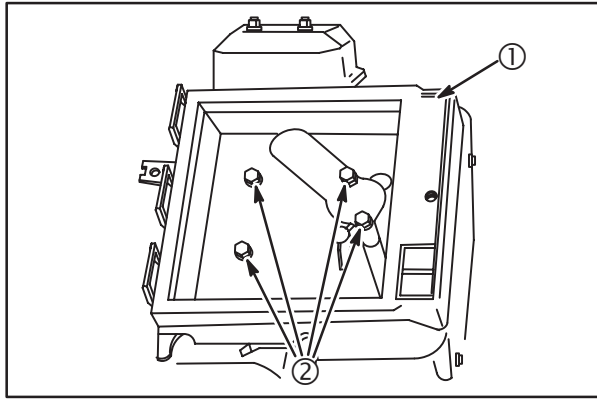


Fig. 4

### Horizontal Crankshaft – Models 351400 – 380400

1. Remove air cleaner cover, cartridge and pre-cleaner.
2. Remove five screws (1) and carburetor shield (2), Fig. 5.
3. Disconnect breather tube at air cleaner base and remove air cleaner base (3).

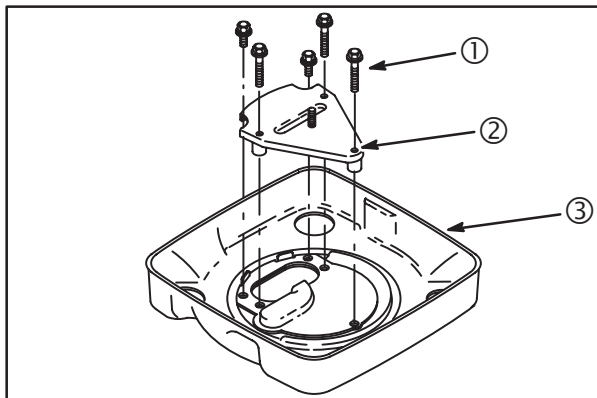


Fig. 5

### Horizontal Crankshaft – Models 540000, 610000

1. Loosen the clamp (1) for the air inlet hose, Fig. 6.
2. Remove two mounting band screws (2). Remove the air cleaner assembly.

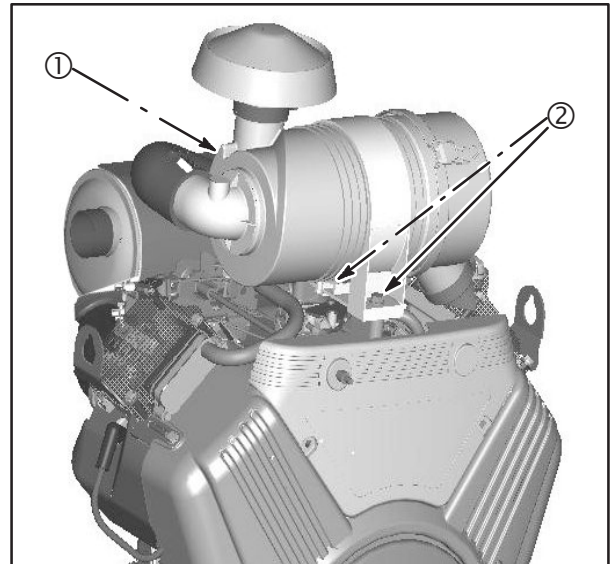


Fig. 6

### Remove Blower Housing and Fan

1. Remove blower housing (1) and debris screen (2), Fig. 7.

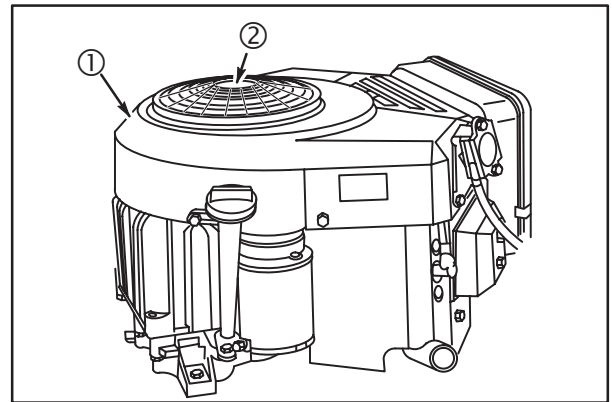


Fig. 7

2. Remove two screws (5), fan retainer (6) and fan (7), Fig. 8.

**NOTE:** If engine is equipped with rewind starter hub (4), remove starter hub screw (3) first.

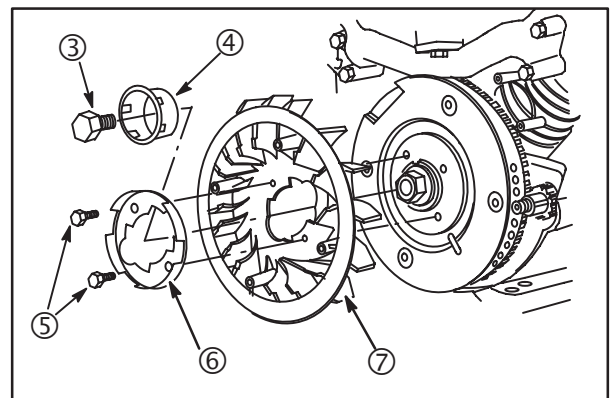


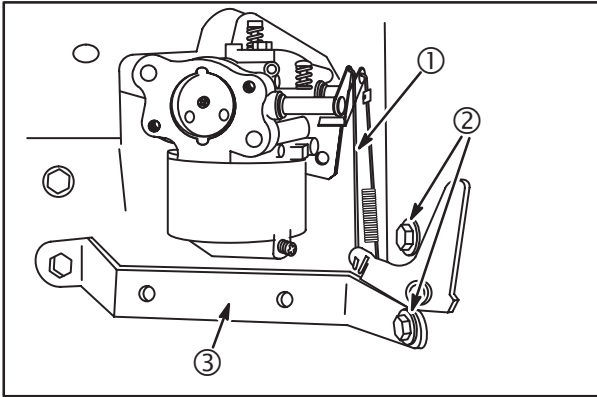
Fig. 8

## Remove Carburetor and Intake Manifold

### Vertical Crankshaft, All Models

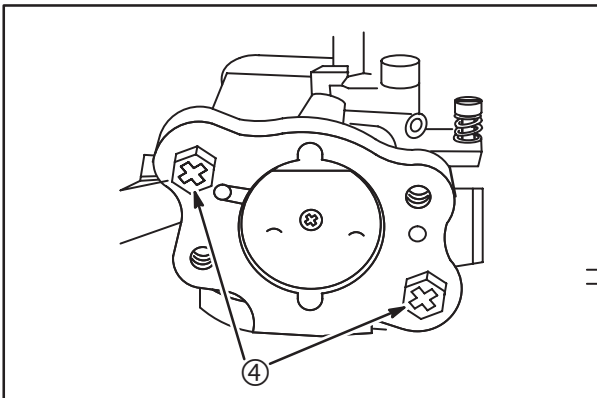
1. Remove air cleaner assembly.
2. Remove two screws (2) and choke control bracket, **Fig. 9**.
3. Disconnect choke link (1) from carburetor.

**NOTE:** If engine is equipped with anti-afterfire solenoid, air cleaner bracket (3) must be removed **BEFORE** removing carburetor, **Fig. 9**.



**Fig. 9**

4. Remove carburetor mounting screws (4) and carburetor, **Fig. 10**.



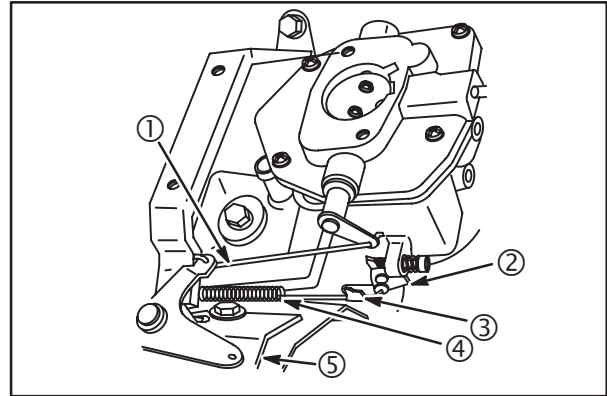
**Fig. 10**

### Horizontal Crankshaft – All Models

**NOTE:** Disconnect anti-afterfire solenoid wire from equipment switch wire. Remove blower housing.

1. Remove two screws and choke control bracket (5), **Fig. 11**.

2. Disconnect choke link (1) from carburetor.
3. Disconnect fuel line at carburetor.
4. Disconnect governor link and spring (4) from retainer (3) and throttle lever (2).
5. Disconnect governor link.

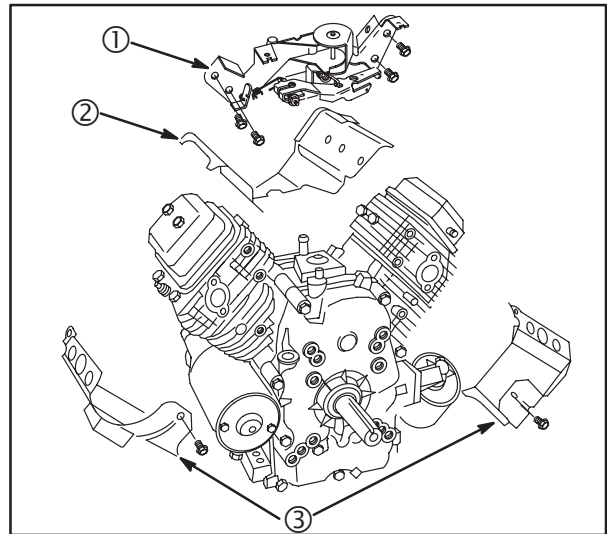


**Fig. 11**

6. Disconnect fuel line at carburetor.
7. Remove intake manifold and gaskets.

## Remove Control Bracket

1. Remove governor control bracket (1), **Fig. 12**.
2. Remove valley cover (2) and cylinder shields (3).



**Fig. 12**

## Remove Armatures

1. Disconnect stop switch wires at armatures.
2. Remove armature screws and lift off armatures (1), **Fig. 13**.

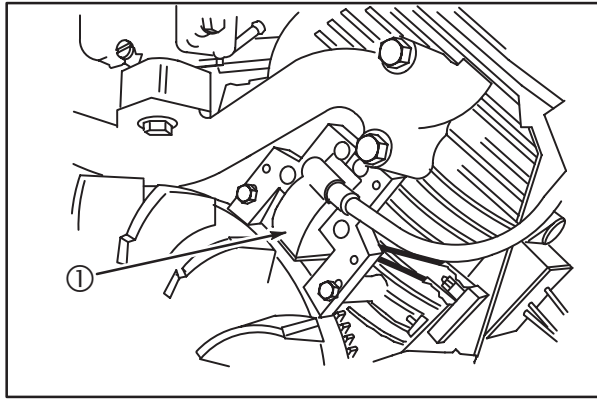


Fig. 13

## Remove Flywheel

### Flywheel Nut – Models 290000, 303000, 540000, 610000

1. Prevent the flywheel from turning with Flywheel Strap Wrench, #19433 (5) around outer rim of flywheel, Fig. 14.
2. Turn the flywheel nut COUNTERCLOCKWISE (arrow) with a 1/2" breaker bar (4) and a 30 mm socket to remove.

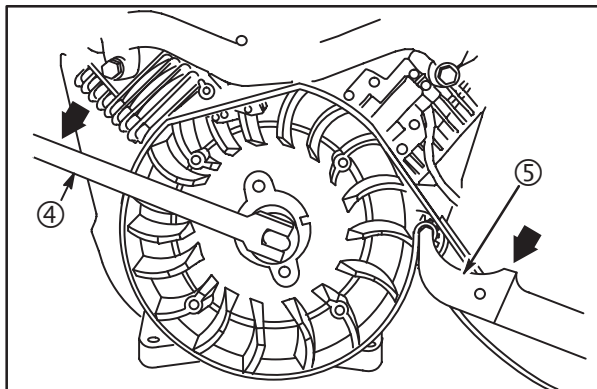


Fig. 14

### Models 350000, 380000

1. Place Flywheel Holder #19321 (6) on fan retainer with lugs of flywheel holder engaging slots on the fan retainer, Fig. 15.

**NOTE:** If engine is equipped with rewind starter hub remove starter hub screw first. Then remove flywheel nut.

2. Turn the flywheel nut COUNTERCLOCKWISE (arrow) with a 1/2" breaker bar (4) and a 30 mm socket to remove

**NOTE:** Do not remove fan retainer and fan at this time.

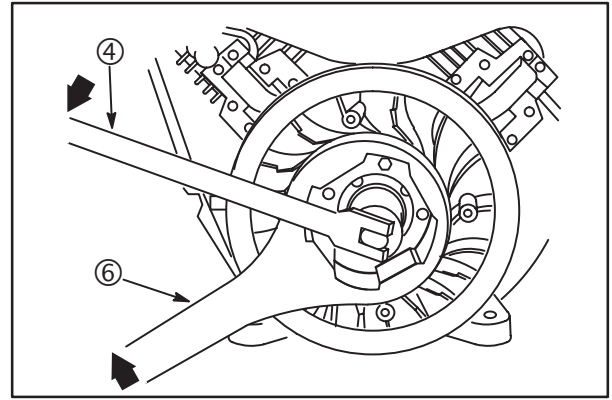


Fig. 15

### Flywheel – All Models EXCEPT Engines with PowerLink™

**NOTE:** See the special procedure at the end of this section for flywheel removal on engines with the PowerLink™ system.

1. Reinstall flywheel nut (2). Turn nut down flush with top of threads, Fig. 16.
2. Install Flywheel Puller #19203 (1).
3. Tighten puller screws equally until flywheel loosens.

	<b>CAUTION</b>
	<b>AVOID INJURY!</b>
<ul style="list-style-type: none"> <li>• DO NOT strike the flywheel with a hard object or a metal tool. This could cause the flywheel to shatter in operation.</li> <li>• Use approved flywheel removal tools.</li> </ul>	

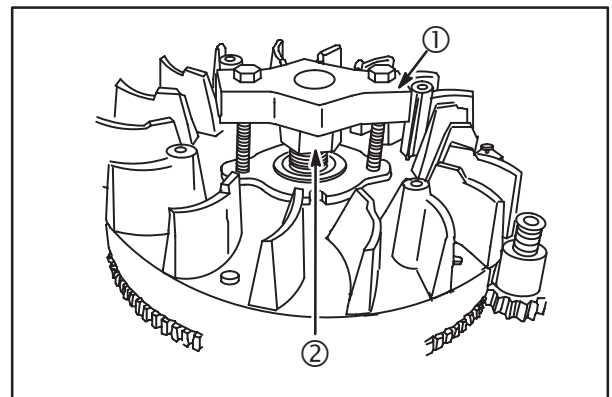


Fig. 16



## Flywheel – Models WITH PowerLink™



**CAUTION**

**AVOID HAND AND/OR FINGER INJURY!**

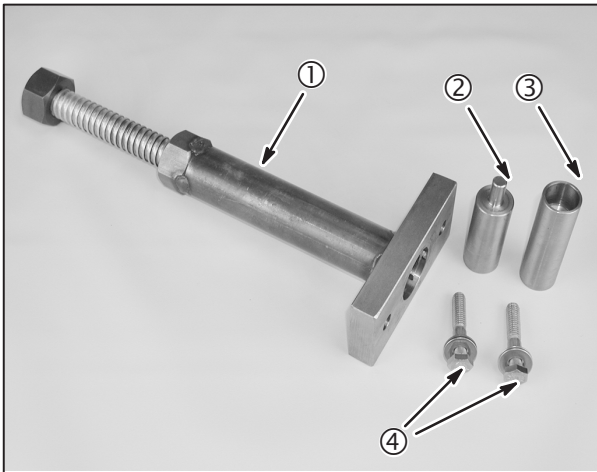
- The flywheel magnets are **VERY POWERFUL** and can rapidly draw the flywheel to the engine. Exercise caution and use the proper tools when servicing the flywheel.

**3**

### Required Tools

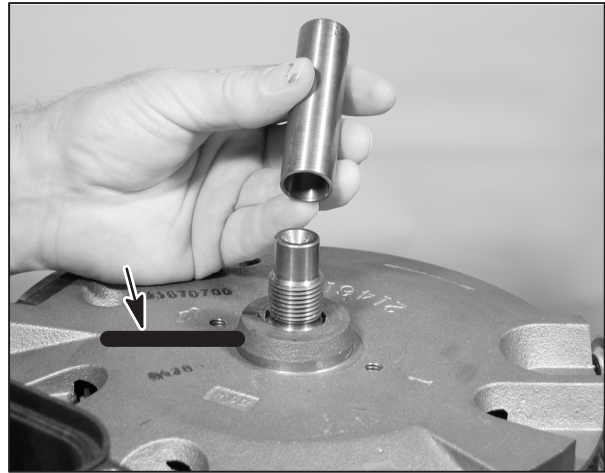
**NOTE:** The components of Flywheel Puller #19534, are shown in **Fig. 17**. This tool is **REQUIRED** to service the flywheel on engines with the PowerLink™ system.

1. Puller
2. Vanguard™ Pilot
3. Intek™ Pilot
4. Screws



**Fig. 17**

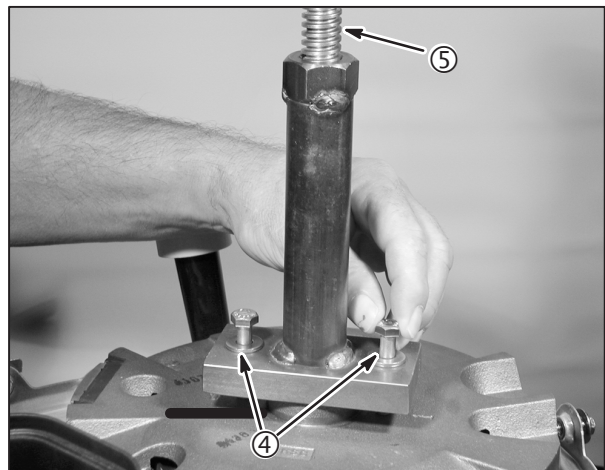
1. Remove the ignition coils from the engine.
2. Remove the flywheel nut, fan retainer and fan from the flywheel.
3. Mark the flywheel (arrow) as shown to locate the flywheel keyway when reinstalling, **Fig. 18**.
4. Install the correct pilot over the crankshaft as shown.



**Fig. 18**

5. Place the flywheel puller over the pilot. Back out the puller screw (5) until the flange on the puller is flush with the flange on the flywheel, **Fig. 19**.
6. Align the holes in the puller flange with the holes in the flywheel. Install the puller screws (4) and tighten until the screws are flush with the flange on the puller.
7. While holding the hex on the puller, tighten the puller screw until the flywheel loosens.
8. Continue tightening the puller screw until the flywheel is clear of the stator and can be lifted from the crankshaft. Leave the puller screw in this position.
9. Leave the puller attached to the flywheel, and place the flywheel on a clean work surface with the ring gear side down, until the flywheel is ready to be installed.

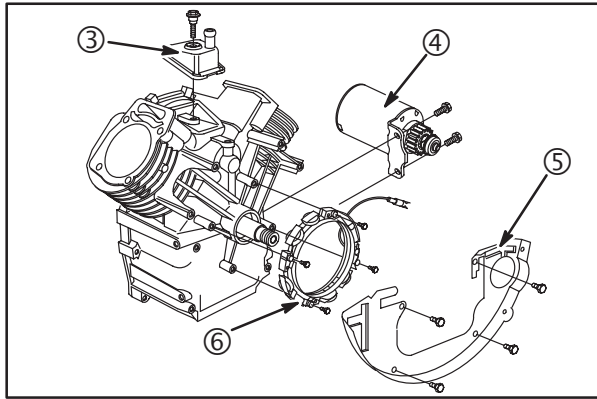
**CAUTION:** Use extreme care when handling the flywheel. The alternator magnets are fragile and easily damaged.



**Fig. 19**

## Remove Breather and Starter Motor

1. Remove breather (3), alternator (6), backplate (5) and starter motor (4), **Fig. 20**.



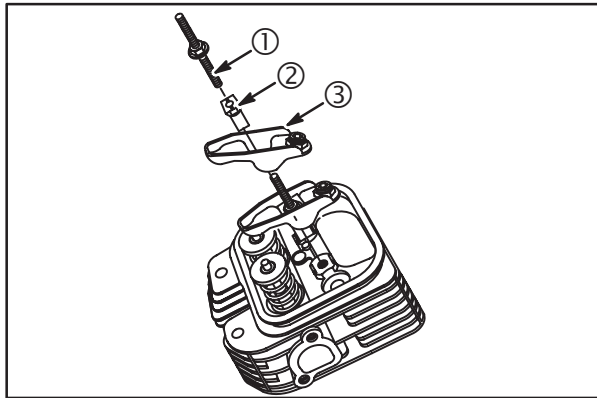
**Fig. 20**

2. Remove crankcase cover/sump.

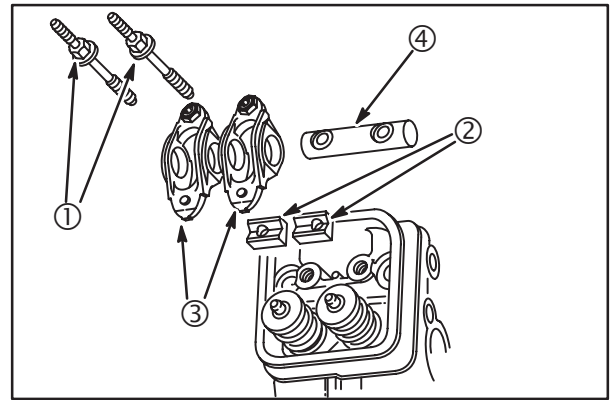
## Remove Cylinder Head

1. Remove two rocker studs (1) supports (2) and rocker arm assemblies (3), **Fig. 21** (current) or **Fig. 22** (early). Remove rocker arm shaft (4, early versions).
2. Remove push rods.

**NOTE:** Label push rods for reassembly in the original location.



**Fig. 21**

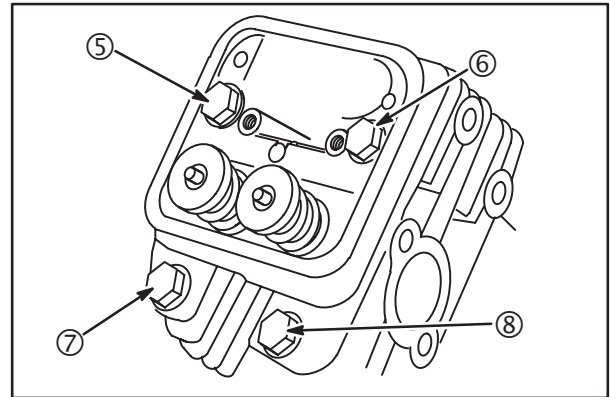


**Fig. 22**

3. Remove head bolts (5, 6, 7, 8) and cylinder head, **Fig. 23**. Discard cylinder head gasket.

**NOTE:** Engines manufactured before 940501xx were equipped with sealing washers under cylinder head bolts (5) and (6).

Repeat for other cylinder head.



**Fig. 23**

## Remove Oil Pump

1. Remove gear baffle (1) and oil pump (2) with pickup (4) from crankcase cover (horizontal crankshaft engines), **Fig. 24**, or sump (vertical crankshaft engines), **Fig. 25**.

**NOTE:** Discard all O-rings (3).

2. Remove oil pickup from oil pump.

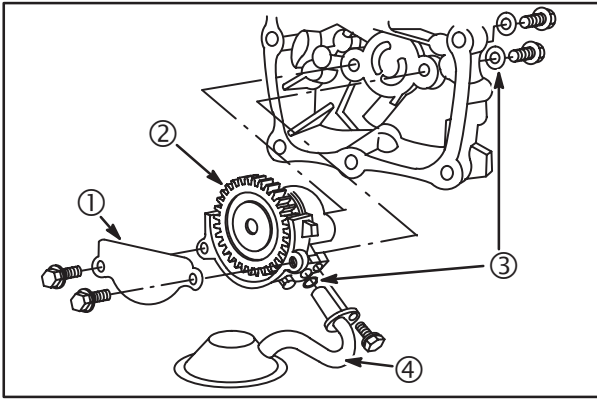


Fig. 24

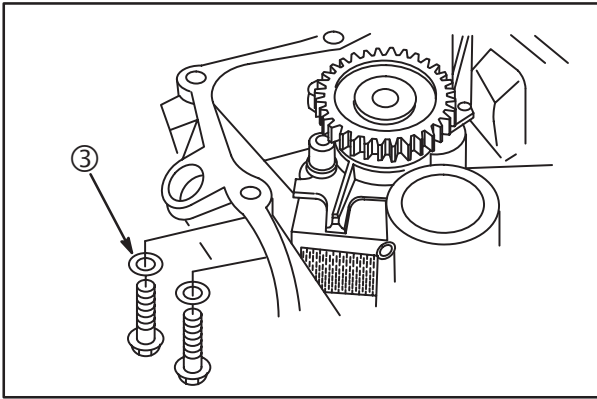


Fig. 25

### Remove Camshaft

1. Remove governor spool (8) from camshaft (7), **Fig. 26**. Discard gasket and O-ring.
2. Rotate crankshaft and camshaft until timing marks (9) align. Remove camshaft.
3. Remove tappets.

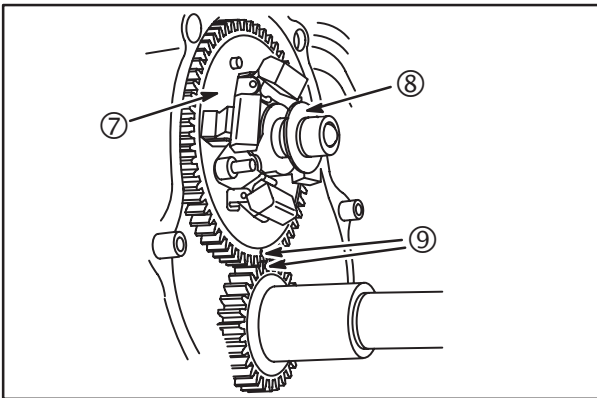


Fig. 26

### Remove Pistons and Connecting Rods

**NOTE:** Remove any carbon or ridge at the top of cylinder bores to prevent breaking rings when removing piston and connecting rod assemblies.

1. Remove #2 connecting rod cap.
2. Push connecting rod and piston assembly (11) out of #2 cylinder (arrow), **Fig. 27**. Reassemble cap to rod to prevent interchanging.
3. Repeat for #1 cylinder (10).

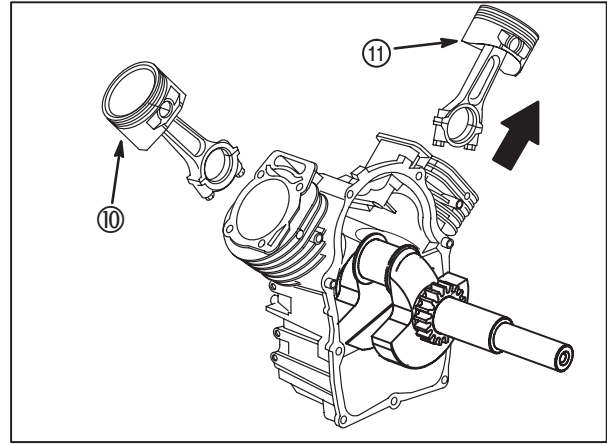


Fig. 27

### Remove Crankshaft

Remove crankshaft (1) from cylinder, **Fig. 28**.

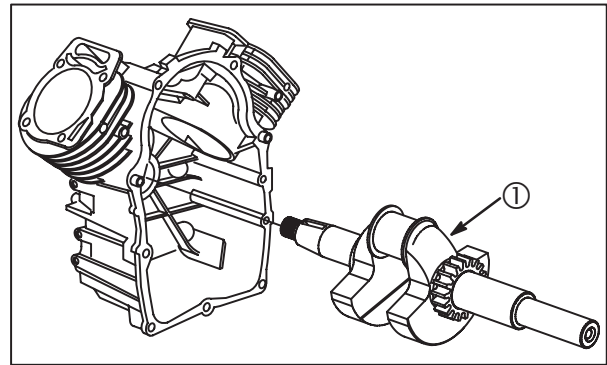


Fig. 28

### AFTER DISASSEMBLY

- Remove gasket material from ALL surfaces.
- Remove oil seals.
- Thoroughly clean parts in solvent.
- Organize all components. Keep parts that are assemblies together.

# Section 4

## Fuel Systems and Carburetion

---

	Page
<b>CARBURETION</b> .....	79
<b>Carburetor Identification</b> .....	79
<b>Carburetor Removal</b> .....	79
<b>Carburetor Service</b> .....	81
Aisan Carburetor – Models 290700, 303700, 350700 (after 950930xx) .....	81
Aisan Carburetor – Model 610000 .....	109
Mikuni Carburetor – Models 290700, 303700, 350700 (before 951001xx) .....	85
Mikuni Carburetor – Models 290400, 303400, 350400 (before 950801xx) .....	99
Nikki Carburetor – Models 290400, 303400, 350400 (after 950731xx) .....	94
Nikki Carburetor – Models 351700, 351400, 380700, 380400 .....	90
Nikki Carburetor – Model 540000 .....	104
<b>FUEL SYSTEMS</b> .....	76
<b>7-Quart Fuel Tank</b> .....	76
<b>9-Quart Fuel Tank</b> .....	77
<b>Fuel Pump</b> .....	78
<b>Fuel Filter</b> .....	79
<b>Fuel Shut-Off Valve</b> .....	79

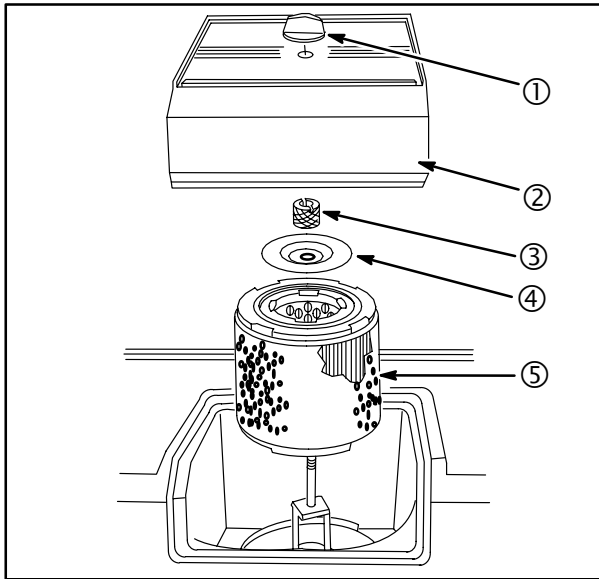
# FUEL SYSTEMS

## 7 Quart Fuel Tank

### Removal

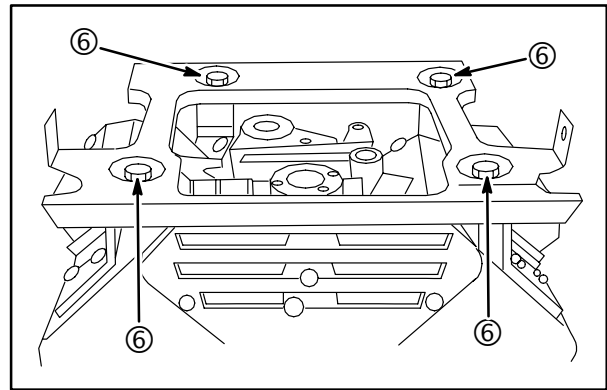
1. Remove air cleaner knob (1) and cover (2), **Fig. 1**.
2. Remove air cleaner nut (3), top plate (4) and element (5).

4



**Fig. 1**

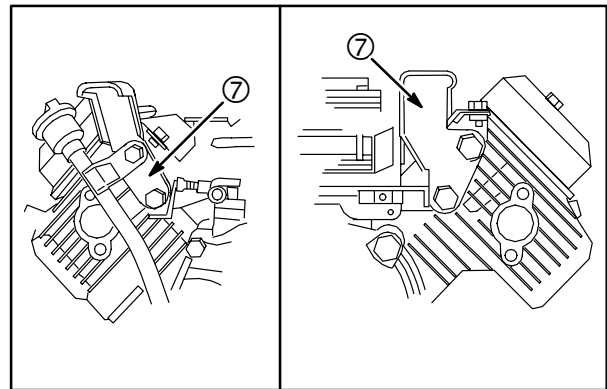
3. Turn the fuel shut-off to the OFF position. Disconnect fuel valve shut-off link.
4. Remove 2 screws (flywheel side) and 2 shoulder bolts (PTO side) from the fuel tank.
5. Lift the fuel tank. Disconnect the fuel line from the carburetor. Remove the fuel tank.
6. Remove air cleaner base. Disconnect the breather tube.
7. Remove 4 screws (6) and the fuel tank base plate, **Fig. 2**.



**Fig. 2**

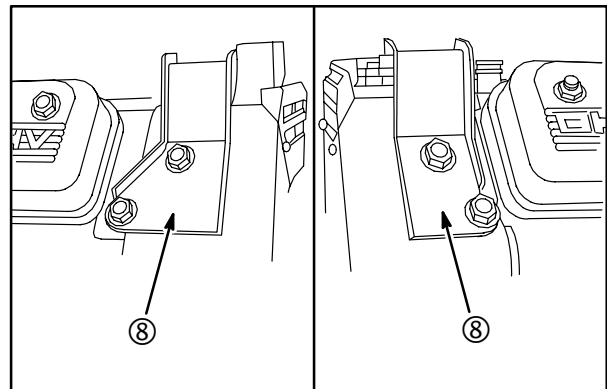
8. If necessary remove 4 screws and 2 PTO side fuel tank base supports (7), **Fig. 3**.

**NOTE:** Do not disturb the governor controls.



**Fig. 3**

9. If necessary remove 4 screws and 2 flywheel side fuel tank base supports (8), **Fig. 4**.



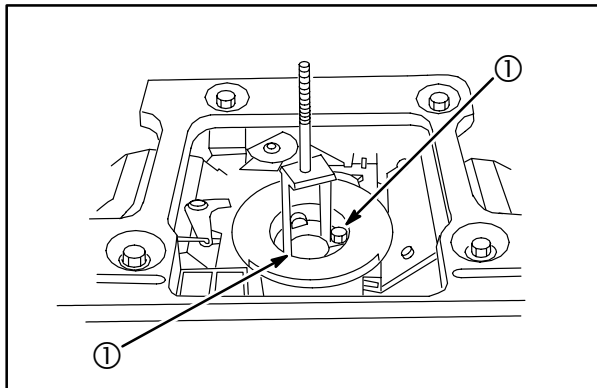
**Fig. 4**

### Installation

1. Install 2 flywheel side fuel tank base supports (8), **Fig. 4**. Torque screws to **140 in. lbs. (16 Nm)**.
2. Install 2 PTO side fuel tank base supports (7), **Fig. 3**. Torque screws to **140 in. lbs. (16 Nm)**.

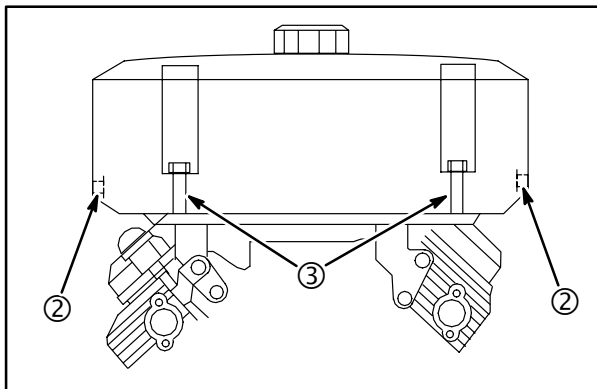
**NOTE:** Install the supports over the governor control bracket, one side at a time to avoid disturbing the governor adjustment. Install the screws in the same order as removed.

3. Install the fuel tank base plate. Torque screws to **140 in. lbs. (16 Nm)**.
4. Install the air cleaner base. Torque screws (1), **Fig. 5 to 60 in. lbs. (7 Nm)**. Connect the breather tube.



**Fig. 5**

5. Connect the fuel line to the carburetor. Install the fuel tank. Torque screws (2) and shoulder bolts (3) (PTO side) to **140 in. lbs. (16 Nm)**, **Fig. 6**.



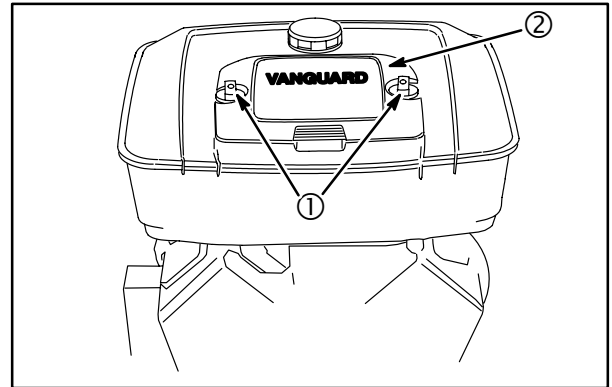
**Fig. 6**

6. Connect the fuel shut-off valve link. Slide the looped end of the link over the knob on the fuel valve. Tighten the screw securely.
7. Install the air cleaner element, top plate and nut.
8. Install the top cover plate and knob.

## 9 Quart Fuel Tank

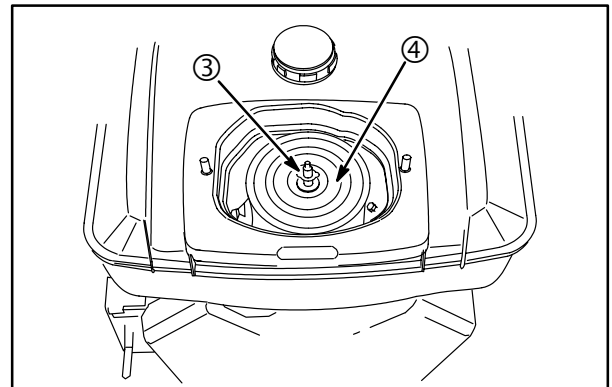
### Removal

1. Remove air cleaner cover knobs (1) and cover (2), **Fig. 7**.



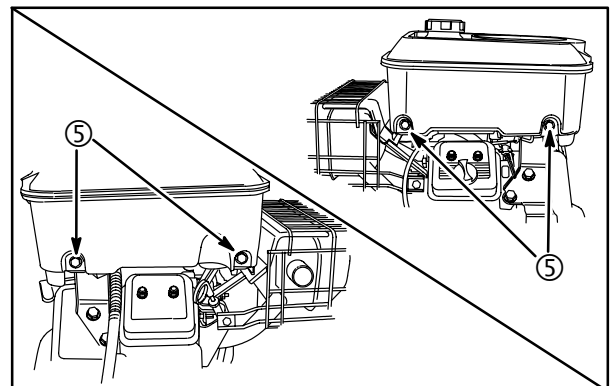
**Fig. 7**

2. Remove air cleaner nut (3), top plate (4) and air cleaner element, **Fig. 8**.



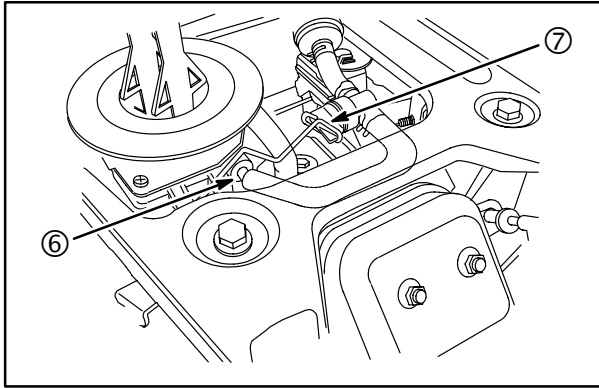
**Fig. 8**

3. Turn the fuel shut-off to the OFF position.
4. Remove 2 shoulder bolts (5) from each side of the fuel tank, **Fig. 9**.



**Fig. 9**

- Lift the fuel tank. Disconnect the fuel hose from the carburetor fuel inlet (6), **Fig. 10**. Remove the fuel valve shut-off knob from the shut-off link (7).



**Fig. 10**

- Remove the fuel tank.

### Installation

- Hold the fuel tank above the engine. Connect the fuel hose to the carburetor fuel inlet. Insert the fuel valve shut-off knob to the shut-off link.
- Put the fuel tank in position. Install 2 shoulder bolts to each side of the tank. Torque the shoulder bolts to **140 in. lbs. (16 Nm)**.
- Install the air cleaner element, top plate and nut.
- Install the air cleaner cover. Secure the cover with the air cleaner cover knobs.

## Fuel Pump

### General Information

**NOTE:** Some applications use an OEM supplied remote fuel pump. These engines are manufactured without a fuel pump.

The fuel pump allows for remote fuel tank installations. Fuel pressure is **1.5 psi (0.1 Bar)**. The pump will prime at **12" (30.5 cm)** maximum lift.

**CAUTION:** Excessive fuel pressure can result in an over-rich carburetor mixture and ultimately cylinder scoring and/or other engine damage, resulting from gasoline diluting the crankcase oil. **FUEL PUMP PRESSURE MUST NOT EXCEED 1.5 psi (0.1 Bar)**.

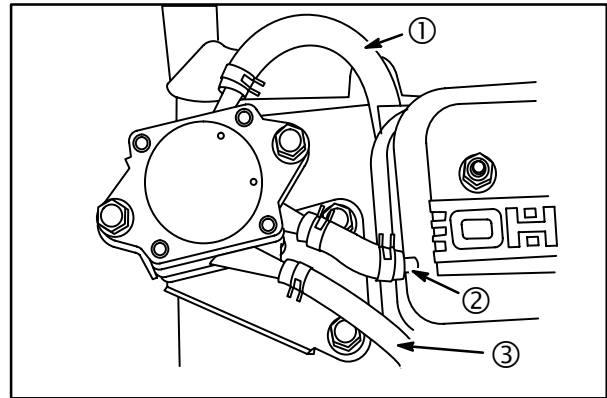
### All Except Models 540000, 610000

The fuel pump is actuated by pulsating crankcase vacuum from the engine. The vacuum pulse fitting (2), **Fig. 11** is installed on the No. 1 cylinder valve cover.

**NOTE:** A leak at the vacuum pulse hose or its connections will result in improper fuel flow.

Inspect the fuel hose from the fuel tank (3), the fuel hose to the carburetor (1) and the vacuum pulse hose. Replace any hose that is stiff or brittle.

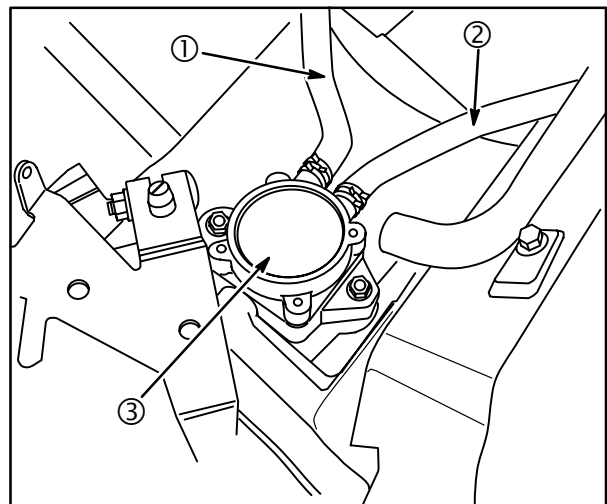
**NOTE:** The fuel pump is available only as an assembly.



**Fig. 11**

### Models 540000, 610000

The fuel pump (3), **Fig. 12**, is actuated by a lobe on the camshaft. Inspect the fuel hose (2) from the fuel tank to the pump and the hose from the pump to the carburetor (1). Replace fuel hoses if stiff or brittle.



**Fig. 12**

**NOTE:** Parts removed for clarity. The fuel pump is available only as an assembly.

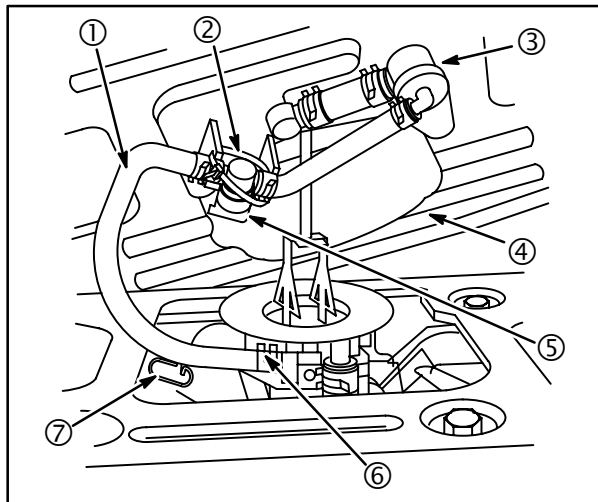
## Fuel Filter

Replace the inline fuel filter yearly or every 100 hours, whichever occurs first. Replace the filter if dirt or water are present. See the IPL for correct fuel filter.

Inspect the carburetor connection (6) and fuel shut-off valve (5) for leaks or damage, **Fig. 13**.

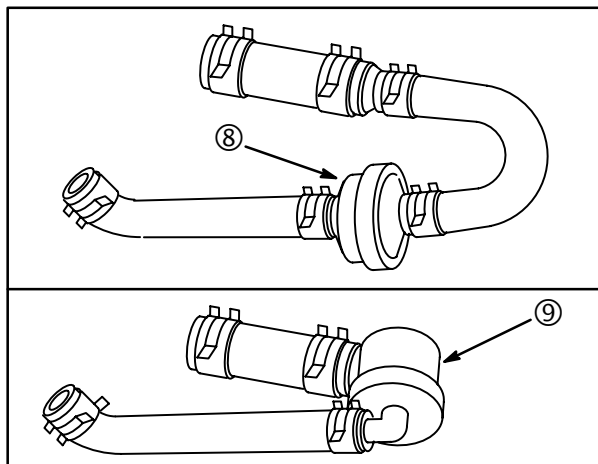
Inspect the tie wrap (2) securing the shut-off valve, replace as required.

- **CAUTION:** When replacing fuel filter (3) on Vanguard™ engines with the 9 quart fuel tank (4), the fuel hose from the carburetor (1) must be routed **OVER** the fuel shut-off rod (7) if engine is equipped with a Mikuni carburetor, or **UNDER** the fuel shut-off rod if engine is equipped with Nikki carburetor, **Fig. 13**.



**Fig. 13**

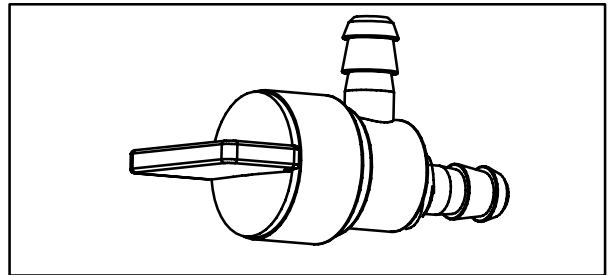
Early (8) and current (9) style fuel filter assemblies for Vanguard™ engines with the 9 quart fuel tank shown in **Fig. 14**.



**Fig. 14**

## Fuel Shut-Off Valve

Engines equipped with an optional fuel tank will also have a fuel shut-off valve, **Fig. 15**. Inspect valve for ease of operation and leakage. Replace valve if operation is difficult or if valve leaks.



**Fig. 15**

4

## CARBURETION

**NOTE:** Some Briggs & Stratton V-Twin engines operate on gaseous fuels. Information on the gaseous fueled engines is in Troubleshooting, Section 2.

**NOTE:** If the engine has an anti-afterfire solenoid, remove blower housing so the solenoid wire can be properly routed during reassembly. Disconnect anti-afterfire solenoid wire from equipment wire.

## Carburetor Identification

Three types of carburetors are used on gasoline Vanguard™ OHV V-Twin engines:

- One-piece Flo-Jet side-draft on **Models 290700, 294700, 303700, 350700, 351400, 351700, 380400 and 380700.**
- Two-piece Flo-Jet down-draft on **Models 290400, 303400 and 350400.**
- Fixed jet Flo-Jet side draft two barrel on **Models 540000, 610000.**

## Carburetor Removal

### Typical

Remove carburetor, spacer (3) and gaskets (2) from manifold (1), **Fig. 16**.

Discard gaskets.



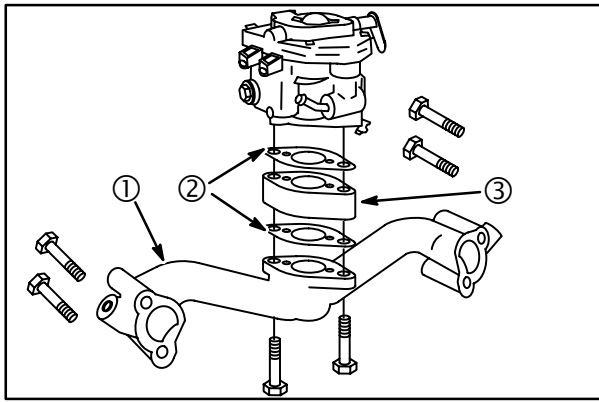


Fig. 16

### Models 351400 and 380400

The blower housing must be removed so that anti-afterfire solenoid wire can be properly routed during reassembly.

1. Disconnect fuel line at carburetor.
2. Remove anti-afterfire solenoid ground wire (5).
3. Remove choke control bracket (6) and disconnect link (4), **Fig. 17**.

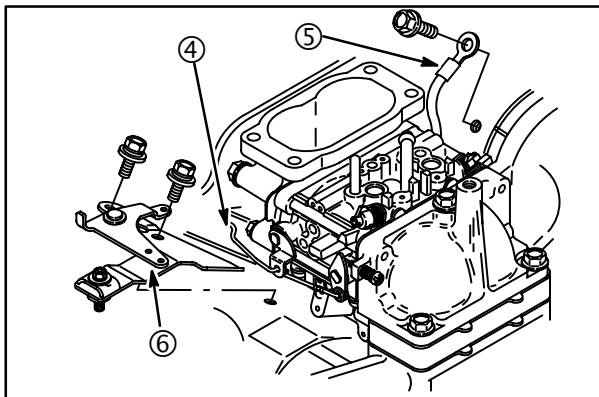


Fig. 17

4. Unhook governor link spring (7) from throttle lever. Disconnect governor link, **Fig. 18**.

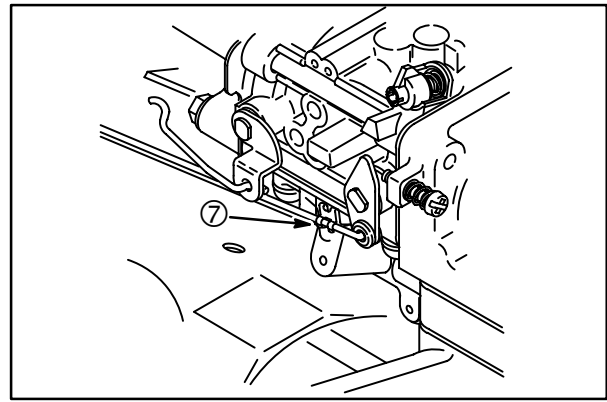


Fig. 18

5. Remove air cleaner elbow support screw (8), **Fig. 19**.
6. Remove 3 intake elbow screws and carburetor assembly.
7. Remove carburetor spacer (10) and gaskets (9).

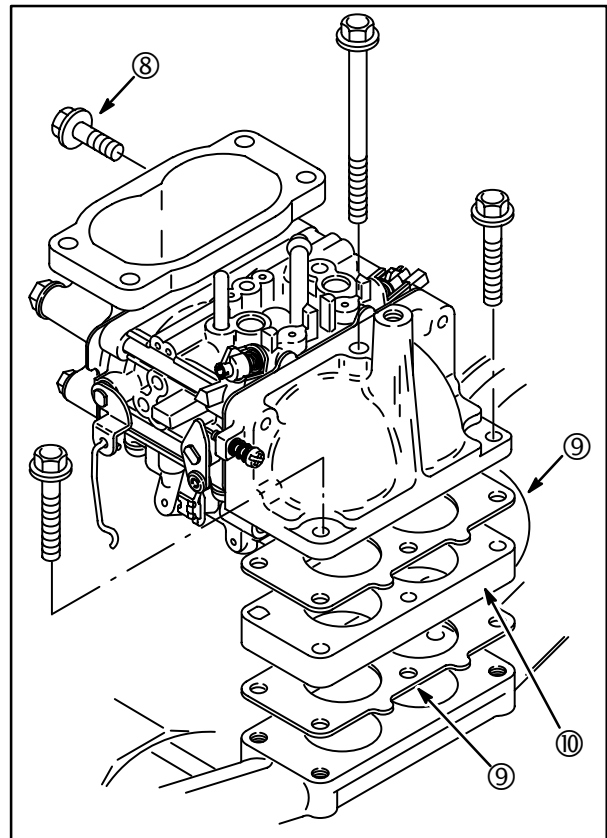


Fig. 19

8. Remove two nuts (13) and two screws (14). Separate air cleaner elbow (12) and intake elbow (15) from carburetor, **Fig. 20**.
9. Discard gaskets (11).

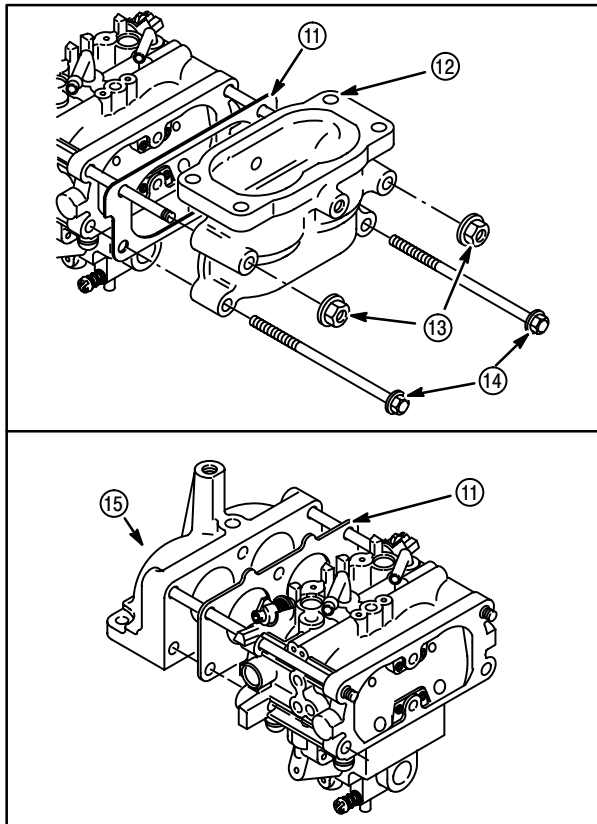


Fig. 20

## Carburetor Service

### Aisan Carburetor

**Models 290700, 303700, 350700**  
(After 950930xx)

#### Check Throttle, Choke Shaft and Body For Wear

**NOTE:** The measurement in Step 1 is taken with the carburetor off of the intake manifold.

1. Lay carburetor on flat surface and check throttle and choke shaft clearance (1) as shown, **Fig. 21**.

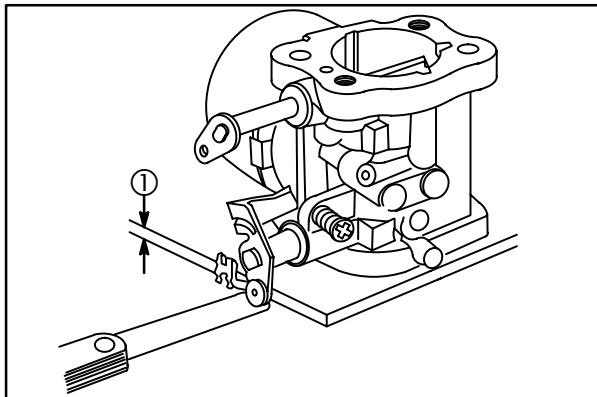


Fig. 21

Throttle shaft and choke shaft clearance must not exceed **0.010" (0.25 mm)**.

**NOTE:** The inspection in Step 2 is performed after the carburetor has been disassembled.

2. Inspect throttle shaft and choke shaft for wear (2), **Fig. 22**.

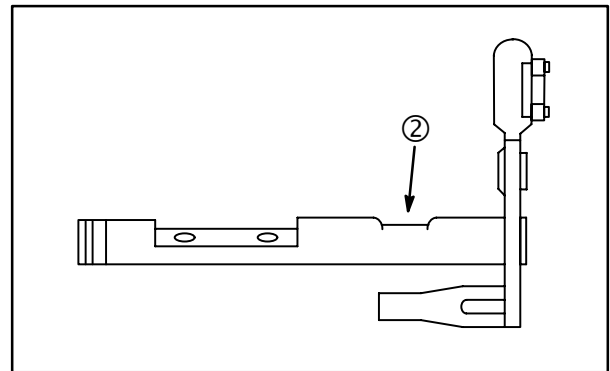


Fig. 22

Replace either shaft if worn.

Replace the carburetor if the body is worn or if either shaft clearance exceeds **0.010" (0.25 mm)** when a new shaft is used.

#### Disassemble

1. Remove anti-afterfire solenoid (1) or bowl screw (5) and washer (4), **Fig. 23**.
2. Remove float bowl (3). Discard bowl gasket (2).

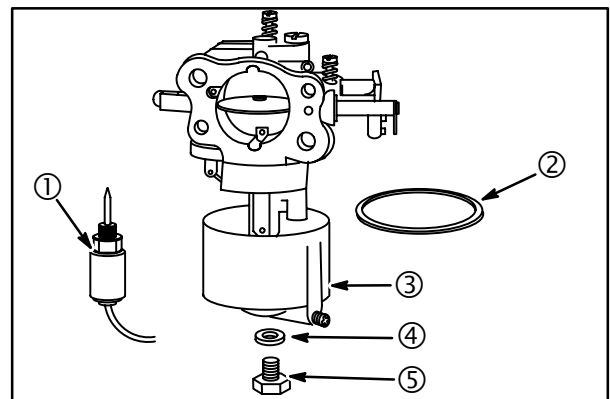


Fig. 23

3. Remove float hinge pin (6), float and inlet needle, **Fig. 24**.

**CAUTION:** Float hinge pin is a press fit. Use care when removing.

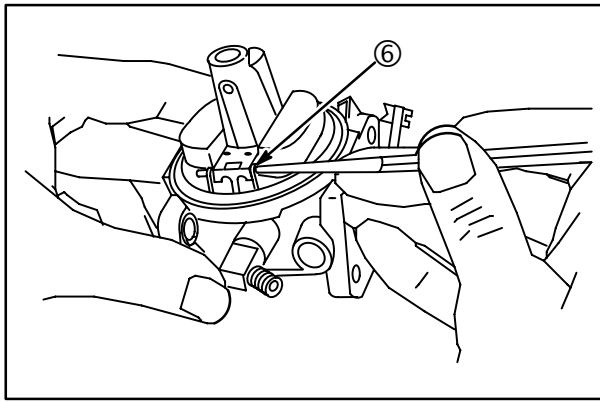


Fig. 24

4. Remove fixed main jet (7) using Screwdriver #19062, Fig. 25.
5. Reach into carburetor throat with flat blade screwdriver and push down on end of emulsion tube (8).

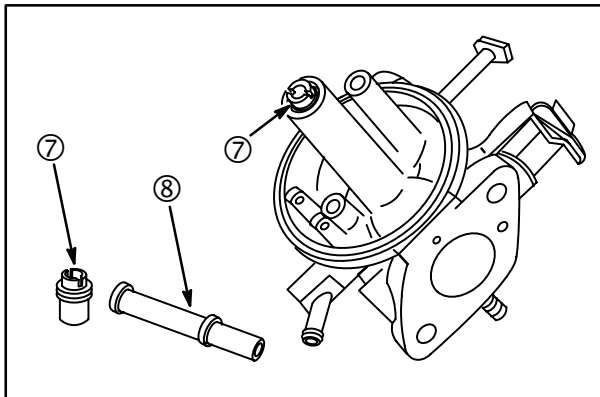


Fig. 25

**NOTE:** Consult the IPL to get the high altitude jet part number if required.

6. Remove idle jet plug (10) and idle jet (9), Fig. 26.

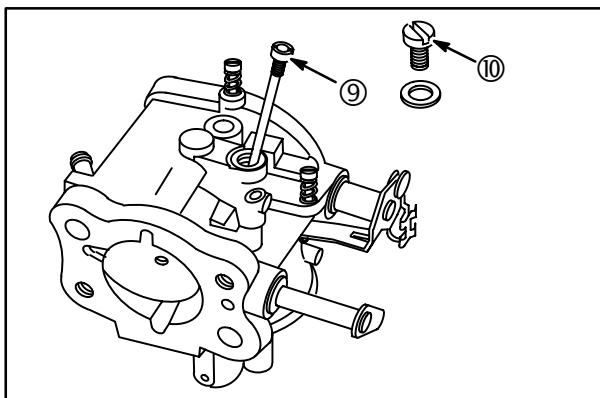


Fig. 26

7. Use a pliers to remove the idle mixture screw adjustment limiter cap (11) if equipped, Fig. 27.

8. Remove the idle mixture screw (12).

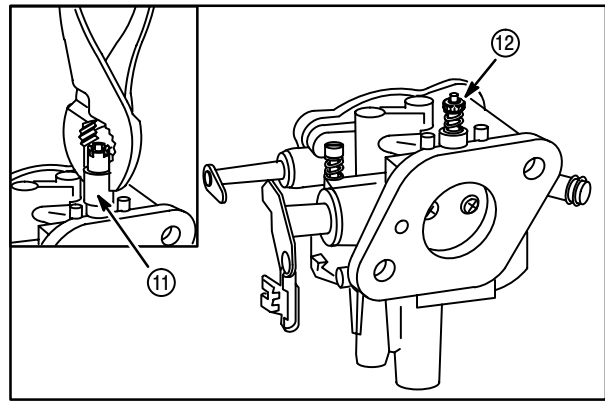


Fig. 27

9. The top and bottom edges of the throttle plate are beveled. Mark throttle plate (13) before removing to ensure reinstallation in the original position, Fig. 28.

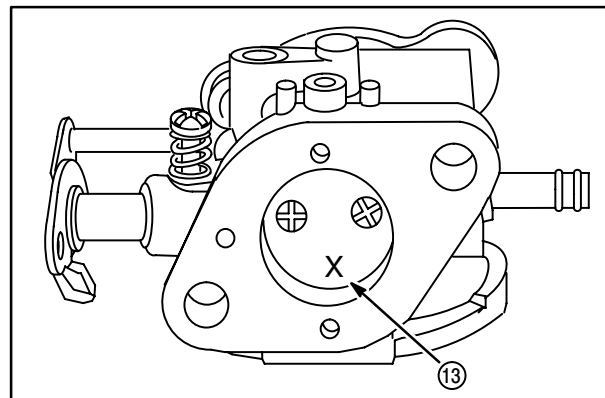


Fig. 28

10. Use a punch as shown and remove throttle shaft welch plug (14), Fig. 29.

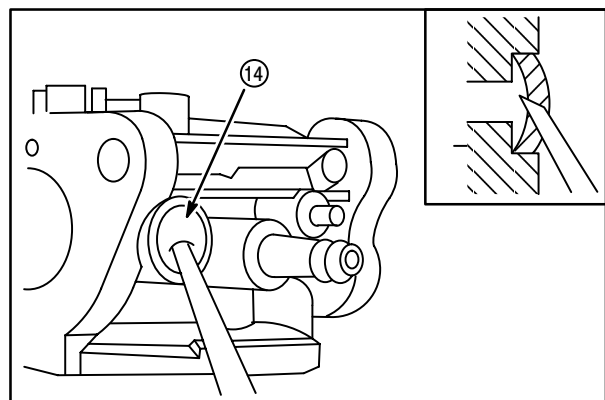


Fig. 29

11. Remove snap ring (16) and washer (15), Fig. 30.

12. Remove throttle shaft, collar (17) and seal (18).

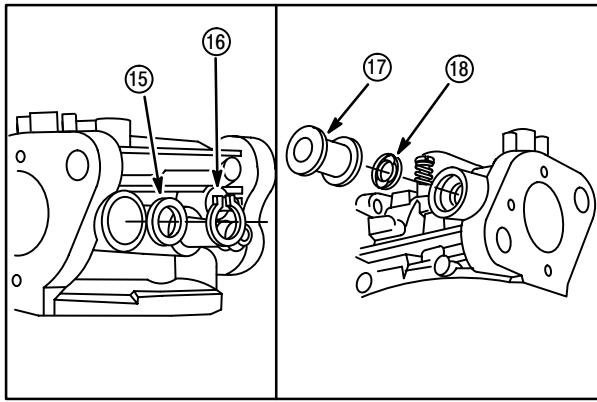




Fig. 30

13. Remove screw (25) and choke plate (24), Fig. 31.

	 <b>CAUTION</b>
	<b>AVOID EYE INJURY!</b>
<ul style="list-style-type: none"> <li>• Carburetor body has a detent ball (19) and spring (20) that keeps tension on choke shaft. Wear eye protection.</li> <li>• Use caution when removing shaft!</li> </ul>	

14. Remove E-ring (23), washer (22) choke shaft and seal (21).

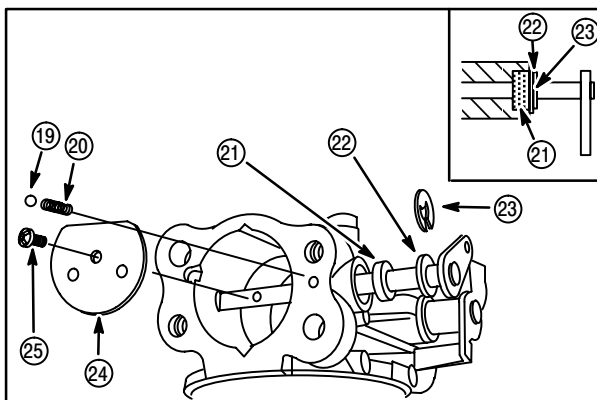


Fig. 31

15. Use a punch (26) to remove transitional hole welch plug (27) from top of carburetor, Fig. 32.

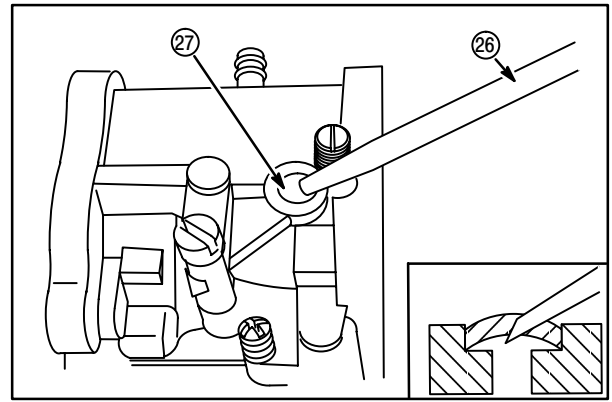




Fig. 32

This completes the carburetor disassembly procedure.



### Clean Carburetor

1. Disassemble carburetor.
2. Remove and discard all old gaskets, seals and sealing material.

	 <b>CAUTION</b>
	<b>AVOID INJURY!</b>
<ul style="list-style-type: none"> <li>• Wear suitable protection when using cleaners. Follow instructions on container.</li> </ul>	

3. Use commercial carburetor cleaning solvents (such as Briggs & Stratton Spray Cleaner, Part #100041 or #100042) to clean carburetor parts and body.
4. When cleaning non-metallic parts (plastic, nylon, Minlon™, etc.), do not leave in commercial carburetor cleaner more than 15 minutes.

**NOTE:** Parts containing rubber, such as seals, O-rings, inlet needles, seats or pump diaphragms should never be placed in commercial carburetor cleaner.

	 <b>CAUTION</b>
	<b>AVOID EYE INJURY!</b>
<ul style="list-style-type: none"> <li>• Wear eye protection whenever using compressed air to clean parts.</li> </ul>	

5. Use only compressed air (blowing in both directions) to clean out all openings and passages.

**NOTE:** Do not use wire, drills or other mechanical devices to clean out metering holes or passages.

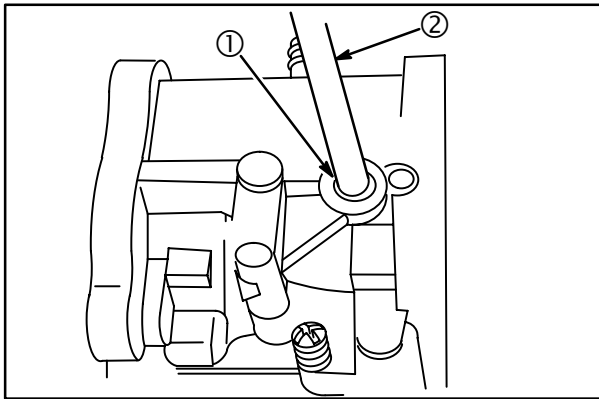
### Inspect Carburetor

Inspect all parts for wear, cracks, nicks and burrs. Inspect float for leaks. Replace damaged parts.

### Assemble

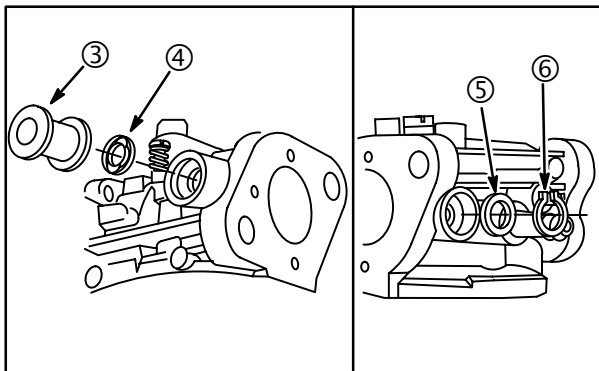
When assembling carburetor, use new seals and gaskets.

1. Install new transitional hole idle port welch plug (1), **Fig. 33**.
2. Use a round punch (2). Tap in plug until it is flat.
3. Seal the outside diameter of plug with Permatex® #2 or nail polish to prevent air leaks.



**Fig. 33**

4. Assemble new throttle shaft seal (4) with sealing lip out, **Fig. 34**.
5. Install throttle shaft with collar (3).
6. Install washer (5) and snap ring (6).

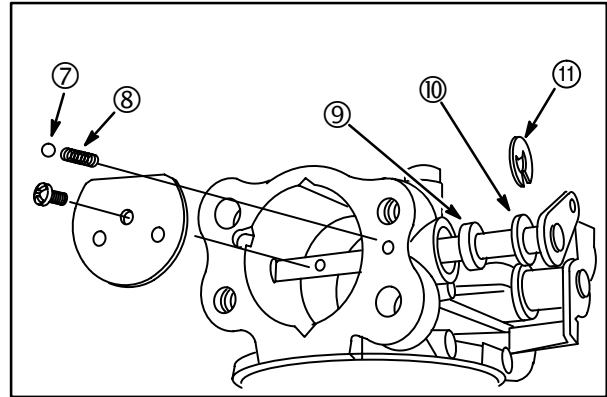


**Fig. 34**

7. Install throttle plate.

**NOTE:** Use LOCTITE® 222 on screw threads.

8. Install new throttle shaft welch plug. Use round punch and tap in plug until it is flat.
9. Use sealant on outside diameter of welch plug to prevent leaks.
10. Install new “E” ring (11), washer (10) and felt seal (9) onto choke shaft, **Fig. 35**.
11. Insert spring (8) and check ball (7) in to spring pocket. Compress with a small round punch.

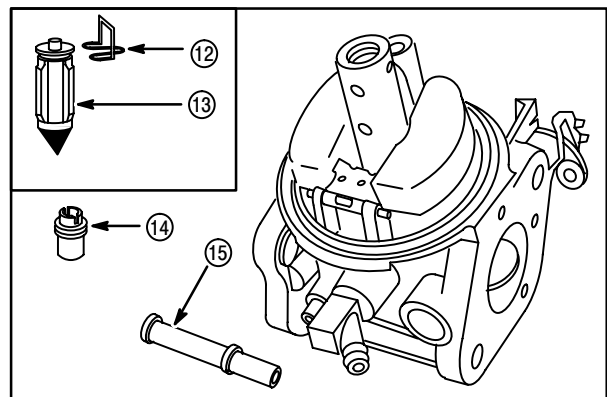


**Fig. 35**

12. Install choke shaft.
13. Install choke plate as shown, **Fig. 35**.

**NOTE:** Use LOCTITE® 222 on screw threads.

14. Assemble inlet needle retainer (12) to inlet needle (13). Assemble to float, **Fig. 36**.
15. Install float.
16. Install emulsion tube (15) and fixed main jet (14).



**Fig. 36**

17. Check float adjustment, **Fig. 37**.
  - a. Hold carburetor in vertical position with float hinge up as shown.
  - b. Float should be parallel (17) to bowl mounting surface.
  - c. Bend tang (16) if required.

**NOTE:** DO NOT press on float to adjust.

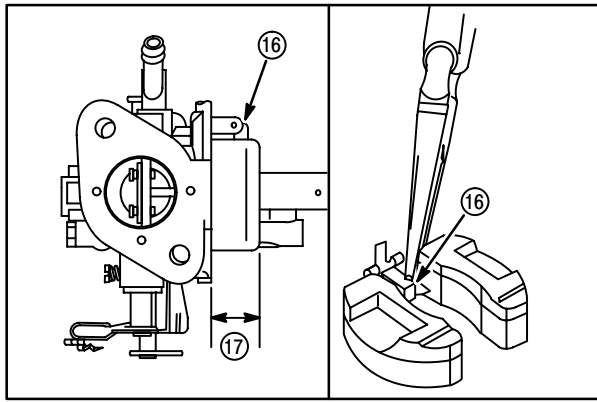


Fig. 37

18. Install idle jet (18), plug (19) and gasket (20), Fig. 38.

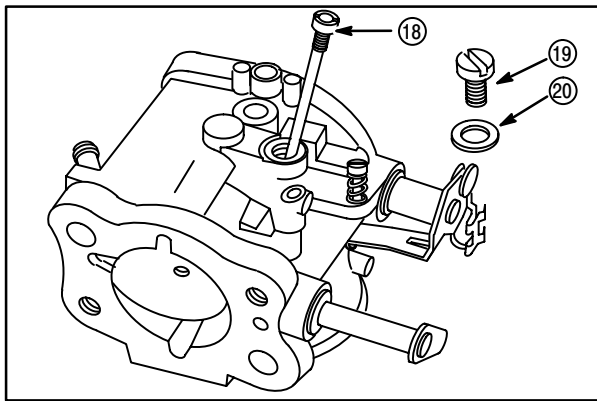


Fig. 38

19. Install idle mixture screw (21) and spring (22), Fig. 39.

**NOTE:** DO NOT tighten screw. DO NOT install the limiter cap at this time.

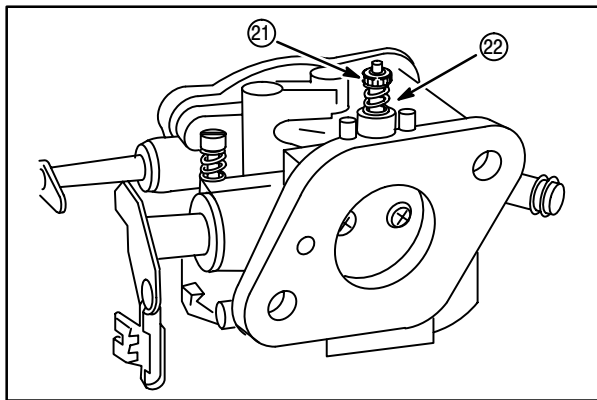


Fig. 39

20. Install bowl gasket (24), float bowl (25), washer (26) and screw (27) or anti-afterfire solenoid (23), if equipped, Fig. 40.

21. Position bowl drain as shown.

22. Torque screw or solenoid to **45 in. lbs. (5 Nm)**.

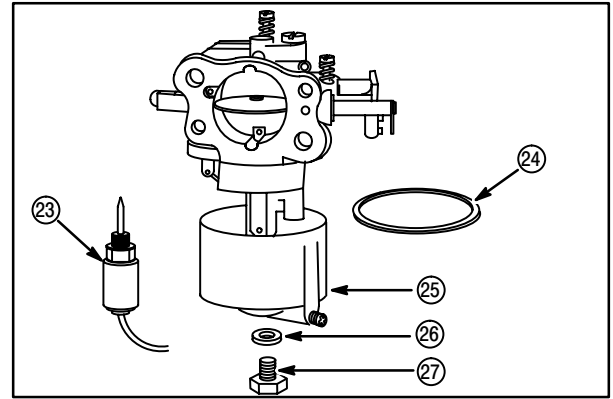


Fig. 40

### Mikuni Carburetor

**Models 290700, 303700, 350700 (Before 951001xx)**

### Check Throttle, Choke Shaft and Body For Wear

**NOTE:** The measurement in Step 1 is taken with the carburetor off of the intake manifold.

1. Lay carburetor on flat surface. Use a feeler gauge (1) to check throttle and choke shaft clearance as shown in Fig. 41.

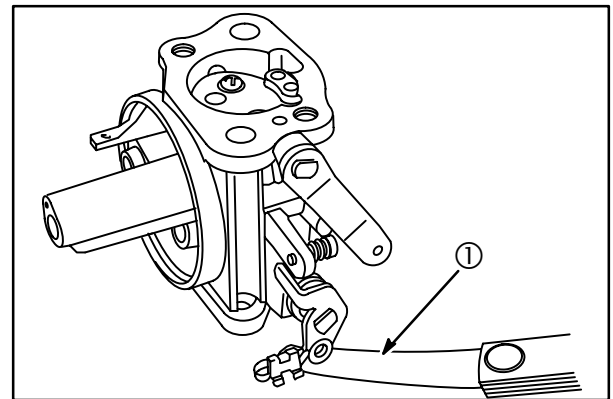


Fig. 41

Throttle shaft and choke shaft clearance must not exceed **0.010" (0.25 mm)**.

**NOTE:** The inspection in Step 2 is performed after the carburetor has been disassembled.

2. Inspect throttle shaft and choke shaft for wear (2), Fig. 42.

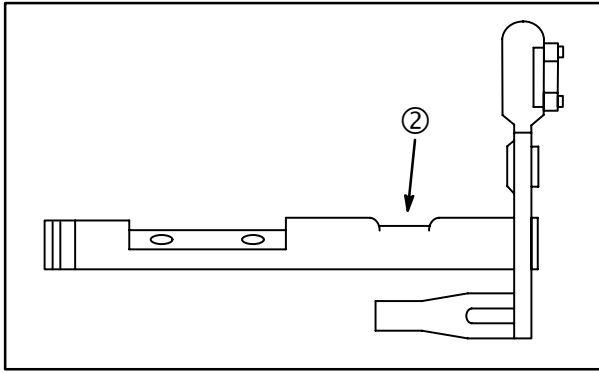


Fig. 42

4

Replace either shaft if worn.

Replace the carburetor if the body is worn or if either shaft clearance exceeds **0.010" (0.25 mm)** when a new shaft is used.

**Disassemble**

1. Remove anti-afterfire solenoid (2) or bowl screw (1), washer and bowl (3), **Fig. 43**. Remove bowl gasket (4).

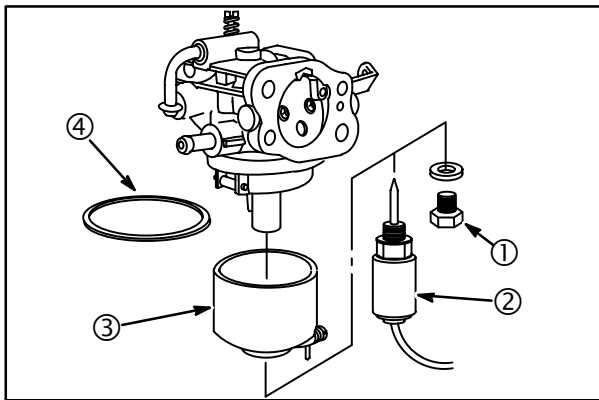


Fig. 43

2. Remove fixed main jet (7) using Screwdriver #19061, **Fig. 44**.
3. Remove float (5) and inlet needle (6).

**NOTE:** Float hinge pin (8) is swaged on one end. Drive hinge pin out from side opposite swage.

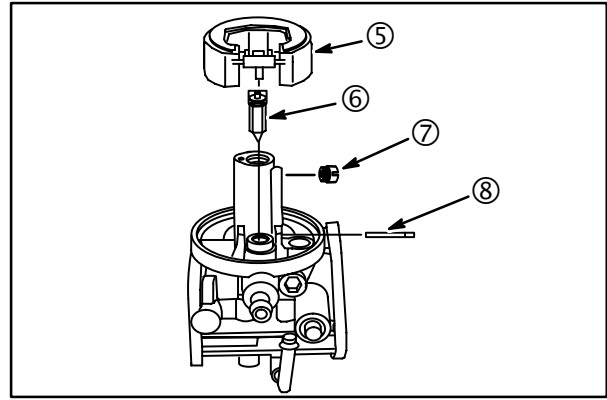


Fig. 44

4. Remove emulsion tube (10), **Fig. 45**.

**NOTE:** If carburetor is equipped with solenoid, remove solenoid seat (9) first, then remove emulsion tube.

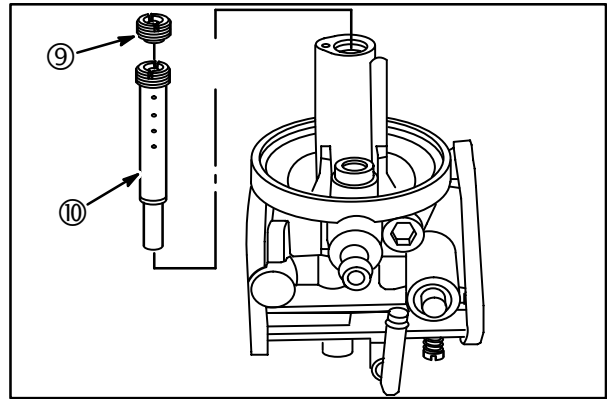


Fig. 45

5. Use a pliers to remove the idle mixture screw adjustment limiter cap (14) if equipped, **Fig. 46**.
6. Remove idle mixture screw (11) and spring (12).
7. Remove pilot jet (13).

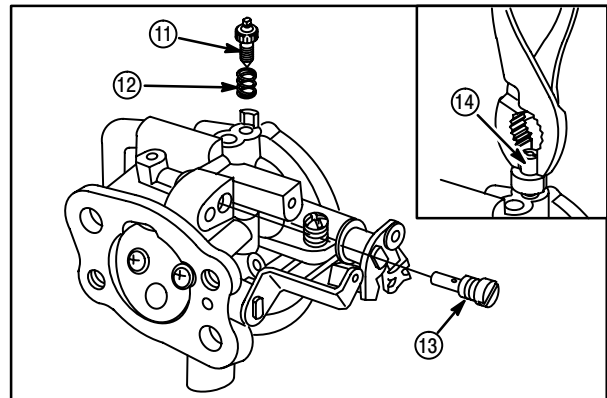
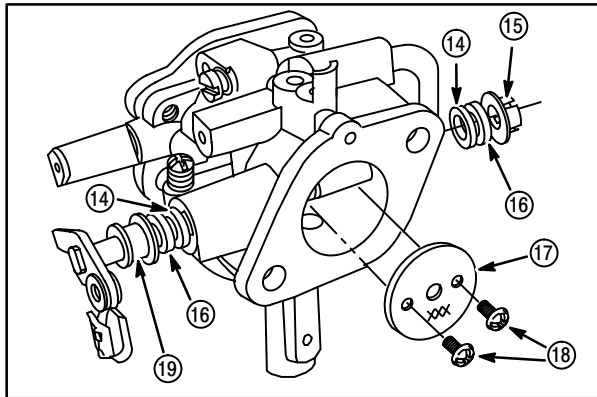


Fig. 46

8. Remove two screws (18) and the throttle plate (17), **Fig. 47**.

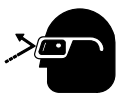

**NOTE:** The top and bottom edges of the throttle plate are beveled. Mark throttle plate before removing to ensure reinstallation in the original position.

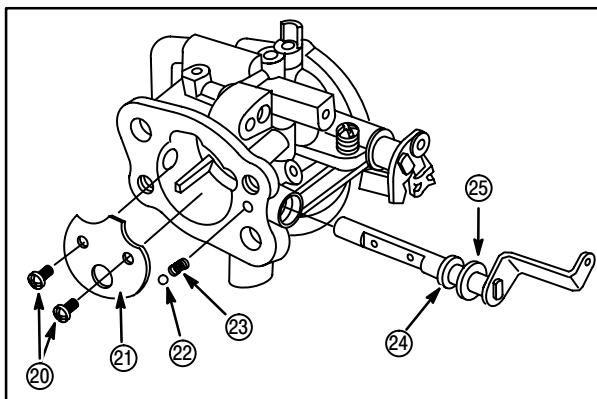
9. Remove retainer (15).
10. Remove throttle shaft and spacer (19).
11. Remove seals (14) and foam seals (16).



**Fig. 47**

12. Remove two screws (20), choke plate (21), shaft, seal (24) and washer (25), **Fig. 48**.

	 <p><b>CAUTION</b></p> <p><b>AVOID EYE INJURY!</b></p>
<ul style="list-style-type: none"> <li>• Carburetor body has a detent ball (22) and spring (23) that keeps tension on choke shaft. Wear eye protection.</li> <li>• Use caution when removing shaft!</li> </ul>	

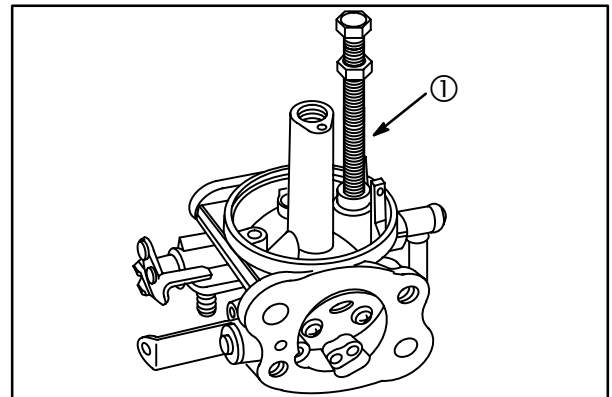


**Fig. 48**

### **Remove Fuel Inlet Body and Seat**

The fuel inlet body must be removed before the inlet seat can be removed.

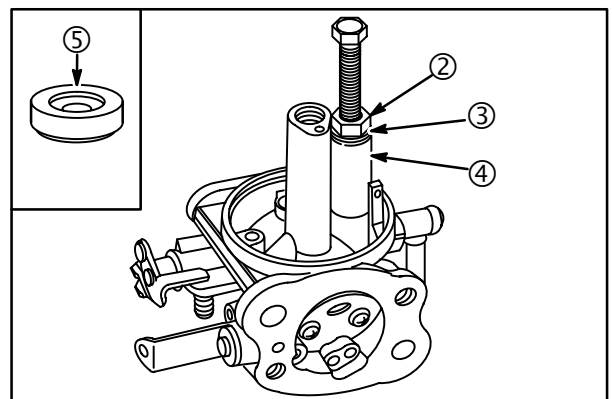
1. Use Screw #93029 (1) from Flywheel Puller, #19165. Thread screw into seat body 3 - 4 turns, **Fig. 49**. Remove the screw from the seat body.



**Fig. 49**

2. Install 1/4" x 20 Nut #92278 (2) and Washer #224061 (3) from #19332 Tool Kit onto screw, **Fig. 50**.
3. Place a 1/4" drive 9 mm (3/8") socket (4) over seat body.
4. Install screw, washer and nut. Thread nut down on washer.
5. Continue turning until seat body is removed. Remove fuel inlet seat (5).

This completes the carburetor disassembly procedure.

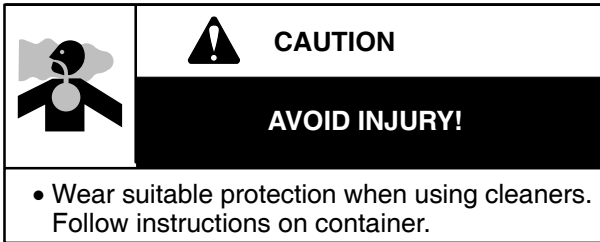


**Fig. 50**



### Clean Carburetor

1. Disassemble carburetor.
2. Remove and discard all old gaskets, seals and sealing material.



4

3. Use a commercial carburetor cleaner (such as Briggs & Stratton Spray Cleaner #100041 or #100042) to clean carburetor parts and body.
4. When cleaning non-metallic parts (plastic, nylon, Minlon™, etc.), do not leave in commercial carburetor cleaner more than 15 minutes.

**NOTE:** Do not use commercial carburetor cleaners on parts containing rubber, such as seals, O-rings, inlet needles, seats or pump diaphragms.



5. Use only compressed air (blowing in both directions) to clean out all openings and passages.

**NOTE:** Do not use wire, drills or other mechanical devices to clean out metering holes or passages.

### Inspect Carburetor

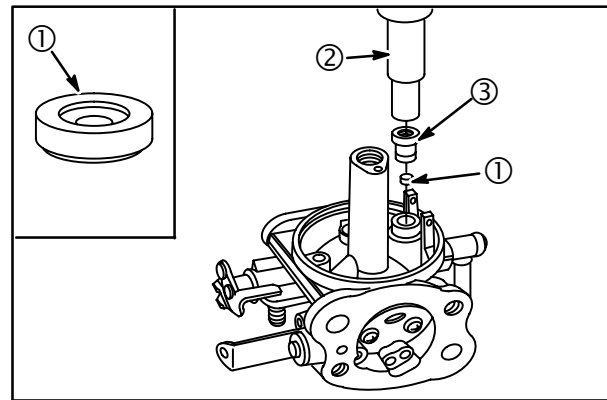
Inspect all parts for wear, cracks, nicks and burrs. Inspect float for leaks. Replace damaged parts.

### Assemble Carburetor

When assembling carburetor, use new seals and gaskets.

### Install Fuel Inlet Seat and Body

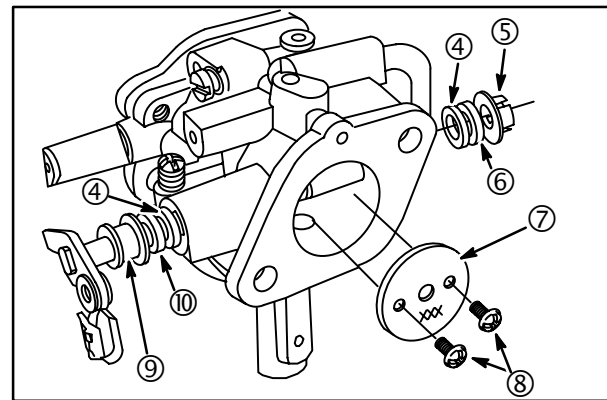
1. Install new inlet seat (1) with chamfered end down, **Fig. 51**.
2. Press in new body (3) using Knockout Pin #19135 (2).



**Fig. 51**

3. Install new throttle shaft seals (4) with sealing lip out, **Fig. 52**.
4. Install throttle shaft with foam seal (10) and spacer (9).
5. Install foam seal (6) and retainer (5).
6. Install throttle plate (7) with numbers down.

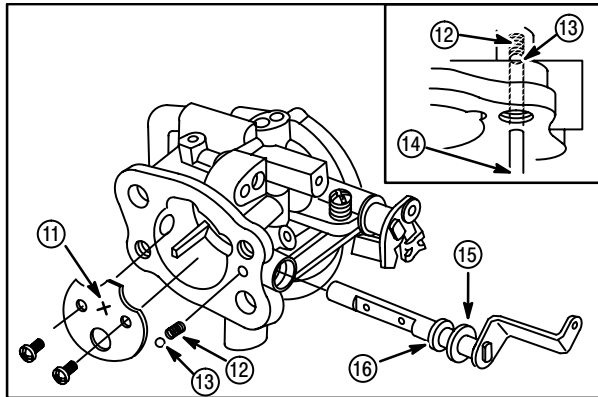
**NOTE:** Use LOCTITE® 222 on screw (8) threads.



**Fig. 52**

7. Install new choke shaft seal (16) with sealing lip out, **Fig. 53**.
8. Assemble washer (15) onto choke shaft.
9. Insert spring (12) and check ball (13) in to spring pocket. Compress with a small round punch (14).
10. Push choke shaft into hole until ball engages groove in choke shaft, **inset, Fig. 53**.
11. Install choke plate (11) as shown.

**NOTE:** Use LOCTITE® 222 on screw threads.

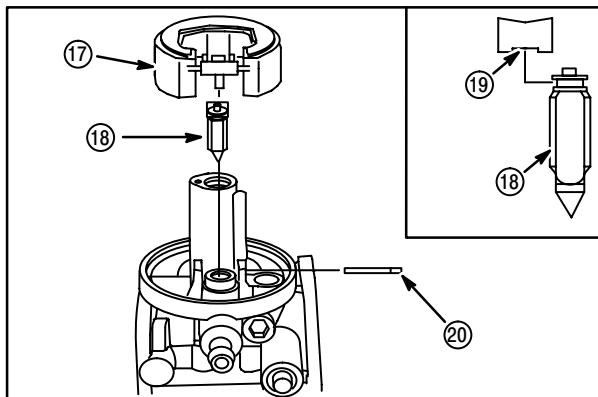


**Fig. 53**

12. Assemble inlet needle retainer (19) to inlet needle (18). Assemble to float (17), **Fig. 54**.

13. Install float to carburetor body. Install float hinge pin (20) with swaged end out.

**NOTE:** Float level is not adjustable.

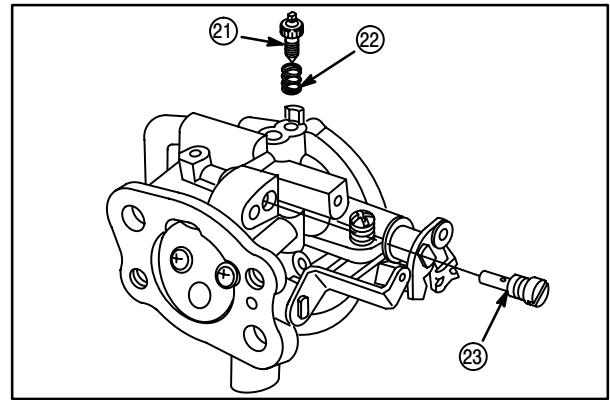


**Fig. 54**

14. Install pilot jet (23), **Fig. 55**.

15. Install idle mixture screw (21) and spring (22).

**NOTE:** DO NOT tighten screw. DO NOT install limiter cap at this time.

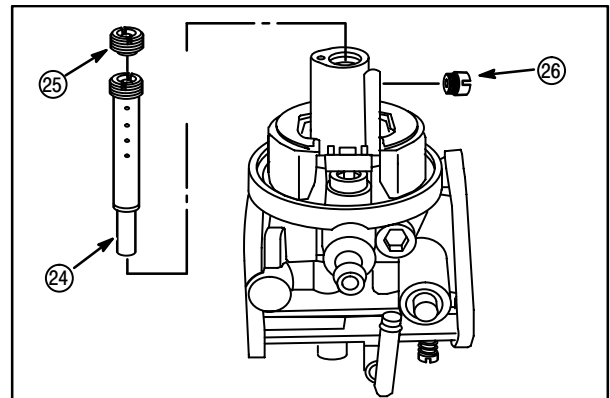


**Fig. 55**

16. Install emulsion tube (24), **Fig. 56**, using Screwdriver #19062.

17. If carburetor is equipped with anti-afterfire solenoid, install solenoid seat (25).

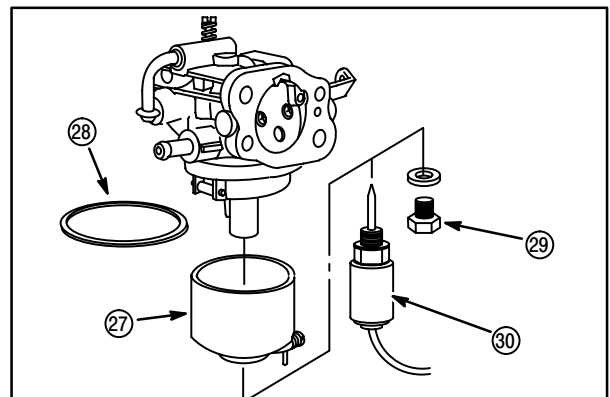
18. Install fixed main jet (26) using Screwdriver #19061.



**Fig. 56**

19. Install bowl gasket (28), float bowl (27), washer and screw (29) or anti-afterfire solenoid (30), if equipped, **Fig. 57**.

20. Position bowl drain as shown. Torque screw or solenoid to **45 in. lbs. (5 Nm)**.



**Fig. 57**

## Nikki Carburetor

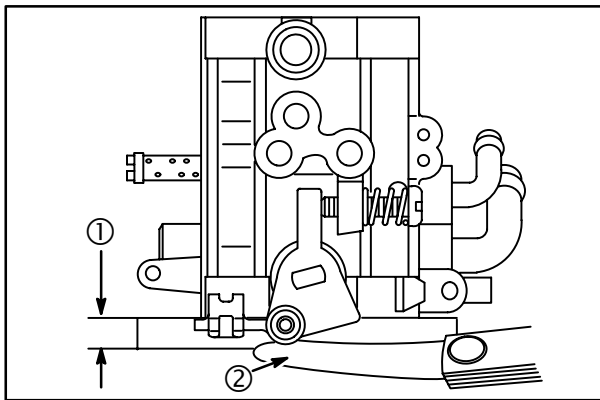
**Models 351700, 351400, 380700, 380400**

### Check Throttle, Choke Shaft and Body For Wear

**NOTE:** The measurement in Step 1 is taken with the carburetor off of the intake manifold.

1. Lay carburetor on 1/4" (6.35 mm) raised flat surface (1). Check throttle and choke shaft clearance with a feeler gauge (2) as shown in **Fig. 58**.

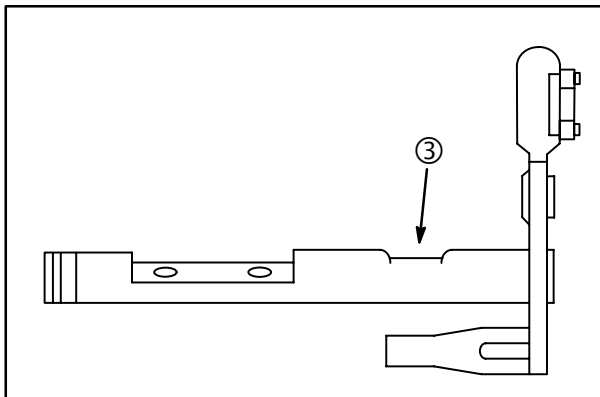
Throttle shaft and choke shaft clearance must not exceed **0.010" (0.25 mm)**.



**Fig. 58**

**NOTE:** The inspection in Step 2 is performed after the carburetor has been disassembled.

2. Inspect throttle shaft and choke shaft for wear (3). Replace if worn, **Fig. 59**.



**Fig. 59**

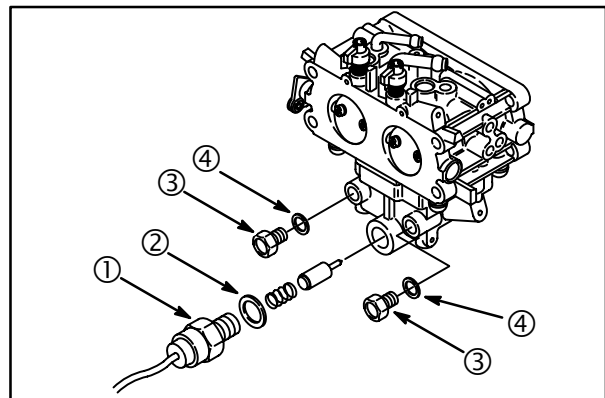
Replace either shaft if worn.

Replace the carburetor of the body is worn or if either shaft clearance exceeds **0.010" (0.25 mm)** when a new shaft is used.

### Disassemble

**NOTE:** The carburetors used on vertical crankshaft Models 351700 and 380700, and horizontal crankshaft Models 351400 and 380400 are similar enough that the disassembly and reassembly procedures can be considered the same. The only significant differences in the carburetors are the location of the idle mixture screws and the fixed main jet orifice sizes.

1. Remove anti-afterfire solenoid (1) with washer (2), **Fig. 60**.
2. Remove fixed main jet plugs (3) with washers (4).



**Fig. 60**

3. Remove fixed main jets (7, 8), **Fig. 61**.

**NOTE:** The carburetor is equipped with a different size fixed main jet for each cylinder. The carburetor is marked **L** (6) for the #1 cylinder and **R** (5) for the #2 cylinder.

The carburetor is marked in the upper body near the choke plate and the lower body near the main jet plugs. See **Fig. 61**.

## Fixed Main Jet Sizes

### Model 351700

Left (#1) cylinder is equipped with **#98** main jet.  
Right (#2) cylinder is equipped with **#100** main jet.

### Model 351400

Left (#1) cylinder is equipped with **#94** main jet.  
Right (#2) cylinder is equipped with **#98** main jet.

### Model 380700

Left (#1) cylinder is equipped with **#118** main jet.  
Right (#2) cylinder is equipped with **#116** main jet.

### Model 380400

Left (#1) cylinder is equipped with **#110** main jet.  
Right (#2) cylinder is equipped with **#114** main jet.

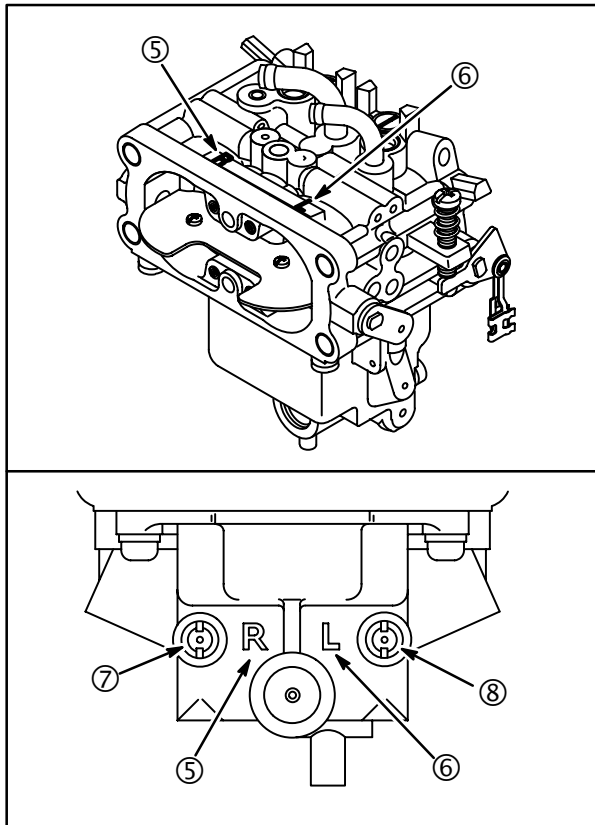


Fig. 61

- Remove carburetor lower body screws (9). Lift lower body straight away from upper body, **Fig. 62**. Discard gasket (10).

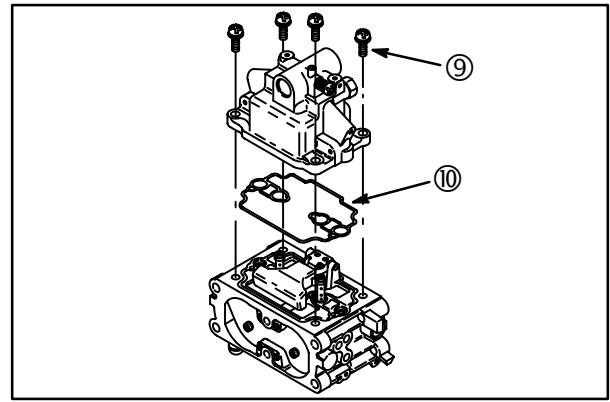


Fig. 62

- Remove pilot jets (11), **Fig. 63**.
- Remove float bowl drain screw (13) and spring (12).

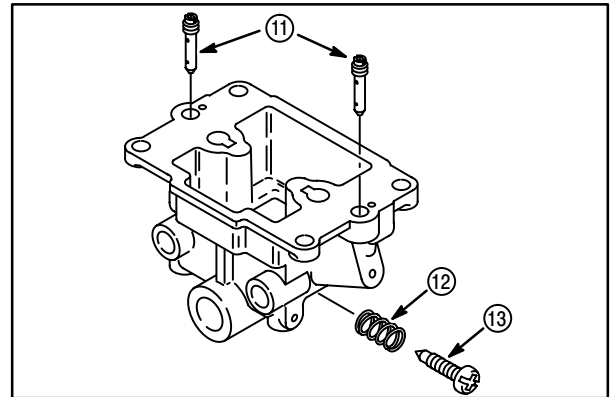


Fig. 63

- Drive out float hinge pin (16) from side **OPPOSITE** throttle lever (17). Remove float (14) and fuel inlet needle (15) assembly, **Fig. 64**.
- Remove and discard throttle shaft and choke shaft welch plugs.

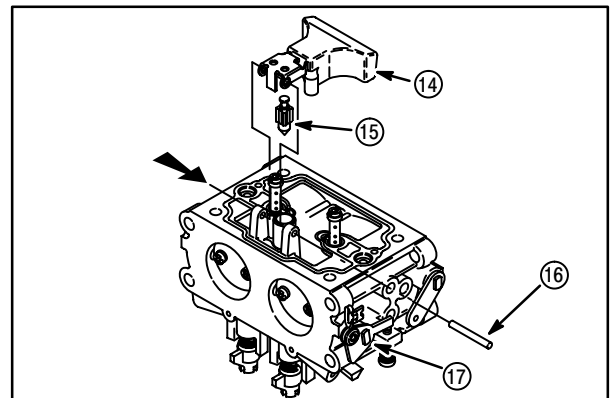


Fig. 64

- Remove idle mixture screws (19) and springs (20), **Fig. 65**.

**NOTE:** If idle mixture screws are equipped with adjustment limiter caps, remove the caps (18) BEFORE removing idle mixture screws, inset, Fig. 65.

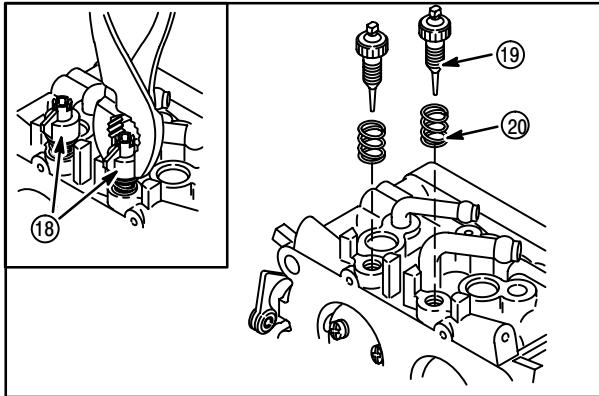


Fig. 65

10. Mark throttle plates (24) before removing to ensure reinstallation in the original position, Fig. 66.

11. Remove throttle shaft (22), spacer (21) and seal (23).

**NOTE:** Do not remove throttle shaft welch plug.

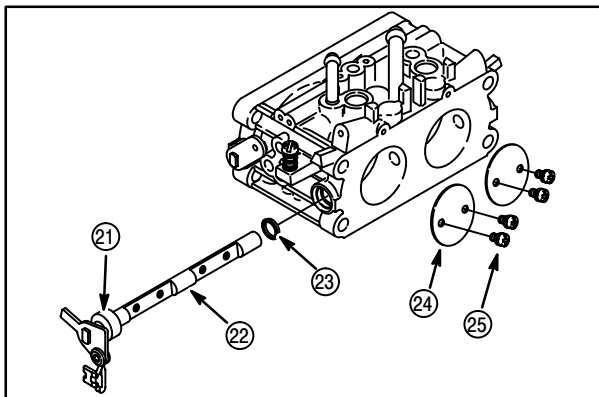


Fig. 66

12. Mark choke plate (26) before removing to ensure reinstallation in the original position, Fig. 67.

13. Remove choke shaft (27) and seal (28).

This completes the carburetor disassembly procedure.

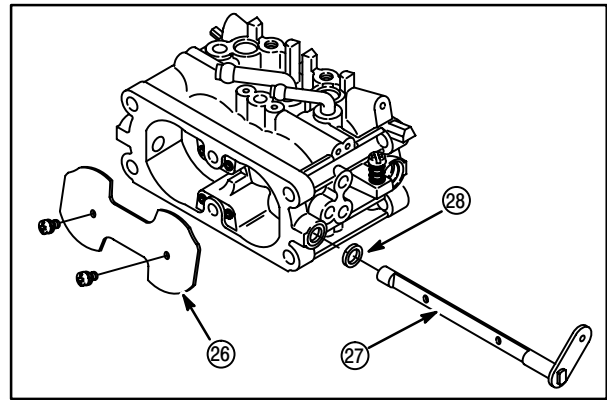




Fig. 67

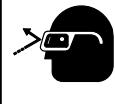

### Clean Carburetor

1. Disassemble carburetor.
2. Remove and discard all old gaskets, seals and sealing material.

	 <b>CAUTION</b>
	<b>AVOID INJURY!</b>
<ul style="list-style-type: none"> <li>• Wear suitable protection when using cleaners. Follow instructions on container.</li> </ul>	

3. Use a commercial carburetor cleaner (such as Briggs & Stratton Spray Cleaner, Part #100041 or #100042) to clean carburetor parts and body.
4. When cleaning non-metallic parts (plastic, nylon, Minlon™, etc.), do not leave in commercial carburetor cleaner more than 15 minutes.

**NOTE:** Do not use commercial carburetor cleaners on parts containing rubber, such as seals, O-rings, inlet needles, seats or pump diaphragms.

	 <b>CAUTION</b>
	<b>AVOID EYE INJURY!</b>
<ul style="list-style-type: none"> <li>• Wear eye protection whenever using compressed air to clean parts.</li> </ul>	

5. Use only compressed air (blowing in both directions) to clean out all openings and passages.

**NOTE:** Do not use wire, drills or other mechanical devices to clean out metering holes or passages.

### Inspect Carburetor

Inspect all parts for wear, cracks, nicks and burrs. Inspect float for leaks. Replace damaged parts.

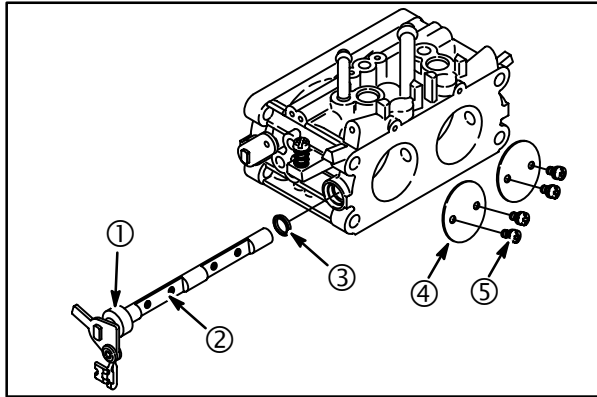
### Assemble Carburetor

When assembling carburetor, use new seals and gaskets.

1. Install new throttle shaft seal (3) with sealing lip out, **Fig. 68**.
2. Install throttle shaft (2) with spacer (1).

**NOTE:** Install one throttle plate (4) at a time. Check throttle shaft for freedom of operation after installing each throttle plate.

**NOTE:** Use LOCTITE® 222 on screw threads (5).

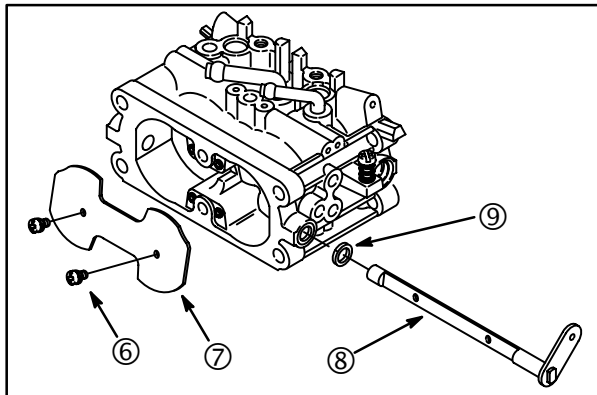


**Fig. 68**

3. Install new choke shaft seal (9), **Fig. 69** with sealing lip out.
4. Install choke shaft (8).
5. Install choke plate (7).

**NOTE:** Check shaft for freedom of operation after installing plate.

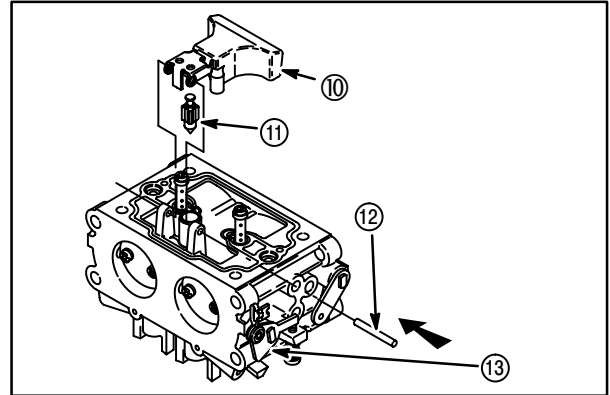
**NOTE:** Use LOCTITE® 222 on screw threads (6).



**Fig. 69**

6. Assemble inlet needle (11) to float (10). Install float assembly to carburetor body, **Fig. 70**. Install float hinge pin (12) from throttle lever (13) side.

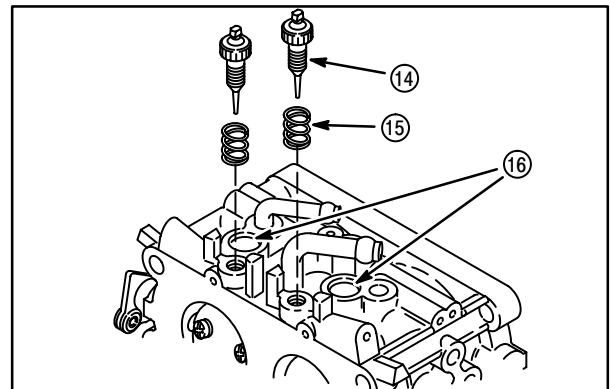
**NOTE:** Be sure float hinge pin is flush with float support or hinge pin will interfere with lower body.



**Fig. 70**

7. Install new welch plugs (16) with 5/16" (8 mm) punch, **Fig. 71**.
8. Use a sealant such as Permatex® #2 or nail polish on outside diameter of plug to prevent air leaks.
9. Install idle mixture screws (14) and springs (15).

**NOTE:** DO NOT tighten screws. DO NOT install limiter caps at this time.



**Fig. 71**

10. Install pilot jets (17), **Fig. 72**.
11. Install fuel bowl drain screw (19) and spring (18).

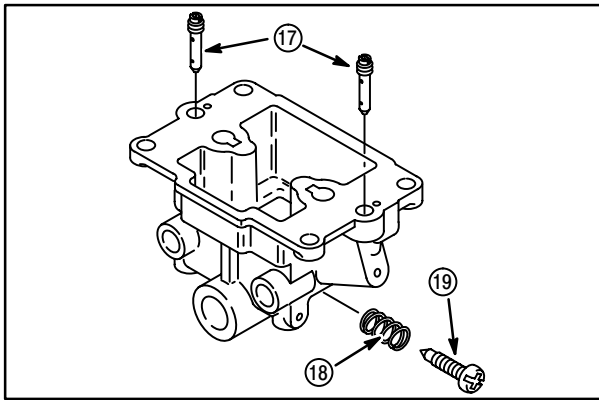


Fig. 72

12. Install fixed main jets (20), **Fig. 73**, plugs and washers.

#### Model 351700

Left (#1) cylinder is equipped with #98 main jet.  
Right (#2) cylinder is equipped with #100 main jet.

#### Model 351400

Left (#1) cylinder is equipped with #94 main jet.  
Right (#2) cylinder is equipped with #98 main jet.

#### Model 380700

Left (#1) cylinder is equipped with #118 main jet.  
Right (#2) cylinder is equipped with #116 main jet.

#### Model 380400

Left (#1) cylinder is equipped with #112 main jet.  
Right (#2) cylinder is equipped with #114 main jet.

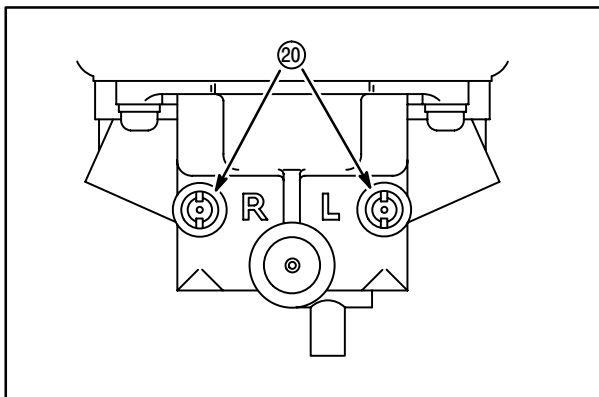


Fig. 73

13. Install lower body gasket (21), **Fig. 74**. Make sure gasket does not twist or kink.

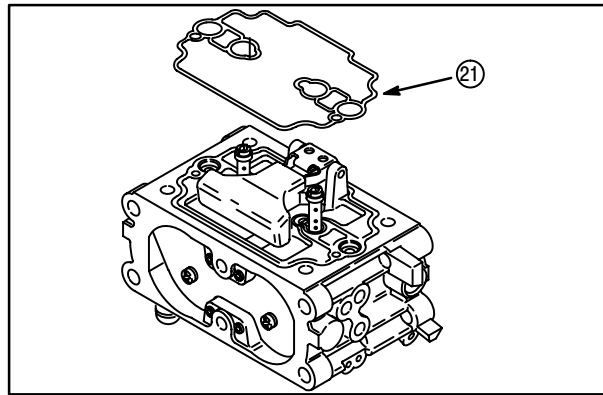


Fig. 74

14. Assemble lower body with main jet plugs (23) facing throttle shaft side (24) of carburetor. Make sure gasket remains in position, **Fig. 75**. Tighten screws (22) securely.

15. Install anti-afterfire solenoid with washer. Torque to **90 in. lbs. (10 Nm)**.

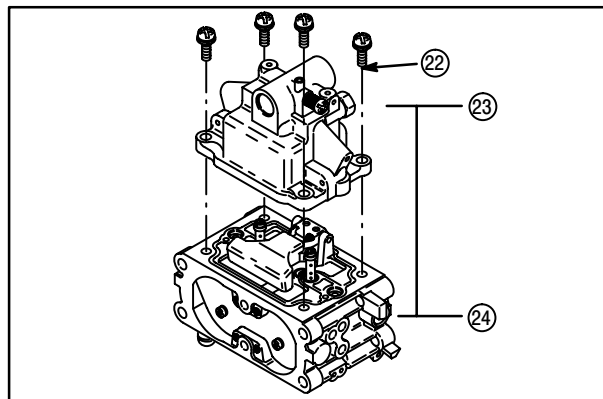


Fig. 75

#### Nikki Carburetor

**Models 290400, 303400, 350400 (After 950731xx)**

#### **Check Throttle, Choke Shaft and Body For Wear**

**NOTE:** The measurement in Step 1 is taken with the carburetor off of the intake manifold.

1. Lay carburetor on 1/4" (6.35 mm) raised flat surface (1). Use a feeler gauge (2) to check throttle and choke shaft clearance as shown in **Fig. 76**.

Throttle shaft and choke shaft clearance must not exceed **0.010" (0.25 mm)**.

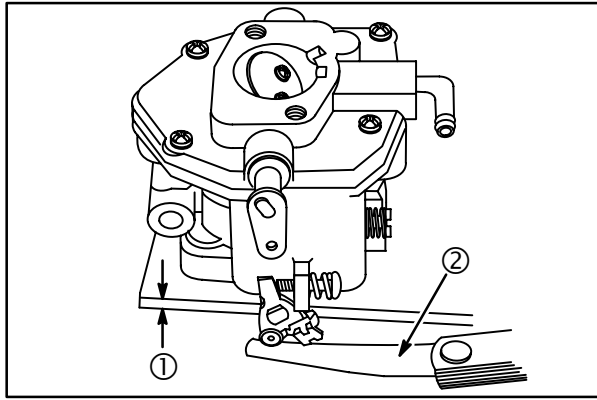


Fig. 76

**NOTE:** The inspection in Step 2 is performed after the carburetor has been disassembled.

2. Inspect throttle shaft and choke shaft for wear (3), **Fig. 77**. Replace if worn.

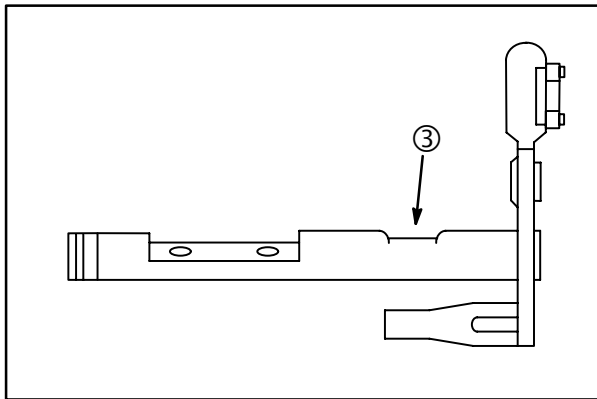


Fig. 77

Replace either shaft if worn.

Replace the carburetor if the body is worn or if either shaft clearance exceeds **0.010" (0.25 mm)** when a new shaft is used.

**Disassemble**

1. Remove four screws and upper body (1), **Fig. 78**. Do not damage emulsion tube (2) in upper body.

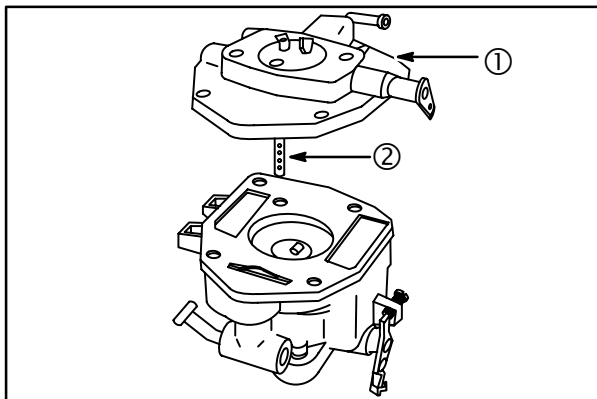


Fig. 78

2. Remove and discard gasket.

3. Remove float and inlet needle.

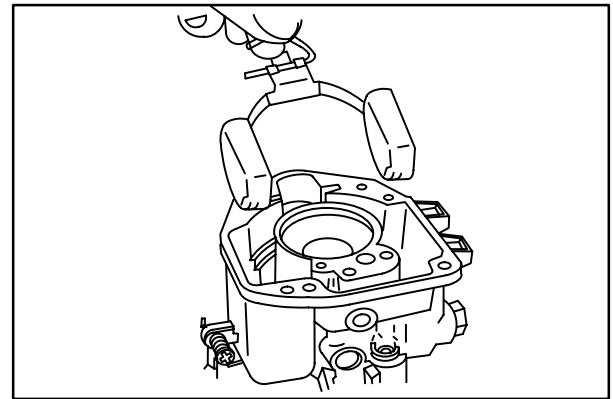


Fig. 79

If idle mixture screw is equipped with adjustment limiter cap (9), use a pliers to remove it before removing idle mixture screw (inset), **Fig. 80**.

4. Remove idle mixture screw (3) and spring (4), **Fig. 80**.
5. Remove anti-afterfire solenoid (8), if equipped, or plug (7) and washer (6).
6. Remove fixed main jet (5) using Screwdriver, #19062.

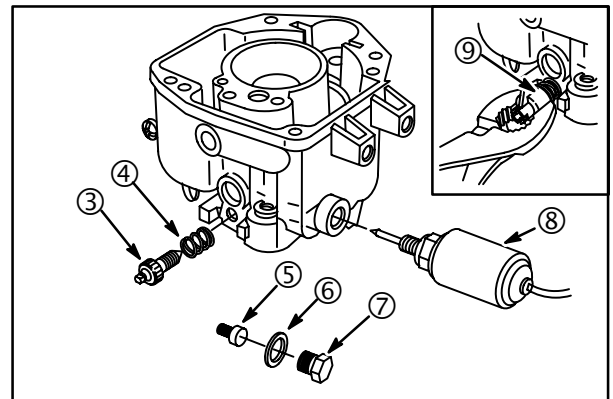


Fig. 80

7. Remove pilot jet (10) using Screwdriver #19061, **Fig. 81**.

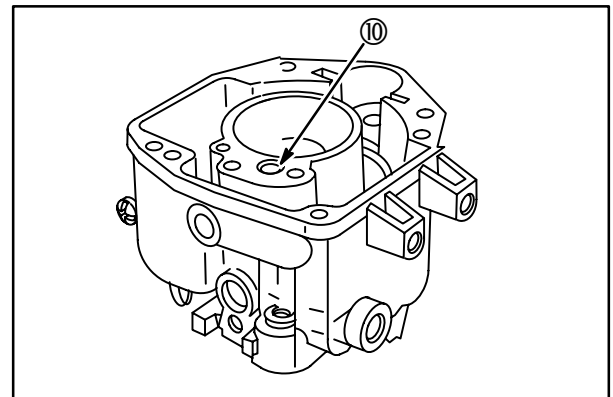


Fig. 81



8. The top and bottom edges of the throttle plate are beveled. Mark throttle plate (11), **Fig. 82** before removal to ensure reinstallation in the original position.
9. Remove throttle shaft (13) and spacer (14).
10. Remove throttle shaft seal (12).

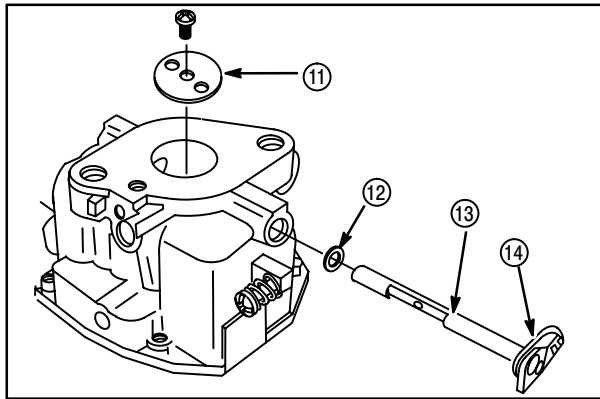


Fig. 82

Support upper body on a vise or wood block so that emulsion tube (19) will not be damaged, **Fig. 83**.

11. Mark choke plate (15) before removal to ensure reinstallation in the original position.
12. Remove choke shaft (18) and spacer (17).
13. Remove seal (16).

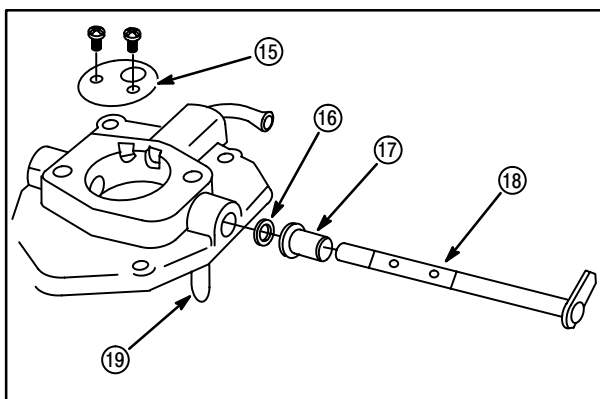


Fig. 83

14. Remove transitional hole welch plug (20) with a punch as shown, **Fig. 84**.

This completes the carburetor disassembly procedure.

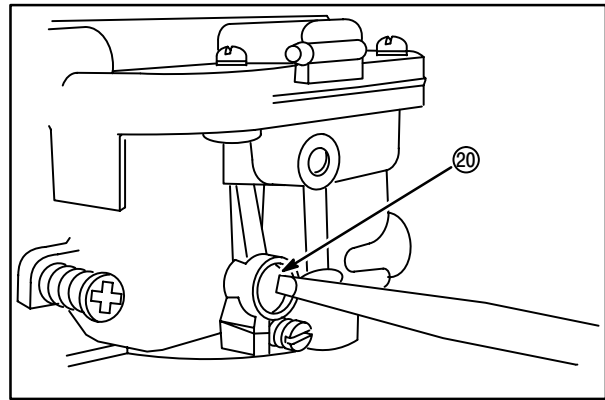



Fig. 84

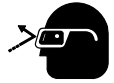
### Clean Carburetor

1. Disassemble carburetor.
2. Remove and discard all old gaskets, seals and sealing material.

	 <b>CAUTION</b>
	<b>AVOID INJURY!</b>
<ul style="list-style-type: none"> <li>• Wear suitable protection when using cleaners. Follow instructions on container.</li> </ul>	

3. Use a commercial carburetor cleaner (such as Briggs & Stratton Spray Cleaner, #100041 or #100042) to clean carburetor parts and body.

**NOTE:** Do not use commercial carburetor cleaners on parts containing rubber, such as seals, O-rings, inlet needles, seats or pump diaphragms. Do not leave non-metallic parts (plastic, nylon, Minlon™, etc.) in commercial carburetor cleaner more than 15 minutes.

	 <b>CAUTION</b>
	<b>AVOID EYE INJURY!</b>
<ul style="list-style-type: none"> <li>• Wear eye protection whenever using compressed air to clean parts.</li> </ul>	

4. Use only compressed air (blowing in both directions) to clean out all openings and passages.

**NOTE:** Do not use wire, drills or other mechanical devices to clean out metering holes or passages.

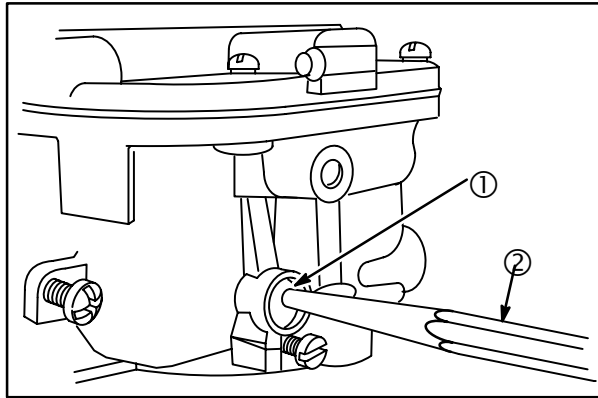
### Inspect Carburetor

Inspect all parts for wear, cracks, nicks and burrs. Inspect float for leaks. Replace damaged parts.

### Assemble Carburetor

When assembling carburetor, use new seals and gaskets.

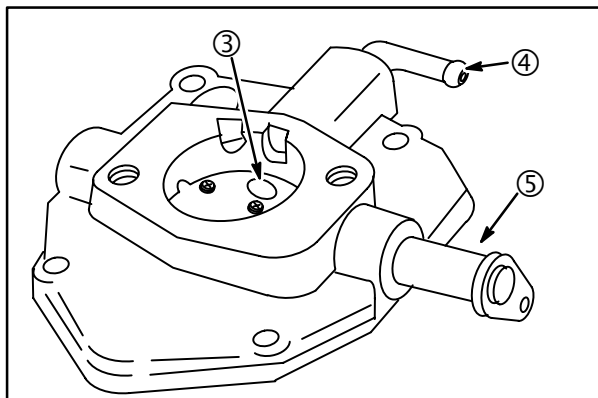
1. Install new transitional hole welch plug (1), **Fig. 85**.
2. Use a round punch (2). Tap in plug until it is flat.
3. Use a sealant such as Permatex® #2 or nail polish on outside diameter of plug to prevent air leaks.



**Fig. 85**

4. Install new choke shaft seal with sealing lip in.
5. Install choke shaft and spacer (5), **Fig. 86**.
6. Install choke plate (3) with vent hole facing bowl vent nipple (4).

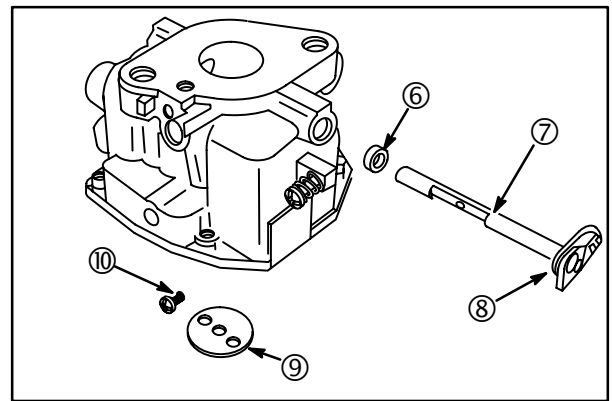
**NOTE:** Use LOCTITE® 222 on screw threads.



**Fig. 86**

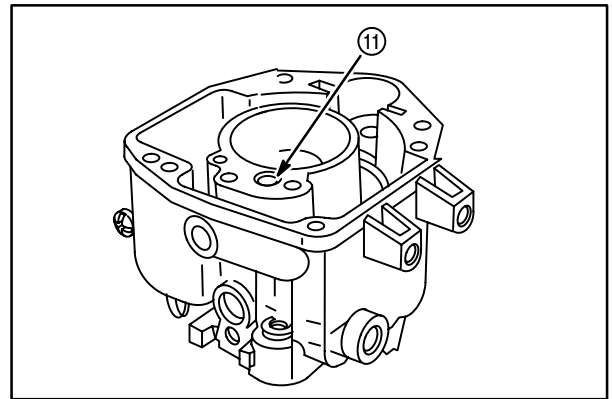
7. Install new throttle shaft seal (6) with sealing lip in, **Fig. 87**.
8. Install throttle shaft (7) and spacer (8).
9. Install throttle plate (9) to throttle shaft.

**NOTE:** Use LOCTITE® 222 on screw threads (10).



**Fig. 87**

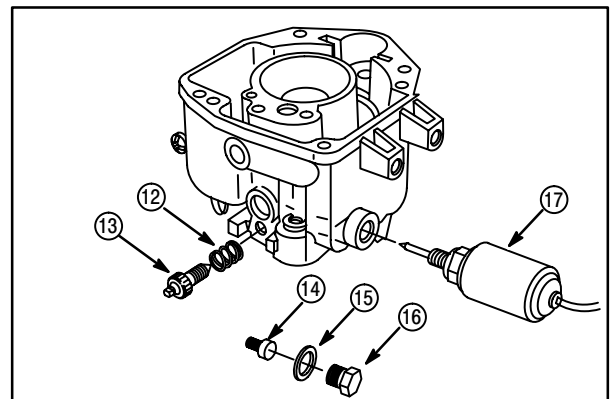
10. Install pilot jet (11) using Screwdriver #19061, **Fig. 88**.



**Fig. 88**

11. Install fixed main jet (14) using Screwdriver #19062, **Fig. 89**.
12. Install washer (15) and plug (16) or anti-afterfire solenoid (17). Torque to **45 in. lbs. (5 Nm)**.
13. Install idle mixture screw (13) and spring (12).

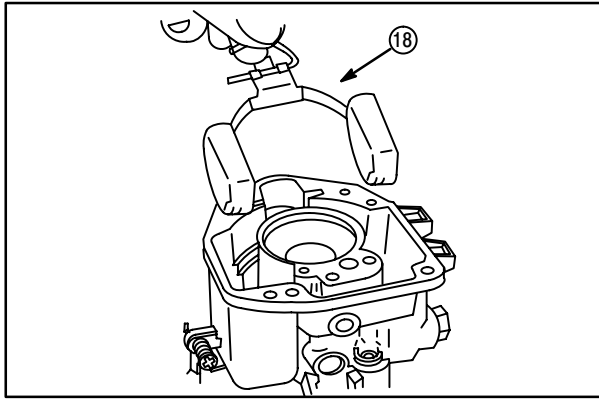
**NOTE:** DO NOT tighten screw. DO NOT install limiter cap at this time.



**Fig. 89**

14. Assemble inlet needle to float. Install float assembly (18), **Fig. 90**.

**NOTE:** Use brass inlet needle for fuel pump carburetors. Use aluminum inlet needle for gravity feed carburetors.

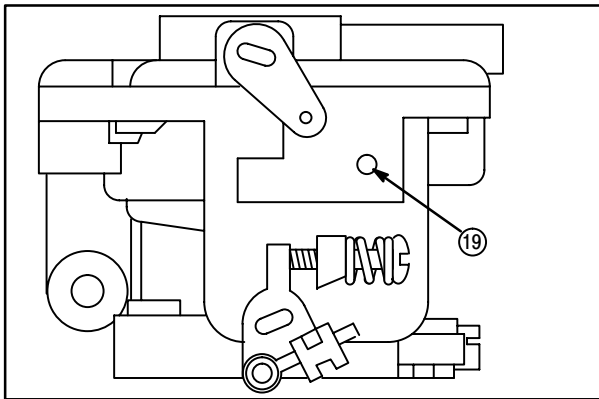


**Fig. 90**

The fuel inlet seat orifice size and inlet needle are different, depending upon the type of fuel delivery system used. The carburetor bodies and inlet needles are not interchangeable.

A color code on the side of the carburetor (19) is used to identify the carburetor by engine model and fuel delivery system, **Fig. 91**.

**NOTE:** See the “Fuel System Identification Table” in the Appendix for information.



**Fig. 91**

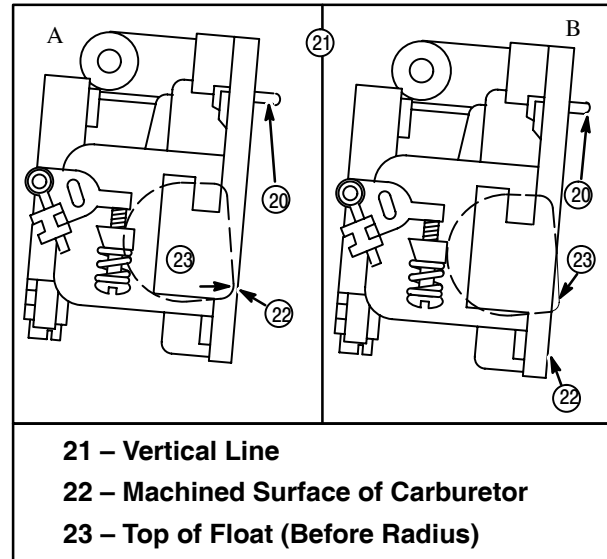
### Set Float Height

The float height setting on Nikki carburetors depends upon whether the engine uses a fuel pump (illustration **A**) or gravity feed fuel delivery system (illustration **B**), **Fig. 92**. The procedure for checking the float height setting is unique to each carburetor.

1. Hold the carburetor in one hand and place the index finger on the float hinge pin (20).
2. While holding the float hinge pin down, turn the carburetor to a position PAST VERTICAL (21)

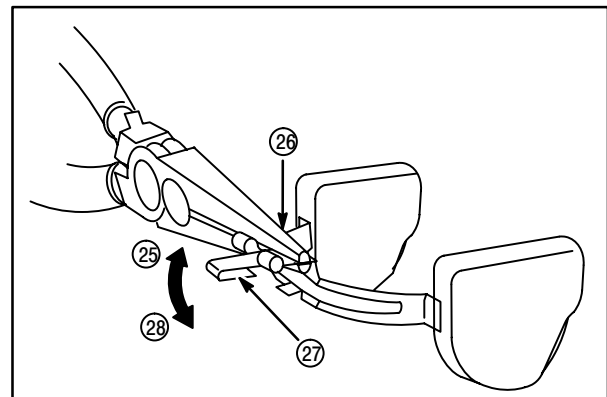
as shown in **Fig. 92**. This allows the weight of the float to close the inlet needle.

3. The float height is the dimension between the top flat area of the float just before the radius (23) and the machined surface of the carburetor (22).
  - a. Float height for fuel pump carburetors (A) is **1/16” (1.6 mm) BELOW** machined surface (22).
  - b. Float height for gravity feed carburetors (B) is **3/32” (2.4 mm) ABOVE** machined surface (22).



**Fig. 92**

To adjust float level, hold float arm at (26) with needle nose pliers, **Fig. 93**. Carefully bend tang **CLOCKWISE** (25) to raise the float level, **COUNTER-CLOCKWISE** (28) to lower the float level. **DO NOT** collapse hooked end of float tang (27).



**Fig. 93**

4. Place new gasket (31) on lower carburetor body (32). Make sure holes in body line up with holes in gasket, **Fig. 94**.
5. Install upper carburetor body (30). Tighten screws (29) securely.

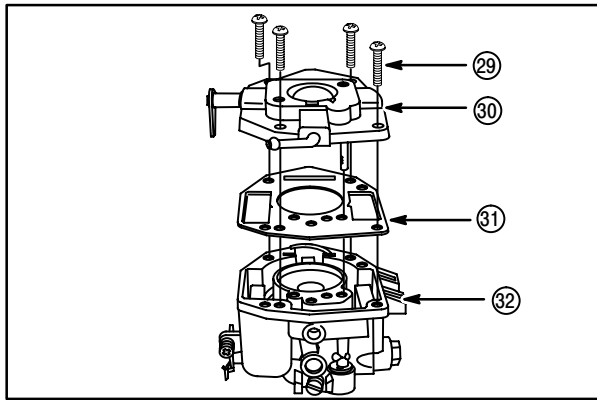


Fig. 94

**Mikuni Carburetor**

**Models 290400, 303400, 350400 (Before 950801xx)**

**Carburetor Identification**

Two carburetor bodies are used, depending upon the use of a fuel pump (illustration A) or gravity feed (illustration B) fuel delivery system, **Fig. 95**.

Besides a change in jetting, the end of the discharge nozzle is machined at a different angle. Since the discharge nozzle is an integral part of the carburetor body the carburetor bodies are not interchangeable.

The carburetor bodies can be identified by looking down the carburetor throat and comparing the end of the discharge nozzle (1) in relation to the choke shaft (2), **Fig. 95**. On a fuel pump carburetor the end of the nozzle is at approximately a 20° angle (3) to the choke shaft (2). On a gravity feed carburetor the end of the nozzle is approximately parallel (4) to the choke shaft. The fixed main jet used with a fuel pump system is numbered 110. The fixed main jet used with a gravity system is numbered 117.5.

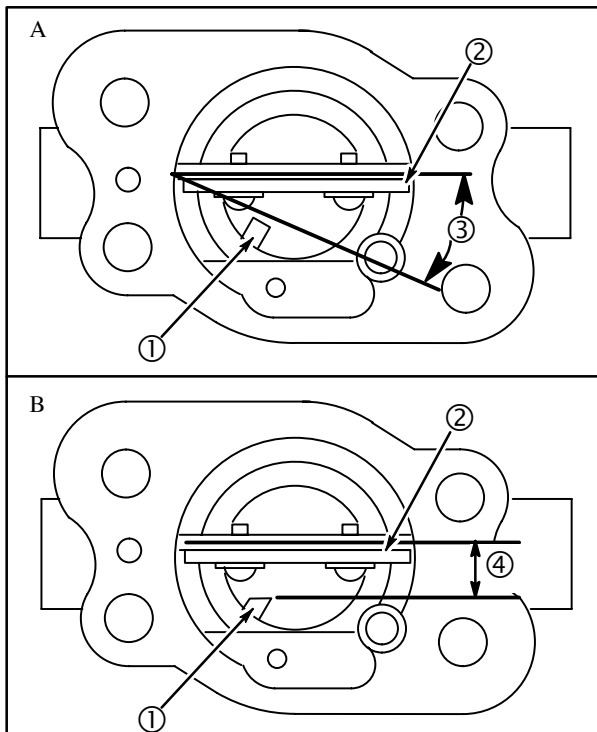


Fig. 95

**Check Throttle, Choke Shaft and Body For Wear**

**NOTE:** The measurement in Step 1 is taken with the carburetor off of the intake manifold.

1. Lay carburetor on 1/8" (3 mm) raised flat surface (1). Use a feeler gauge (2) to check throttle and choke shaft clearance as shown in **Fig. 96**.

Throttle shaft and choke shaft clearance must not exceed 0.010" (0.25 mm).

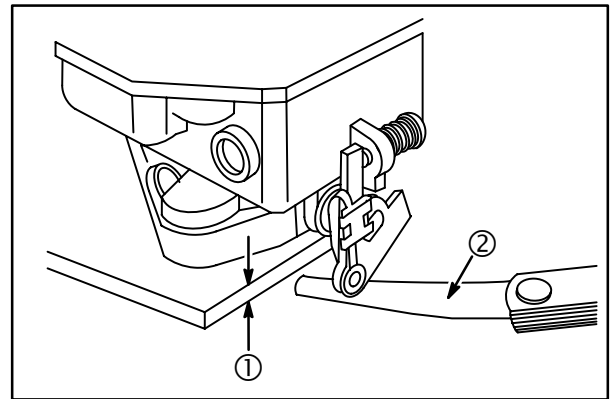


Fig. 96

**NOTE:** The inspection in Step 2 is performed after the carburetor has been disassembled.

2. Inspect throttle shaft and choke shaft for wear (3), **Fig. 97**. Replace if worn.

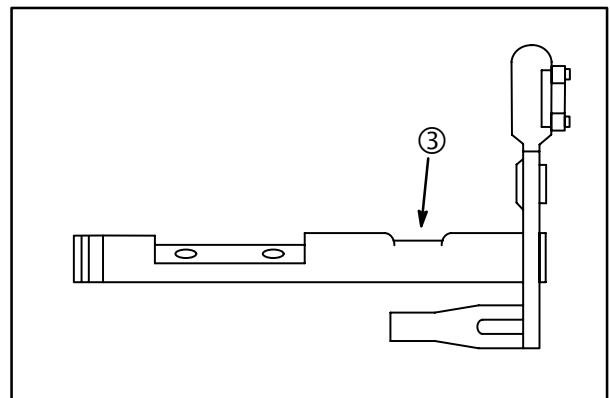


Fig. 97

Replace either shaft if worn.

Replace the carburetor if the body is worn or if the clearance on either shaft exceeds 0.010" (0.25 mm) when a new shaft is used.

**Disassemble**

1. Remove pilot jet (1), **Fig. 98**.
2. Remove four screws (2) and upper body (3). Discard gasket (4).

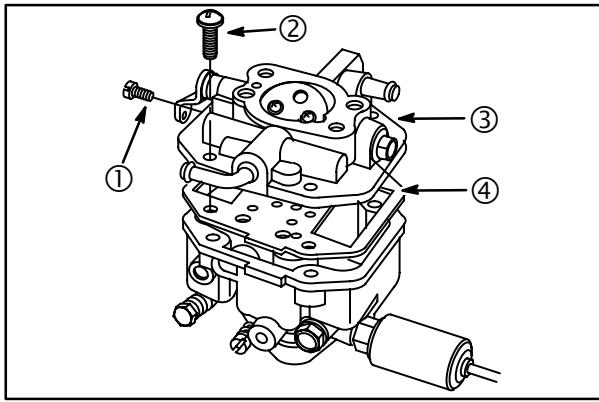


Fig. 98

3. Remove float (5) and fuel inlet needle (6), Fig. 99.

**NOTE:** Float hinge pin (7) is swaged on one end. Drive hinge pin out from side opposite swage.

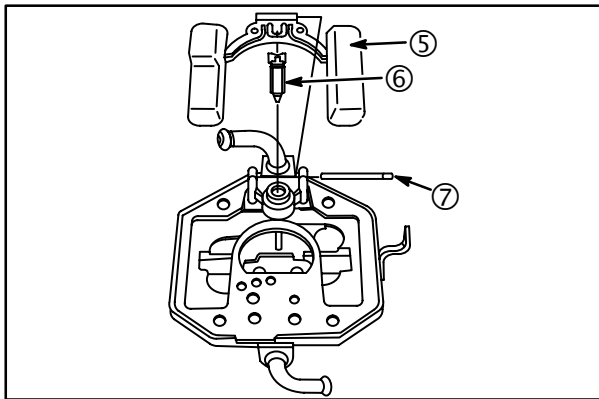


Fig. 99

4. Remove anti-afterfire solenoid (10) or plug (9), Fig. 100.
5. Remove fixed jet plug (13) and washer (12).
6. Remove fixed main jet (11) with Jet Screwdriver #19062.
7. Remove emulsion tube (8).

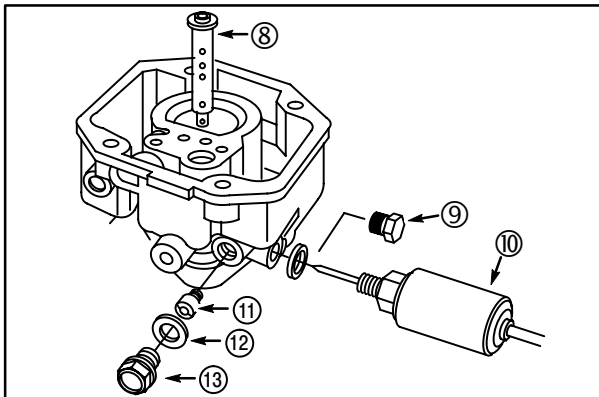


Fig. 100

If equipped, remove adjustment limiter cap (14) with a pliers (inset) before removing idle mixture screw, Fig. 101.

8. Remove idle mixture screw (16) and spring.
9. Remove fuel bowl drain screw (15) and spring.

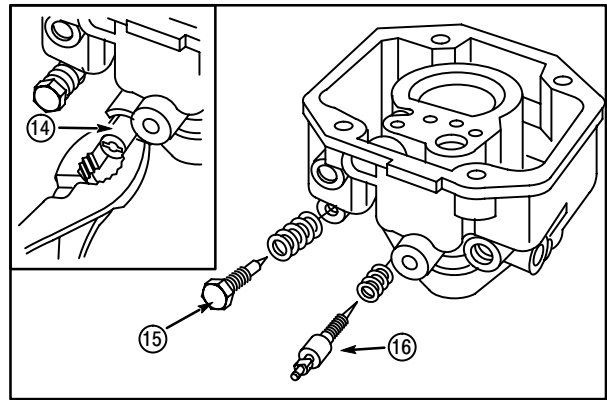


Fig. 101

10. Mark throttle plate (21), Fig. 102, before removing to ensure re-installation in the original position. Top and bottom edges are beveled. Remove screws (20) and throttle plate.
11. Remove retainer (22).
12. Remove throttle shaft with foam seals (18) and spacer (17).
13. Remove seals (19).

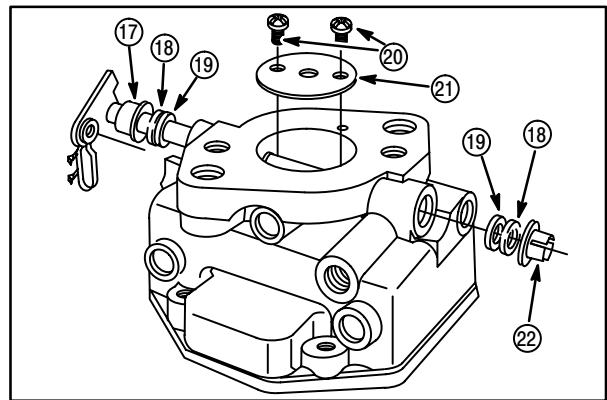
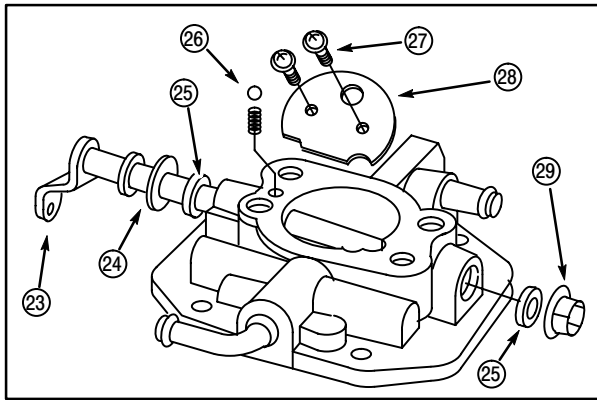


Fig. 102

14. Mark choke plate before removal to ensure re-installation in the original position. Top and bottom edges are beveled. Remove screws (27) and choke plate (28), Fig. 103.
15. Remove retainer (29).
16. Remove choke shaft (23) and spacer (24).
17. Remove seals (25).

**NOTE:** Carburetor body has a ball and spring (26) that keeps tension on choke shaft. Use care when removing choke shaft.

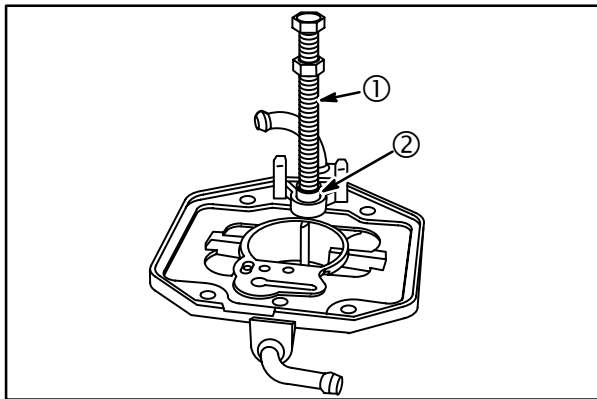


**Fig. 103**

### Remove Fuel Inlet Body and Seat

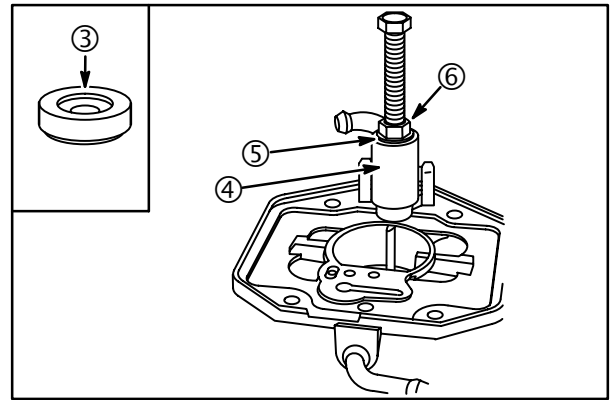
The fuel inlet body must be removed before the inlet seat can be removed.

1. Use self-threading screw #93029 (1) from Fly-wheel Puller #19165. Thread screw into seat body (2) 3 - 4 turns, Fig. 104.
2. Back the screw out of the seat body.



**Fig. 104**

3. Install 1/4" x 20 Nut #92278 (6) and Washer #224061 (5) from Tool Kit #19332 onto screw, Fig. 105.
4. Place a 1/4" drive 3/8" (9 mm) socket (4) over seat body.
5. Install screw, washer and nut to seat body. Thread nut down on washer.
6. Continue turning until seat body is removed.
7. Remove fuel inlet seat (3).



**Fig. 105**

This completes the carburetor disassembly procedure.

### Clean Carburetor

1. Disassemble carburetor.
2. Remove and discard all old gaskets, seals and sealing material.

	<b>CAUTION</b>
	<b>AVOID INJURY!</b>
<ul style="list-style-type: none"> <li>• Wear suitable protection when using cleaners. Follow instructions on container.</li> </ul>	

3. Use a commercial carburetor cleaner (such as Briggs & Stratton Spray Cleaner, #100041 or #100042) to clean carburetor parts and body.

**NOTE:** Do not leave non-metallic parts (plastic, nylon, Minlon™, etc.), in commercial carburetor cleaner more than 15 minutes. Do not use commercial carburetor cleaners on parts containing rubber, such as seals, O-rings, inlet needles, seats or pump diaphragms.

	<b>CAUTION</b>
	<b>AVOID EYE INJURY!</b>
<ul style="list-style-type: none"> <li>• Wear eye protection whenever using compressed air to clean parts.</li> </ul>	

4. Use only compressed air (blowing in both directions) to clean out all openings and passages.

**NOTE:** Do not use wire, drills or other mechanical devices to clean out metering holes or passages.

## Inspect Carburetor

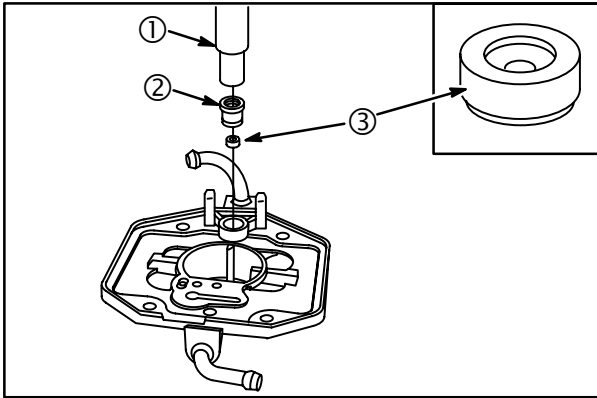
Inspect all parts for wear, cracks, nicks and burrs. Inspect float for leaks. Replace damaged parts.

## Assemble Carburetor

When assembling carburetor, use new seals and gaskets.

### Install Fuel Inlet Seat and Body

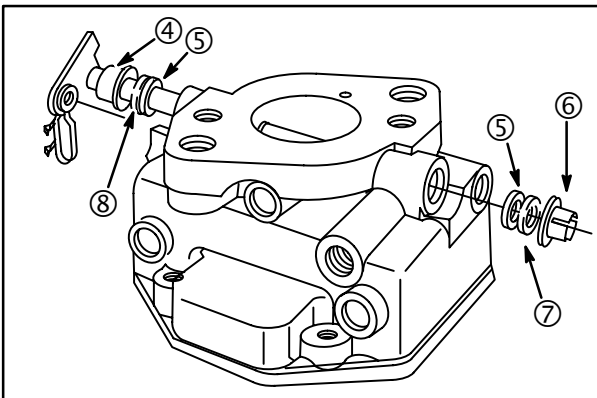
1. Install new inlet seat (3) with chamfered end down, **Fig. 106**.
2. Press in new body (2) using Tool #19135 (1).



**Fig. 106**

3. Install new throttle shaft seals (5) with sealing lip out, **Fig. 107**.
4. Install throttle shaft with spacer (4) and foam seal (8).
5. Install foam seal (7) and retainer (6).
6. Install throttle plate.

**NOTE:** Use LOCTITE® 222 on screw threads.

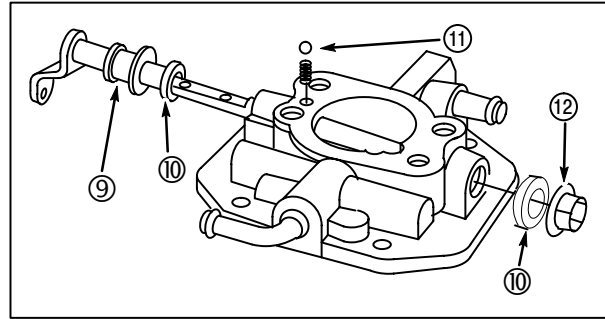


**Fig. 107**

7. Install new choke shaft seals (10) with sealing lip out, **Fig. 108**.

8. Assemble spacer (9) onto choke shaft.
9. Insert spring and check ball (11) in to spring pocket. Compress with a small round punch.
10. Push choke shaft into hole until ball engages groove in choke shaft.
11. Install retainer (12) to shaft.
12. Install choke plate.

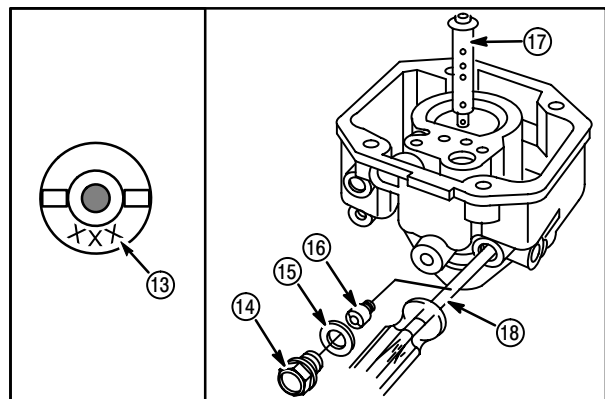
**NOTE:** Use LOCTITE® 222 on screw threads.



**Fig. 108**

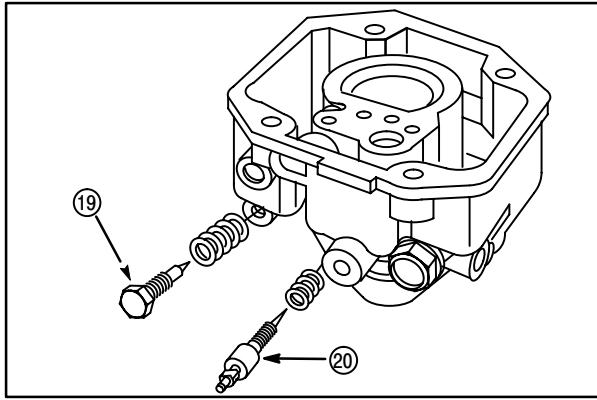
13. Install fixed main jet (16) with Jet Screwdriver #19062 (18), **Fig. 109**.
14. Install washer (15) and plug (14).
15. Install emulsion tube (17).

**NOTE:** Fixed main jets are numbered (13) for the type of fuel delivery system used. Install #110 jet if engine is equipped with a fuel pump. Install #117.5 jet if engine is equipped with a gravity fuel tank.



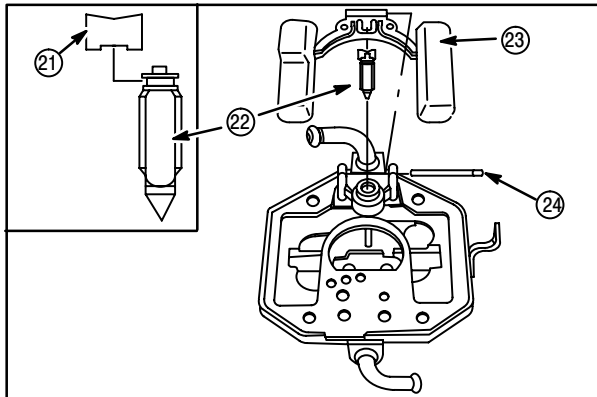
**Fig. 109**

16. Install bowl drain screw (19) and spring, **Fig. 110**.
17. Install idle mixture screw (20) and spring.  
DO NOT tighten screw.  
DO NOT install limiter cap at this time.



**Fig. 110**

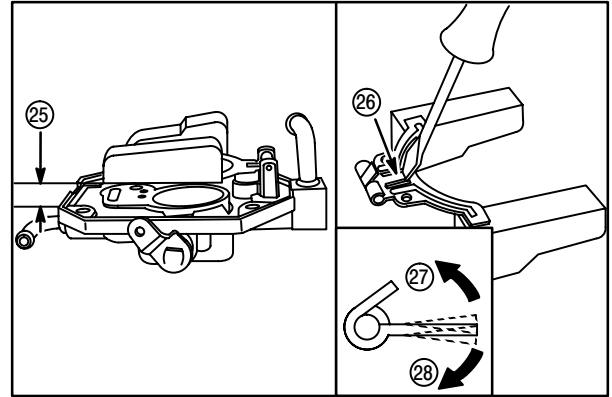
18. Assemble inlet needle retainer (21) to inlet needle (22). Assemble to float (23), **Fig. 111**.
19. Install float (23) and needle to upper carburetor body. Insert hinge pin (24).



**Fig. 111**

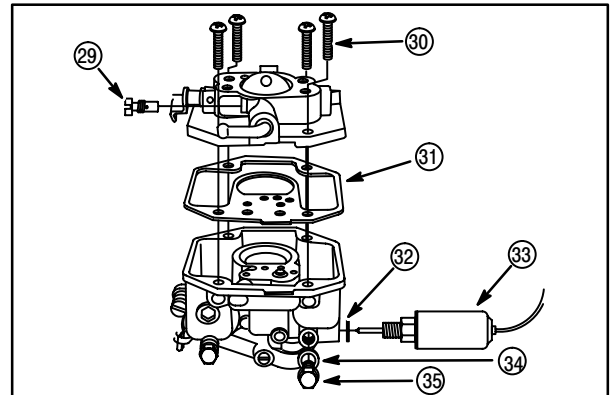
20. Invert upper carburetor body as shown in **Fig. 112**.
  - The float should be parallel (25) with carburetor bowl mounting surface.
  - If not, use a small screw driver to bend tang (26) and lower (27) or raise (28) the float level as shown.

**CAUTION: DO NOT** press on float to adjust.



**Fig. 112**

21. Place new gasket (31) on lower carburetor body. Make sure holes in body line up with holes in gasket, **Fig. 113**.
22. Install upper carburetor body. Tighten screws (30) securely.
23. Install pilot jet (29).
24. Install washer (34) and plug (35) or anti-afterfire solenoid (33). Torque to **45 in. lbs. (5 Nm)**.



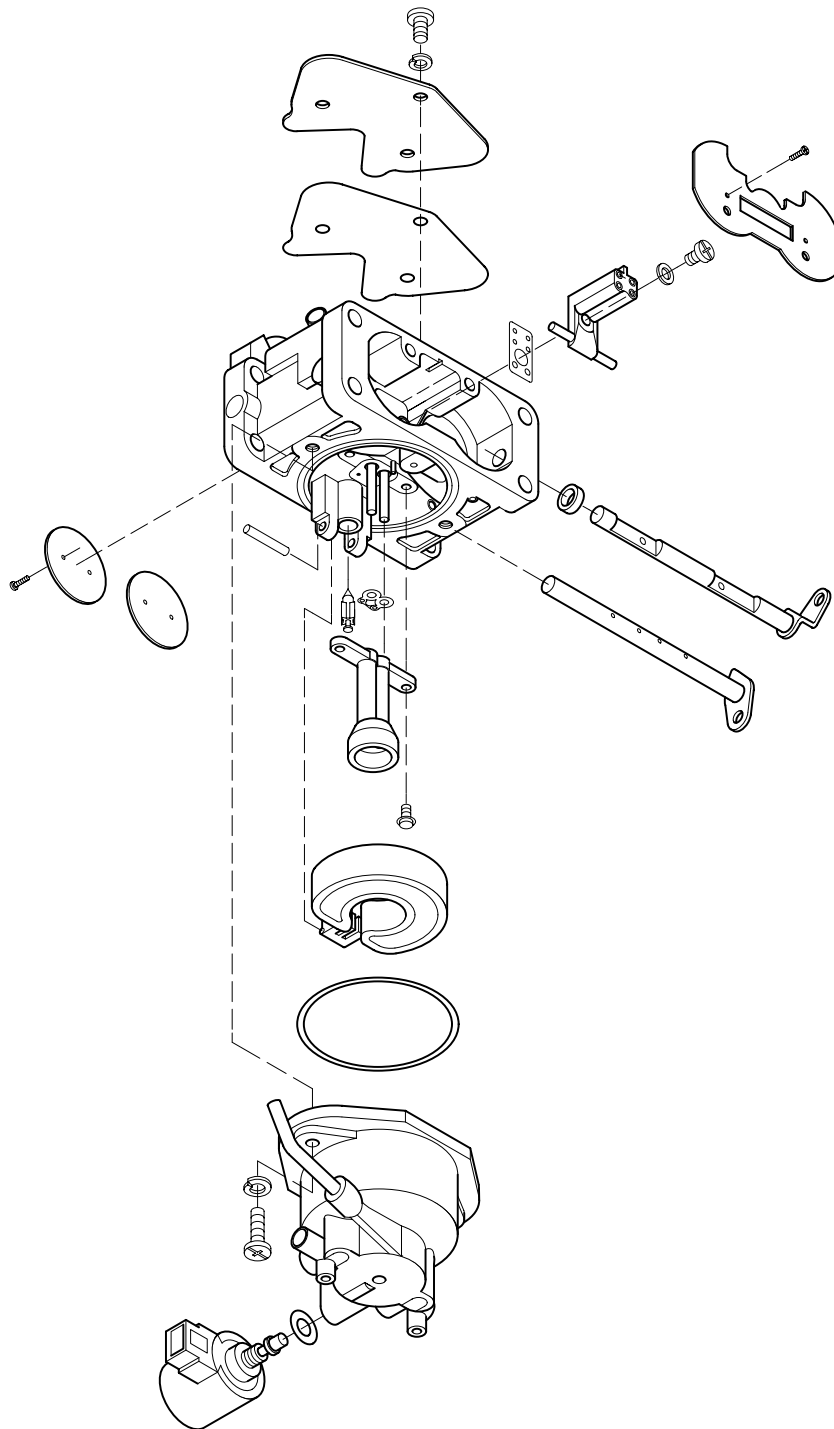
**Fig. 113**



## Nikki Carburetor

### Model 540000

4

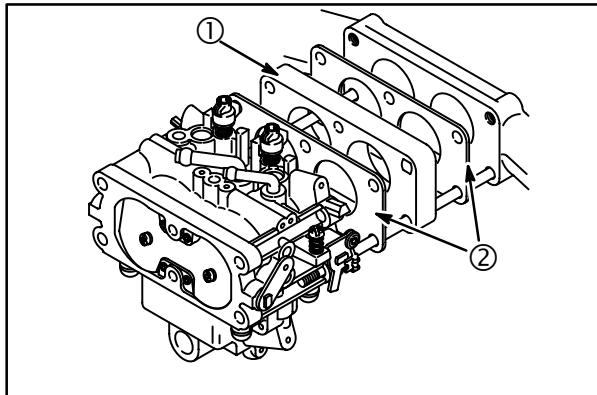


### General Information

The Vanguard™ Model 540000 OHV V-Twin utilizes a fixed jet, two barrel, side draft, flo-jet carburetor. Except for idle speed, the carburetor is non-adjustable. The carburetor incorporates a fuel shut-off (anti-afterfire) solenoid that controls fuel flow to the fuel metering system. The solenoid is controlled by the ignition switch.

## Remove Carburetor from Manifold

Remove carburetor gaskets (2) and spacer (1), **Fig. 114**. Discard carburetor gaskets.



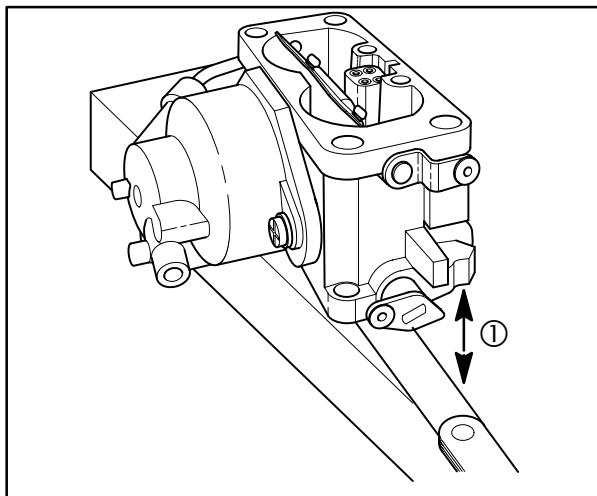
**Fig. 114**

## Check Throttle, Choke Shaft and Body

**NOTE:** The measurement in Step 1 is taken with the carburetor off of the intake manifold.

1. Lay carburetor on flat surface and check throttle and choke shaft clearance as shown in **Fig. 115**.

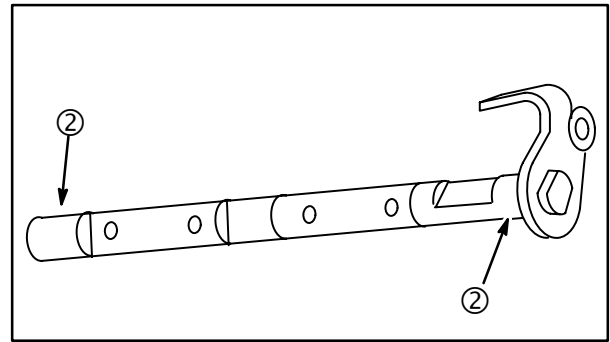
Throttle shaft and choke shaft clearance (1) must not exceed **0.010" (0.25 mm)**.



**Fig. 115**

**NOTE:** The inspection in Step 2 is performed after the carburetor has been disassembled.

2. Inspect throttle shaft and choke shaft for wear on the shaft bore surfaces (2), **Fig. 116**.



**Fig. 116**

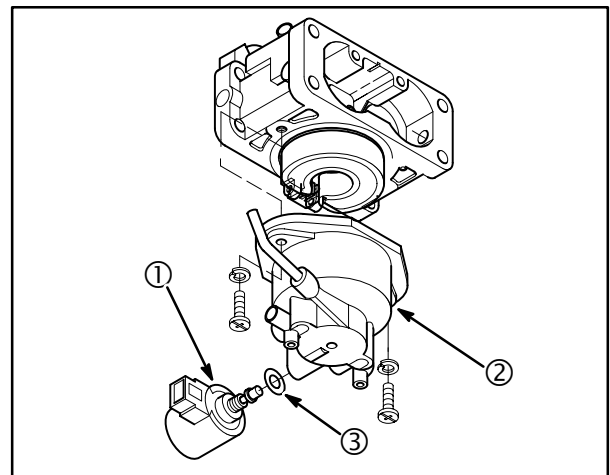
Replace either shaft if worn.

Replace the carburetor if the body is worn or if either shaft clearance exceeds **0.010" (0.25 mm)** when a new shaft is used.

## Disassemble

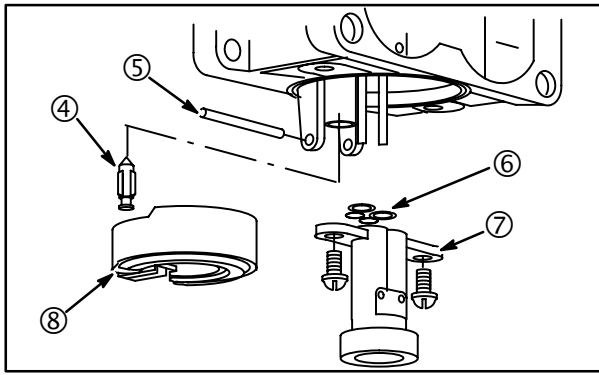
1. Remove carburetor, see Section 3.
2. Remove two screws and float bowl (2), **Fig. 117**. Discard O-ring.
3. Use **13 mm** thin profile wrench to remove fuel solenoid (1) from float bowl. Discard gasket (3).

**CAUTION:** Do not damage fixed main jet and housing when removing solenoid.

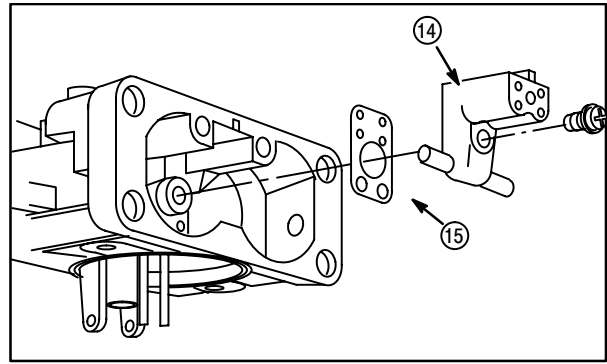


**Fig. 117**

4. Remove main jet from carburetor body.
5. Remove float hinge pin (5), float (8) and inlet needle (4), **Fig. 118**.
6. Remove emulsion tube body (7) and gasket (6). Discard gasket.



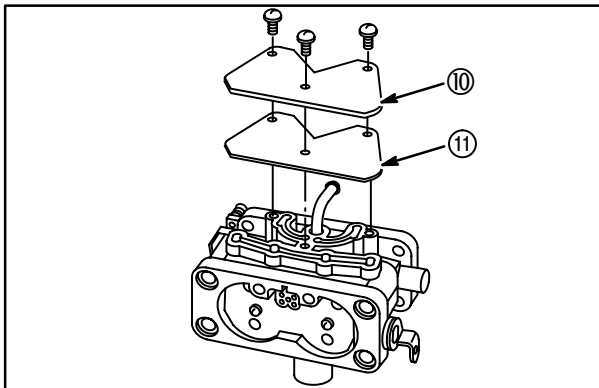
**Fig. 118**



**Fig. 121**

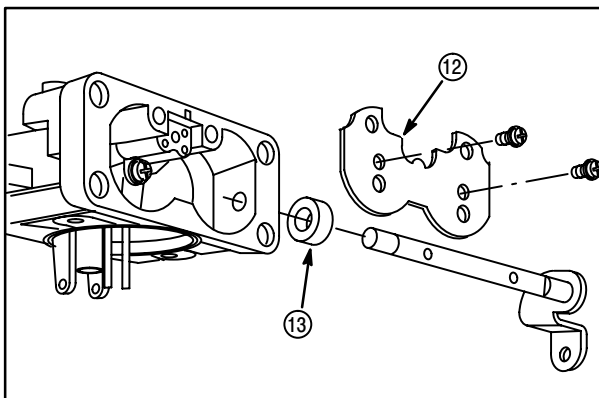
**4**

7. Remove cover plate (10). Discard gasket (11), **Fig. 119**.



**Fig. 119**

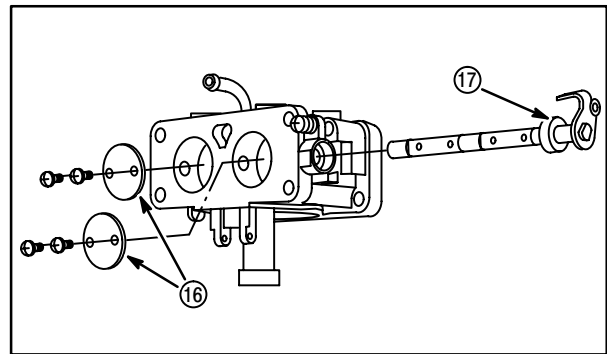
8. Remove screws and choke plate (12), **Fig. 120**.  
 9. Remove choke shaft. Discard seal (13).



**Fig. 120**

10. Remove nozzle body (14), **Fig. 121**. Discard gasket (15).

11. Mark throttle plates (16), **Fig. 122**, before removal so they will be re-installed in the original position. Sides of throttle plate are beveled.



**Fig. 122**

12. Remove screws, throttle plates and throttle shaft with seal. Discard seal (17).

This completes the carburetor disassembly procedure.


**Clean Carburetor**

1. Disassemble carburetor.
2. Remove and discard all old gaskets, seals and sealing material.

	<b>CAUTION</b>
	<b>AVOID INJURY!</b>
<ul style="list-style-type: none"> <li>• Wear suitable protection when using cleaners. Follow instructions on container.</li> </ul>	

3. Use a commercial carburetor cleaner (such as Briggs & Stratton Spray Cleaner, #100041 or 100042) to clean carburetor parts and body.

**NOTE:** Parts containing rubber, such as seals, O-rings, inlet needles, seats or pump diaphragms should not be placed in commercial carburetor cleaner. Do not leave non-metallic parts (plastic, nylon, Minlon™, etc.), in commercial carburetor cleaner more than 15 minutes.

	<p style="text-align: center;"><b>CAUTION</b></p>
<p><b>AVOID EYE INJURY!</b></p>	
<ul style="list-style-type: none"> <li>• Wear eye protection whenever using compressed air to clean parts.</li> </ul>	

4. Use only compressed air (blowing in both directions) to clean out all openings and passages.

**NOTE:** Do not use wire, drills or other mechanical devices to clean out metering holes or passages.

### Inspect Carburetor

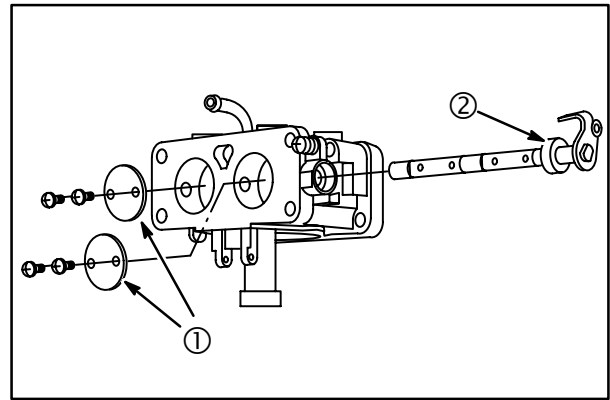
Inspect all parts for wear, cracks, nicks and burrs. Inspect float for leaks. Replace damaged parts.

### Assemble Carburetor

When assembling carburetor, use new seals and gaskets.

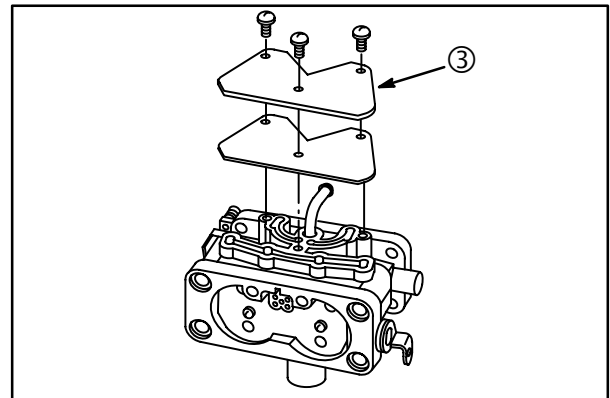
1. Assemble new seal (2) to throttle shaft and insert into carburetor body, **Fig. 123**.

**NOTE:** Install one throttle plate (1) at a time. Check throttle for freedom of operation before installing other throttle plate. Use LOCTITE® 222 on screw threads.



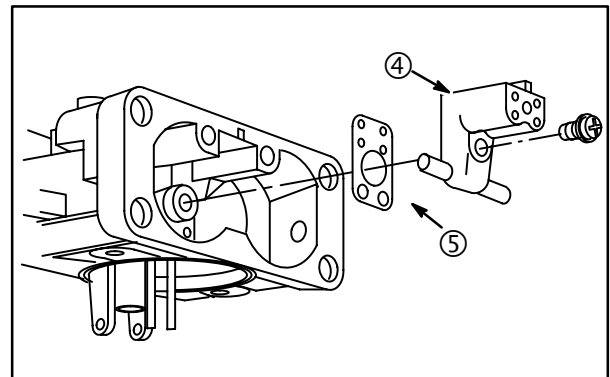
**Fig. 123**

2. Install cover plate (3) with new gasket, **Fig. 124**.



**Fig. 124**

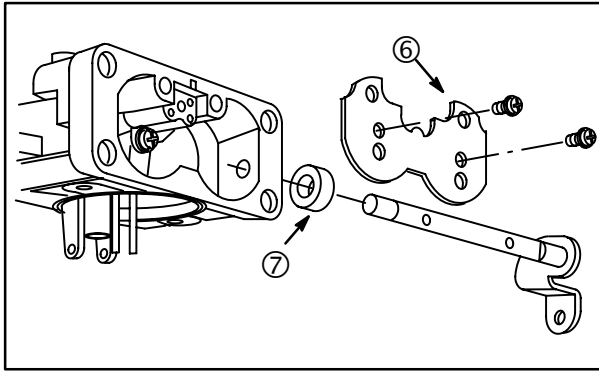
3. Install nozzle body (4) with new gasket (5), **Fig. 125**. Tighten screw securely.



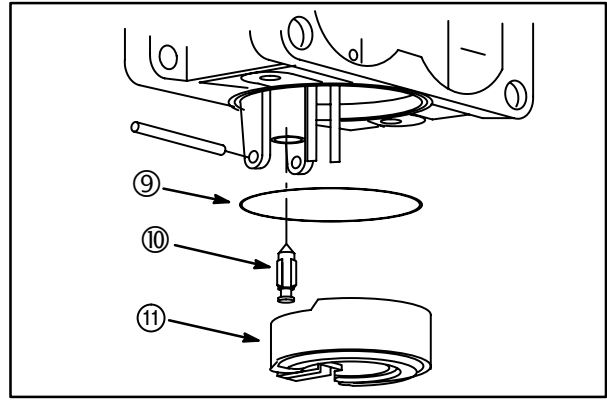
**Fig. 125**

4. Assemble new seal (7) to choke shaft and insert into carburetor body, **Fig. 126**.
5. Install choke plate (6).

**NOTE:** Use LOCTITE® 222 on screw threads.



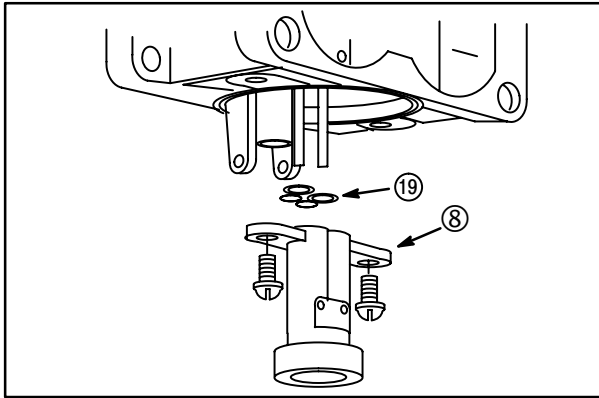
**Fig. 126**



**Fig. 128**

**4**

6. Install emulsion tube body (8) with new gasket (19), **Fig. 127**. Tighten screw securely.

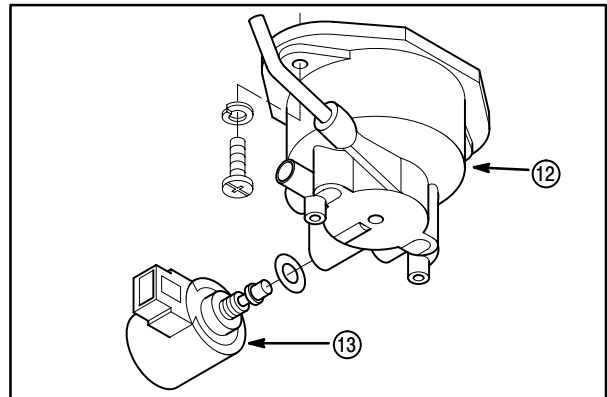


**Fig. 127**

7. Assemble inlet needle (10) to float (11) and install float, **Fig. 128**.

8. Assemble bowl gasket (9) to body.
9. Install main jet, according to engine model.
10. Install the float bowl assembly to the carburetor body.
11. Assemble fuel solenoid (13) to float bowl (12), **Fig. 129**. Use a **13 mm** thin profile wrench to tighten the solenoid.

**CAUTION:** Use care when tightening solenoid to prevent damage to fixed main jet and housing.

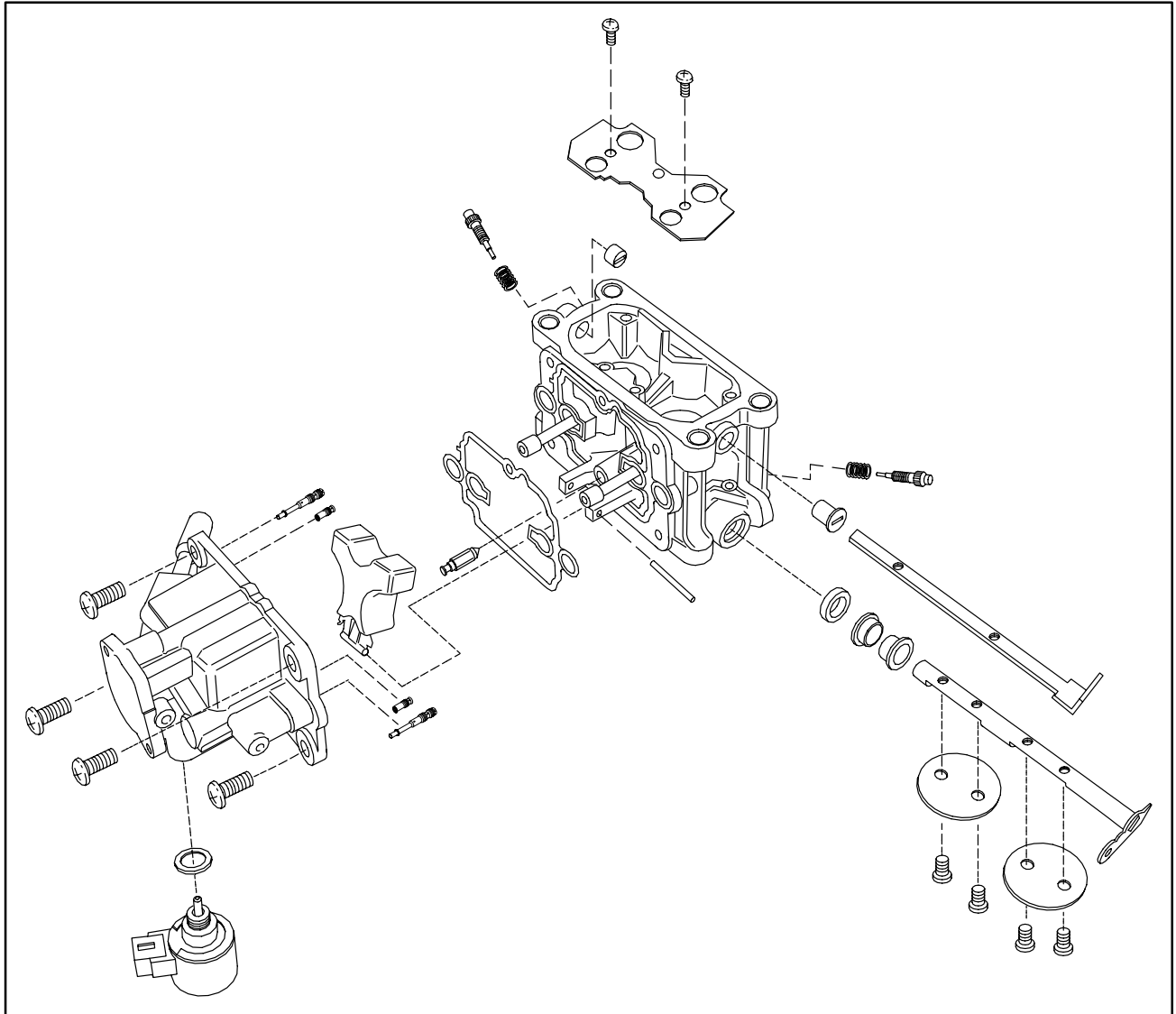


**Fig. 129**

12. Assemble float bowl to carburetor body.

## Aisan Carburetor

### Model 610000



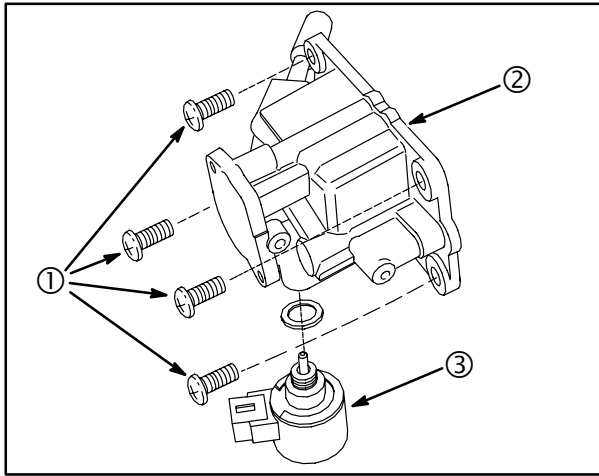
4

### General Information

The Vanguard™ Model 610000 OHV V-Twin utilizes a fixed jet, two barrel, side draft, flo-jet carburetor. The carburetor incorporates a fuel shut-off (anti-afterfire) solenoid that controls fuel flow to the fuel metering system. The solenoid is controlled by the ignition switch.

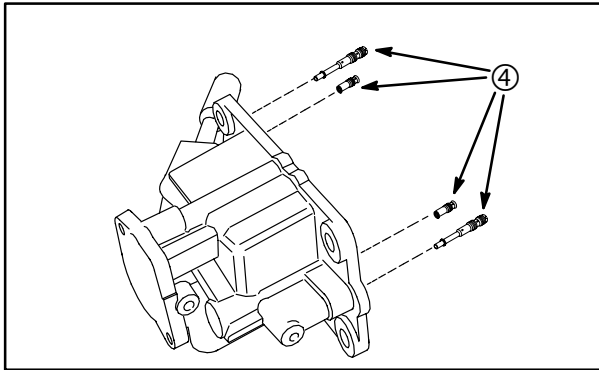
## Disassemble Carburetor

1. Remove four screws (1) and float bowl (2), **Fig. 130**. Discard gasket.
2. Use **13 mm** thin profile wrench to remove fuel solenoid (3) from float bowl. Discard gasket.



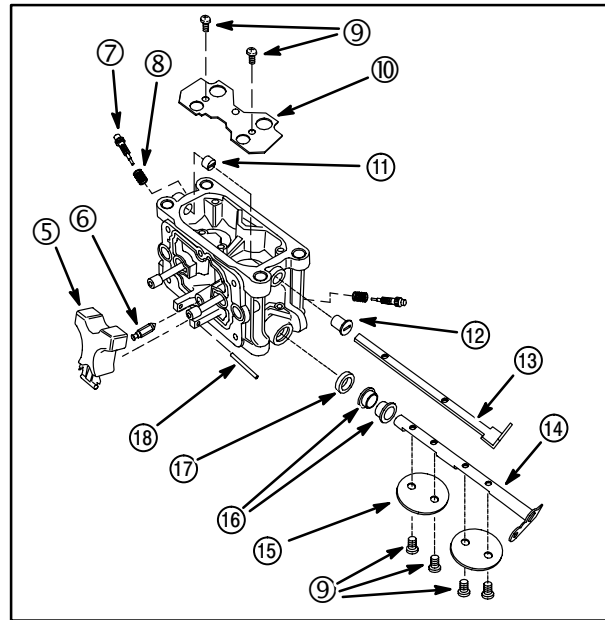
**Fig. 130**

3. Remove main jets (4) from float bowl, **Fig. 131**.



**Fig. 131**

4. Remove float hinge pin (18), float (5) and inlet needle (6) from carburetor body, **Fig. 132**.
5. Remove limiter caps (8) and mixture adjustment screws (7).
6. Remove screws (9) and choke plate (10).
7. Remove choke shaft (13) and bushings (11, 12) from carburetor body.
8. Mark throttle plates (15) before removal so they will be re-installed in the original position. Sides of throttle plate are beveled.
9. Remove screws (9), throttle plates and throttle shaft (14) with bushings (16) and seal (17). Discard seal.





**Fig. 132**

This completes the carburetor disassembly procedure.


## Clean Carburetor

1. Disassemble carburetor.
2. Remove and discard all old gaskets, seals and sealing material.

	 <b>CAUTION</b>
	<b>AVOID INJURY!</b>
<ul style="list-style-type: none"> <li>• Wear suitable protection when using cleaners. Follow instructions on container.</li> </ul>	

3. Use a commercial carburetor cleaner such as Briggs & Stratton Spray Cleaner **#100041** or **#100042** to clean carburetor parts and body.

**NOTE:** Parts containing rubber, such as seals, O-rings, inlet needles, seats or pump diaphragms should not be placed in commercial carburetor cleaner. Do not leave non-metallic parts (plastic, nylon, Minlon™, etc.), in commercial carburetor cleaner more than 15 minutes.

	<p style="text-align: center;"><b>CAUTION</b></p>
<p><b>AVOID EYE INJURY!</b></p>	
<ul style="list-style-type: none"> <li>• Wear eye protection when using compressed air.</li> </ul>	

4. Use only compressed air (blowing in both directions) to clean out all openings and passages.

**NOTE:** Do not use wire, drills or other mechanical devices to clean out metering holes or passages.

### **Inspect Carburetor**

Inspect all parts for wear, cracks, nicks and burrs. Inspect float for leaks. Replace damaged or worn parts.

### **Assemble Carburetor**

Use new seals and gaskets when assembling carburetor.

1. Assemble new seal and bushings to throttle shaft. Insert into carburetor body.

**NOTE:** Install one throttle plate at a time. Check throttle for freedom of operation before installing other throttle plate.  
Use LOCTITE® 222 on screw threads.

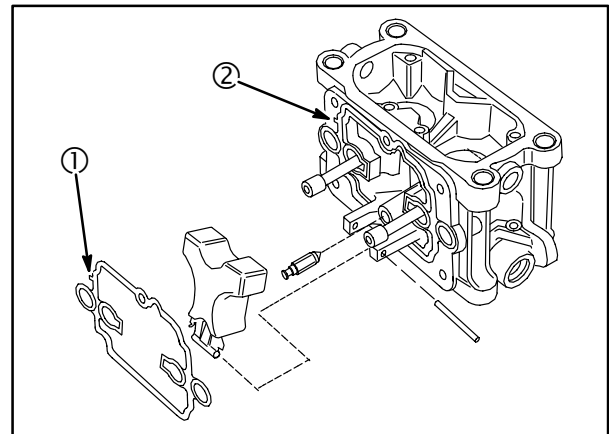
2. Insert bushings and choke shaft into carburetor body.
3. Install choke plate.

**NOTE:** Use LOCTITE® 222 on screw threads.

4. Assemble inlet needle to float. Install float, **Fig. 133**.

5. Assemble bowl gasket to groove in body.

**NOTE:** The tab on the float bowl gasket (1) goes in the slot in the float bowl carburetor body (2).



**Fig. 133**

6. Install the carburetor jets to the float bowl.

7. Install the float bowl assembly to the carburetor body.

**NOTE:** The float hinge pin is not secured in the hinge pin posts. Be sure the hinge pin remains in the posts until the float bowl is installed.

8. Assemble fuel solenoid to float bowl.

**CAUTION:** Do not damage the float bowl when tightening the solenoid. Do not overtighten.





# Section 5

## Governor

---

	Page
GENERAL INFORMATION .....	114
GOVERNOR CONTROLS .....	114
GOVERNORS .....	114
All Models – Except 540000, 610000 .....	114
Models 540000, 610000 .....	117

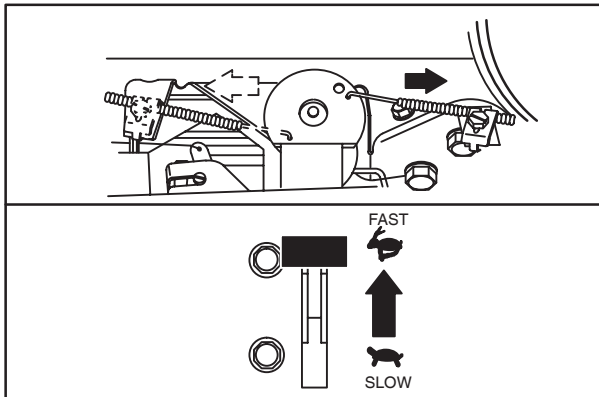
## GENERAL INFORMATION

**NOTE:** See Section 2 for Performance Control™ electronic governor service information.

Vanguard™ OHV V-Twin engines may be equipped for remote control, manual friction, or fixed speed adjustable governor controls.

### Remote Control and Manual Friction

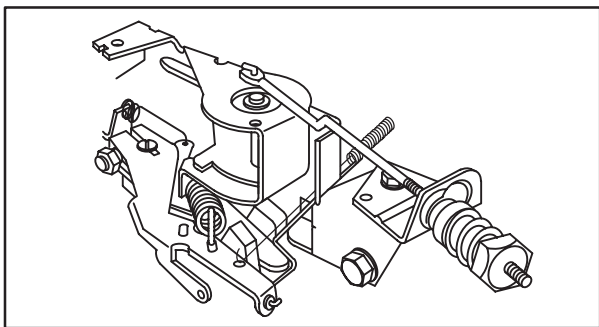
Remote governor controls (supplied by the OEM) and manual friction governors (mounted on the engine) control engine speed by increasing or decreasing tension on the governor spring(s) to obtain the desired engine speed. Both controls, **Fig. 1**, provide speed control at all positions.



**Fig. 1**

### Fixed Speed Adjustable

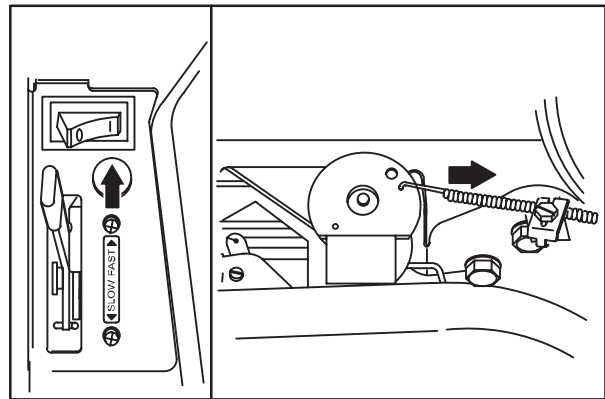
The fixed speed adjustable governor, **Fig. 2** is used in applications where a constant speed is required, such as generator applications.



**Fig. 2**

### Governed Idle

OHV V-Twin engines equipped for manual friction or remote control have a governed idle system, **Fig. 3**. A throttle restrictor maintains the engine speed when a load is applied and the equipment control is in the SLOW position.



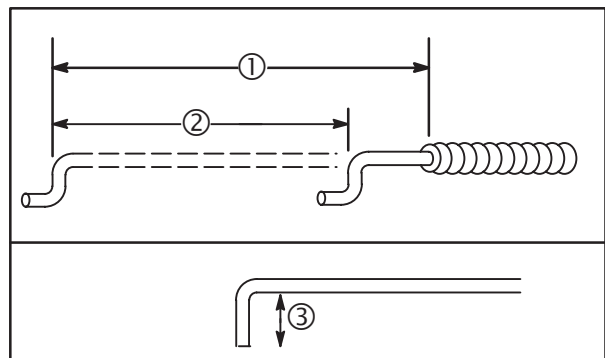
**Fig. 3**

## GOVERNOR CONTROLS

### Remote Control Wire Travel

In order to make proper remote control adjustments, the remote control wire must have travel of **not less than 1-3/8" (35 mm) (2)** with controls mounted in equipment, **Fig. 4**. The dimension from the end of the cable casing to the wire at the end of its travel (1) is **2-1/8" (54 mm) minimum**.

Some control brackets are equipped with a plastic swivel for the control wire. The control wire has a 90° bend and snaps into the swivel. The length of the bend (3) should not exceed **1/4" (6 mm)**.



**Fig. 4**

## GOVERNORS

### All Models – Except 540000, 610000

#### Disassembly

Drain oil and remove engine from equipment. Remove spark plugs. Remove valve covers. Compress valve springs and remove push rods.

1. Disconnect governor link and spring (1) at carburetor, **Fig. 5**.
2. Disconnect governed idle spring (4, if equipped).

- Loosen governor lever nut (3).
- Remove governor lever (2) from shaft.

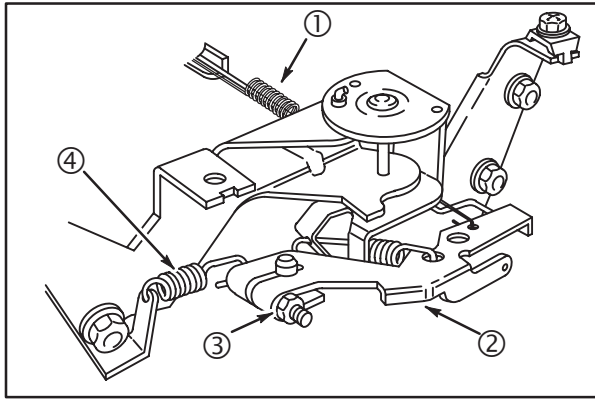


Fig. 5

- Remove rust, nicks or burrs from crankshaft.
- Remove oil fill tube and dipstick assembly.
- Remove crankcase cover, Fig. 6.
- Discard gasket and O-ring.

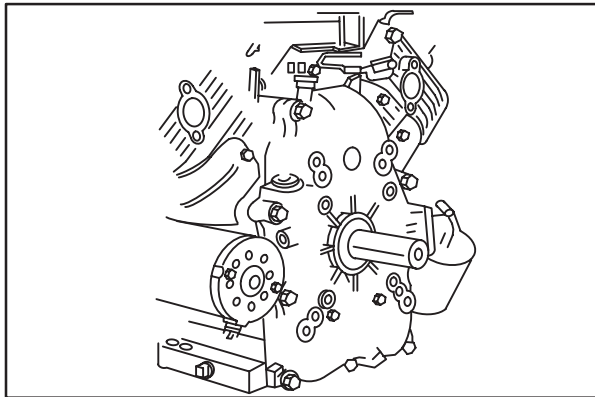


Fig. 6

### Inspect Governor

- Governor spool (3) must move freely on PTO journal of camshaft, Fig. 7. Replace if spool sticks or bearing is damaged.
- Flyweights (2) must move freely on hinge pins (1). Replace camshaft if hinge pins are loose or governor spool does not move freely on journal.

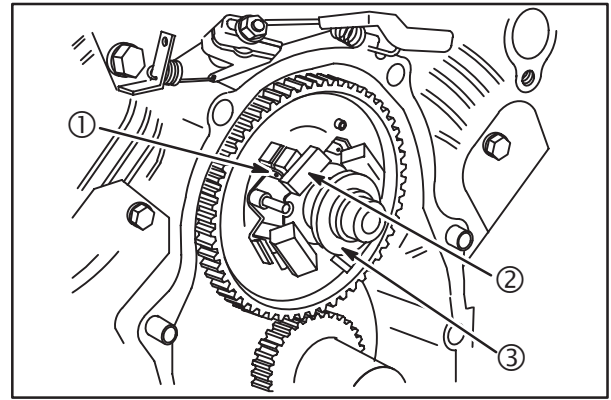


Fig. 7

### Remove Governor Shaft

- Remove cotter pin (3) and collar (2). Discard cotter pin, Fig. 8.
- Slide governor shaft (1) out of bushings (5).
- Remove and discard seal (4).
- Check governor shaft and bushings for wear or damage.

Replace as required.

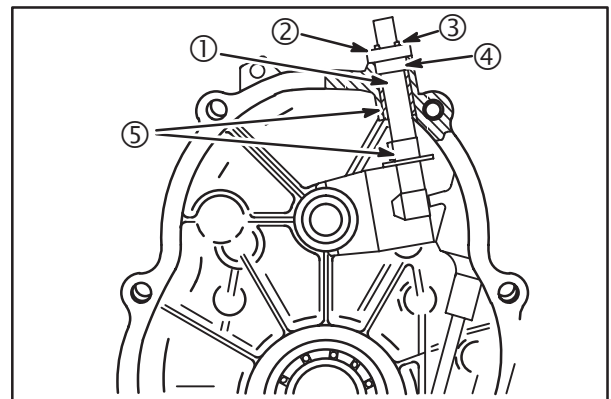


Fig. 8

### Replace Governor Shaft Bushings

- Press out upper bushing (2) using Bushing Driver #19204 (1), Fig. 9.
- Lubricate new bushing with engine oil. Press in place with Bushing Driver #19204.

**NOTE:** Lower bushing is a slip fit. If bearing for lower bushing (3) is worn, the crankcase cover must be replaced.

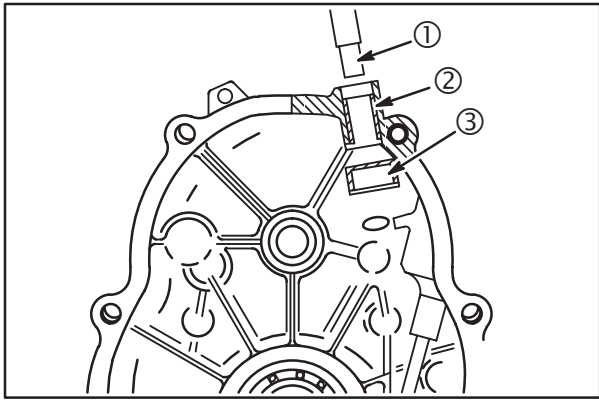


Fig. 9

### Install Governor Shaft

1. Assemble lower bushing to governor shaft with thrust flange (4) down, **Fig. 10**.
2. Slide shaft up through lower bearing and upper bushing.
3. Install new seal (3), collar (1) and cotter pin (2). Governor shaft must rotate freely.
4. Rotate governor shaft (arrow) so that paddle rests against camshaft bearing support (5).

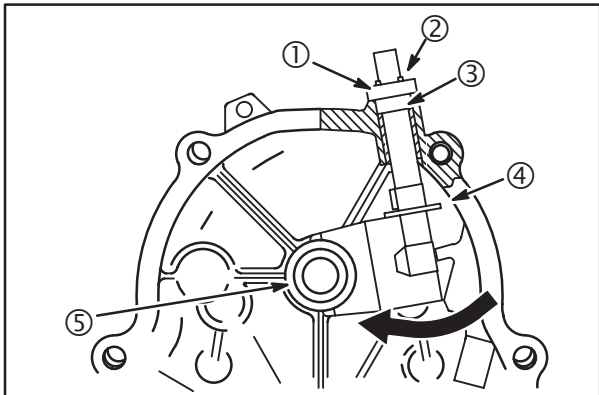


Fig. 10

### Assembly

1. Assemble governor spool to camshaft, **Fig. 11**.
  - a. Make sure that spool (2) engages flyweights and slot on spool fits over locating pin (1).
  - b. Install new O-ring (3) in cylinder.

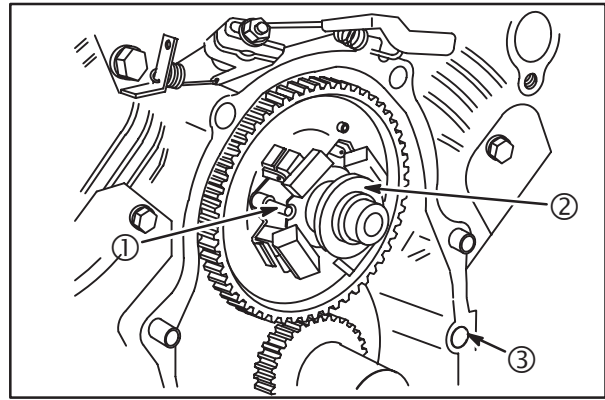


Fig. 11

2. Insert proper seal protector through oil seal.
3. Install crankcase cover or sump with new gasket. Torque screws in sequence shown to **150 in. lbs. (17 Nm)**, **Fig. 12**.
4. Reinstall oil fill tube and dipstick assembly.

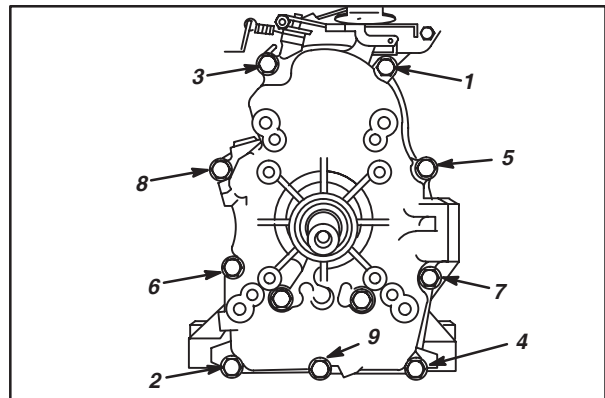


Fig. 12

5. Reassemble governor lever (6) to shaft, **Fig. 13**.
  - a. Reassemble governor link and spring (5) at carburetor.
  - b. Reassemble governed idle spring (4).

**NOTE:** DO NOT tighten nut (7) at this time.

6. Install push rods in their original position.
7. Compress valve spring with rocker arm. Insert push rod into rocker arm socket. Be sure push rods remain seated in recess in tappets.
8. Install valve covers with new gaskets and valve cover seals. Torque nuts to **25 in. lbs. (3 Nm)**.

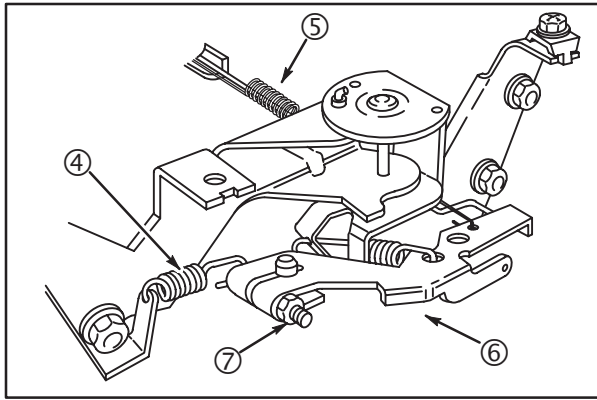


Fig. 13

9. Perform governor adjustments, see Troubleshooting, Section 2.

	<b>WARNING</b>
	<p>Static adjustment of the governor must be completed <b>BEFORE</b> starting or running engine!</p>
<ul style="list-style-type: none"> <li>• Failure to make static governor adjustments first could result in engine overspeeding and consequential engine damage, property damage or personal injury.</li> </ul>	

## Models 540000, 610000

### Disassemble Governor Gear

The governor gear (1) is located on the inside of the crankcase cover, Fig. 14.

Drain oil and remove engine from equipment. Remove spark plugs. Remove crankcase cover.

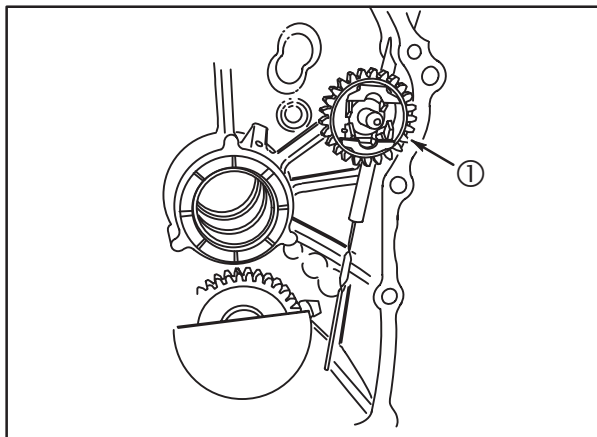


Fig. 14

1. The governor gear should spin freely and slide on the governor gear shaft. The flyweights (2), Fig. 15, must move freely on the hinge pins.

2. If necessary, remove the governor gear (1) from the crankcase cover with two screwdrivers (3). Remove the washer from under the governor gear.

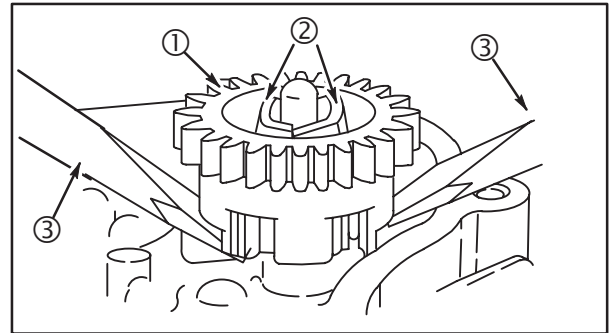


Fig. 15

### Inspect Governor Gear

1. Check the governor gear assembly for worn weights or weight pins. Inspect the governor cup, washer and gear for wear or damage.
2. Inspect the governor gear shaft (1) for wear or damage, Fig. 16.

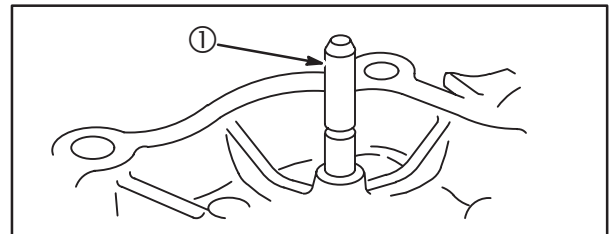


Fig. 16

Replace the crankcase cover if the shaft is worn, bent or otherwise damaged.

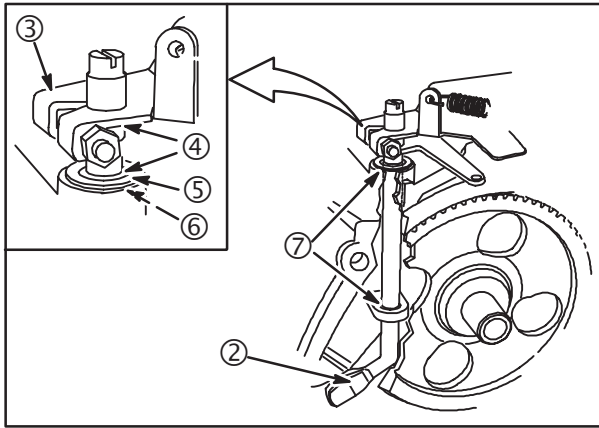
### Install Governor Gear

1. Install the washer and governor gear to the governor gear shaft.
2. Secure the governor gear assembly to the shaft with the retaining clip.
3. Place governor gear cup into the governor gear weights and push down into position on the governor gear shaft.

### Remove Governor Crank

1. Inspect the governor crank (2) for wear or damage, Fig. 17.

**NOTE:** Camshaft gear and cylinder block are cut away for clarity.



**Fig. 17**

2. If necessary remove the crank from the cylinder block. Mark the governor lever and the governor crank to aid in reassembly. Remove the governor lever from the crank (3). Remove the upper and lower retaining rings (4) and the washer (5). Slide the crank out of the bushings (7).

3. Replace the oil seal (6, under the washer). Replace worn or damaged components.

**NOTE:** Inspect the crank and the crank bushings. If the bushings are damaged or worn replace the cylinder block.

#### **Install Governor Crank**

1. Insert the governor crank through the crank bushings and new seal. Install the washer and lower retaining ring.
2. Install the upper retaining ring and the governor lever. Align the marks on the governor lever and the governor crank.

# Section 6

## Cylinder Heads and Valves

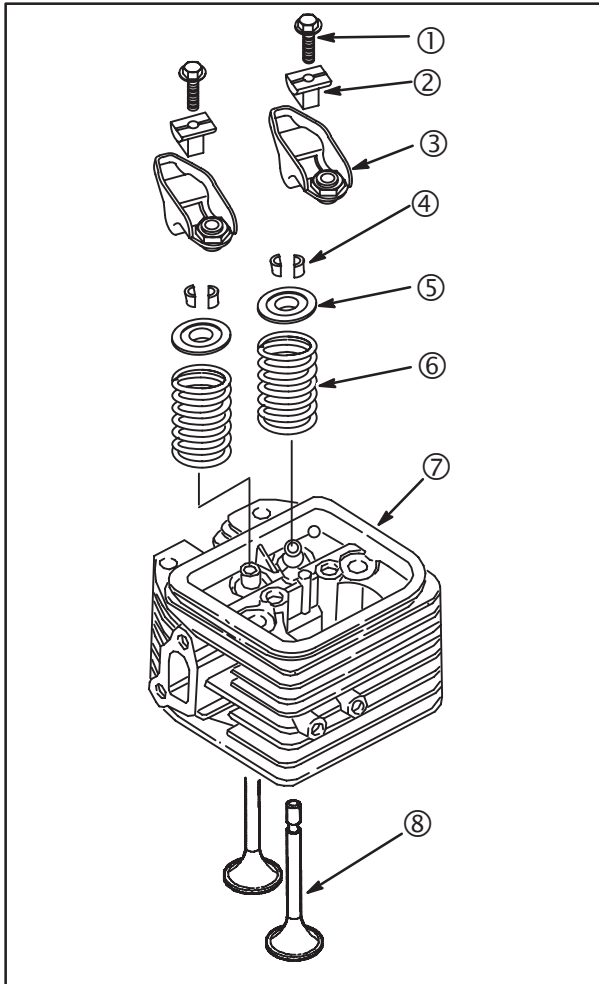
---

	Page
<b>CYLINDER HEAD SERVICE</b> .....	<b>120</b>
<b>Remove Cylinder Head</b> .....	<b>120</b>
<b>Disassembly</b> .....	<b>121</b>
<b>Inspect and Repair</b> .....	<b>121</b>
<b>Assembly</b> .....	<b>123</b>
<b>Install Cylinder Head</b> .....	<b>124</b>
<b>Install Rocker Arms</b> .....	<b>124</b>
<b>Install Push Rods</b> .....	<b>124</b>
<b>PARTS IDENTIFICATION</b> .....	<b>120</b>



## PARTS IDENTIFICATION

Compression testing information and procedure is described in Section 2 – TROUBLESHOOTING. **Fig. 1** shows the components of a typical V-Twin OHV Cylinder Head.



**Fig. 1**

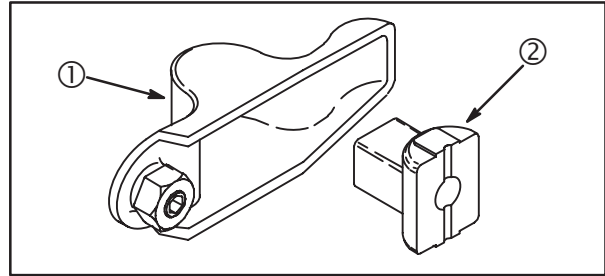
1. Screw
2. Rocker Arm Support
3. Rocker Arm
4. Valve Spring Retainer Locks
5. Valve Spring Retainer
6. Valve Spring
7. Cylinder Head
8. Valve

### Rocker Arm Identification

Three different rocker arms have been used.

**Style 3:** (Current) Engines manufactured after date code 960331xx are equipped with a redesigned cylinder head, and stamped steel rocker arms (1), **Fig. 2**, with a separate rocker arm support (2) for

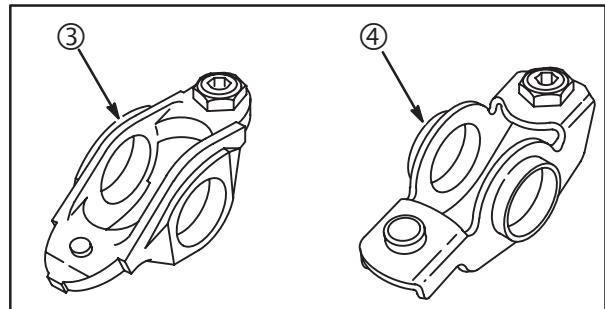
each valve. The redesigned cylinder head, gasket and rocker arm assembly will not interchange with previous cylinder heads. The new cylinder head may be used on earlier V-Twins, but only as a complete assembly. Refer to date code when ordering parts.



**Fig. 2**

**Style 2:** Engines manufactured before 960401xx but after 931031xx are equipped with cast aluminum rocker arms (3) with a rocker arm shaft, **Fig. 3**.

**Style 1:** Engines manufactured before date code 931101xx were equipped with stamped steel rocker arms (4) with a rocker arm shaft, **Fig. 3**.



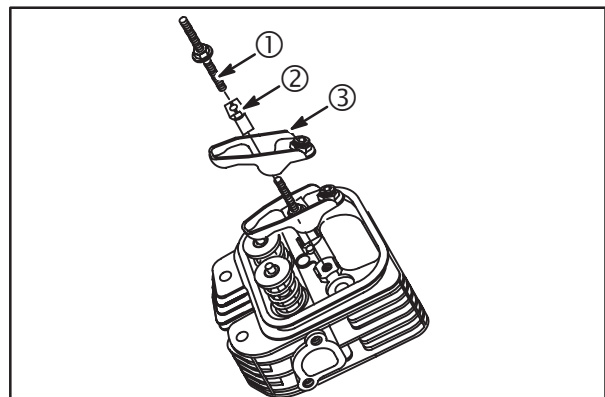
**Fig. 3**

## CYLINDER HEAD SERVICE

### Remove Cylinder Head

1. Remove two rocker studs (1) supports (2) and rocker arm assemblies (3), **Fig. 4** (current) or **Fig. 5** (early). Remove rocker arm shaft (4, early versions).
2. Remove push rods.

**NOTE:** Label push rods for reassembly in the original location.



**Fig. 4**

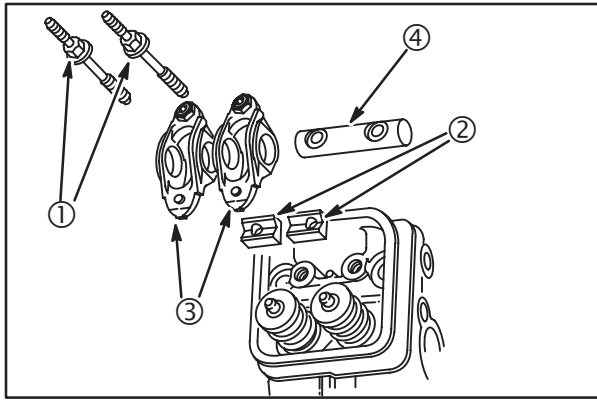


Fig. 5

- Remove head bolts (5, 6, 7, 8) and cylinder head, Fig. 6. Discard cylinder head gasket.

**NOTE:** Engines manufactured before 940501xx were equipped with sealing washers under cylinder head bolts (5) and (6).

Repeat for other cylinder head.

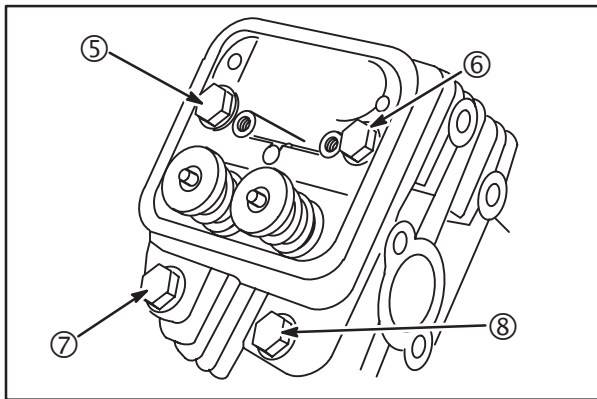




Fig. 6

### Disassembly

- Thread rocker arm support screw into cylinder head a few turns.

	 <p><b>CAUTION</b></p>
<p><b>PREVENT EYE INJURY!</b></p>	
<ul style="list-style-type: none"> <li>• WEAR EYE protection when using Valve Spring Compressor.</li> </ul>	

**NOTE:** Place a shop rag or short section of rubber fuel line under valves inside combustion chamber to hold valve in place while compressing spring.

- Compress valve spring and retainer with Valve Spring Compressor (3) #19347, Fig. 7.
- Remove valve spring retainer locks (2).
- Gradually release pressure on the valve spring compressor. Remove valve spring retainer and valve spring.

- Remove intake and exhaust valves.

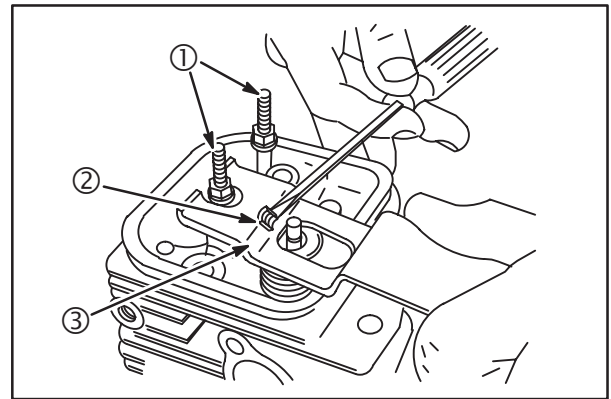


Fig. 7

- Remove and discard valve stem seals, Fig. 8.

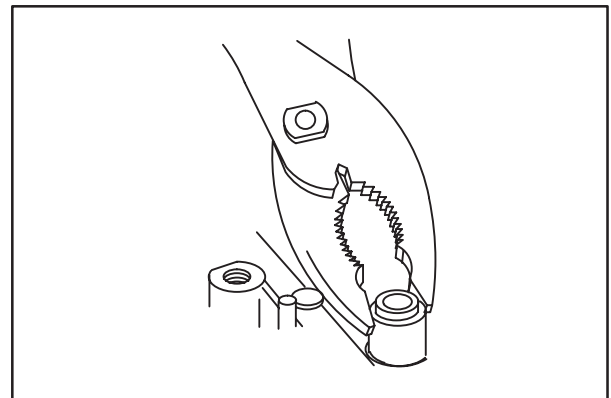


Fig. 8

### Inspect and Repair

- Check cylinder head, Fig. 9.

**NOTE:** Be sure all gasket material is removed from surfaces before checking. Use a gasket scraper if necessary.

- Inspect cylinder head for cracks or damage.
- Use a surface plate or straight edge (1) and check cylinder head mounting surface for distortion.

Replace the cylinder head if the mounting surfaces are distorted more than **0.004" (0.1 mm)**.

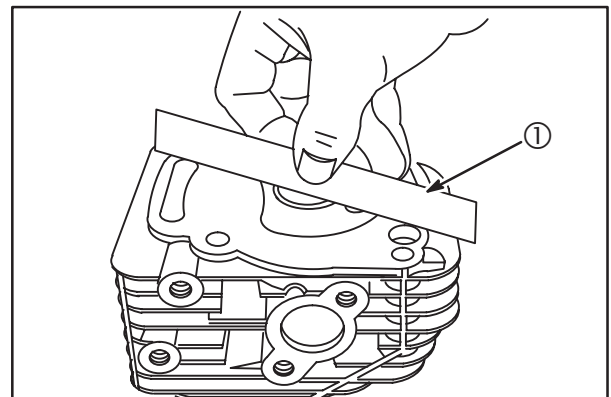


Fig. 9

• **CAUTION:** Do not resurface cylinder head mounting surfaces.

2. Check valve guide bushings for wear using Plug Gauge (2) #19382, Fig. 10. Replace valve guide if gauge enters guide 1/4" (6 mm) or more.

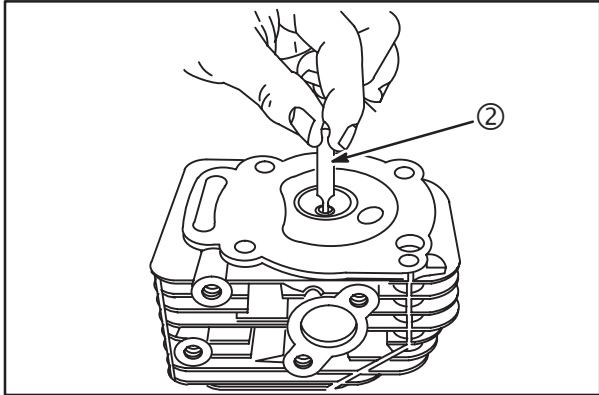


Fig. 10

### Replace Valve Guide

1. Press out old valve guide (2) using Bushing Driver (1), #19367, Fig. 11.

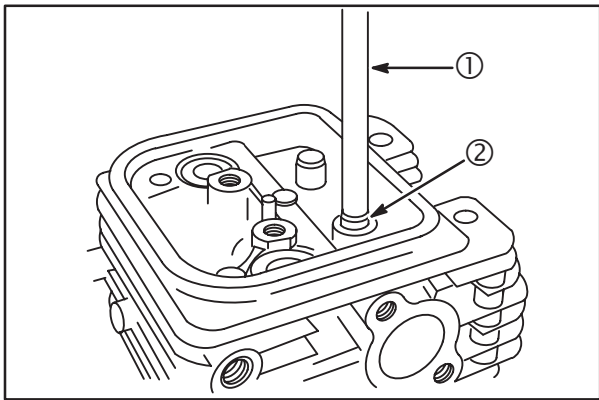


Fig. 11

2. Press in new valve guide (4) using Bushing Driver (3) #19416, Fig. 12. Press in until tool bottoms on valve guide bushing boss.

• **CAUTION:** Do not use hammer to install bushing.

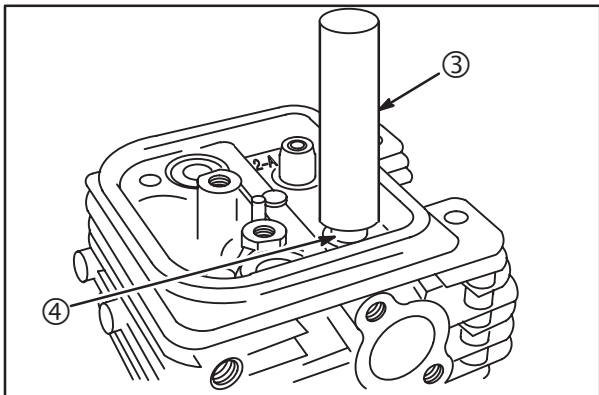


Fig. 12

3. Use Reamer Pilot Guide #19345 (5) and Finish Reamer #19444 (6) to ream new valve guide, Fig. 13.
  - a. Use Stanisol® or kerosene to lubricate reamer.
  - b. Ream through entire guide.
  - c. Keep turning reamer CLOCKWISE when removing reamer.
  - d. Flush out all chips.

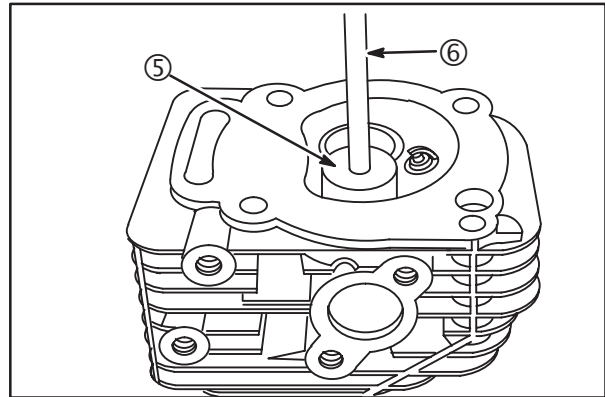


Fig. 13

### Reface Valves And Seats

Valve seats can be reconditioned with Valve Seat Cutter Kit #19237 and #19343.

If valve seat is wider than 3/64" (1.2 mm), Fig. 14, use a narrowing cutter to ensure that contact area of valve seat is centered on face of valve, Fig. 16.

Use a 60° cutter, Fig. 14, top inset, to narrow seat from bottom. Use a 15° cutter, Fig. 14, bottom inset, to narrow seat from top.

**NOTE:** If valve seat is loose or cracked, replace cylinder head.

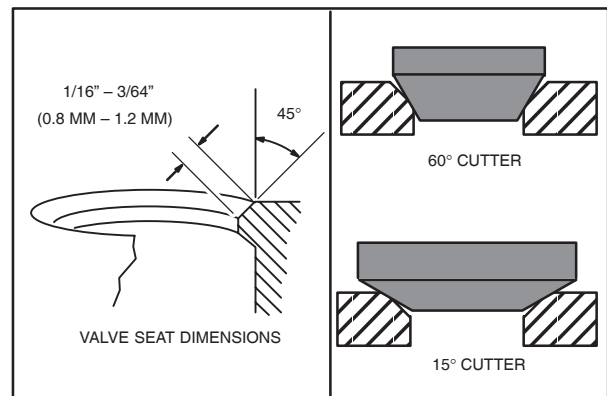
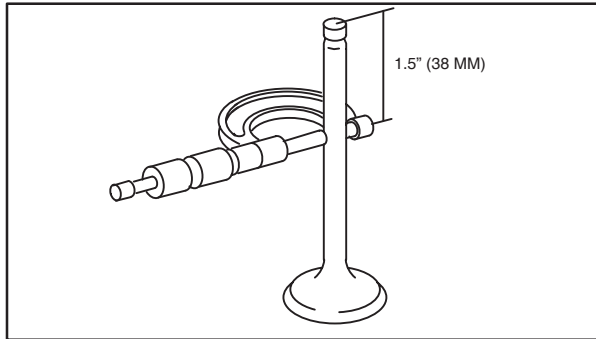


Fig. 14

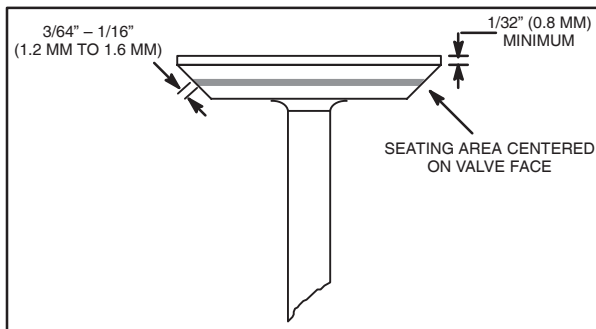
1. Measure valve stem diameter approximately **1-1/2" (38 mm)** from end of valve, **Fig. 15**.  
Replace valve if stem diameter is less than **0.233" (5.92 mm)**.



**Fig. 15**

2. Valve faces can be resurfaced to **45°**. See **Fig. 16** for dimensions for valves.
3. Lap the valves and seats with Valve Lapper **#19258** and Valve Lapping Compound **#94150**.

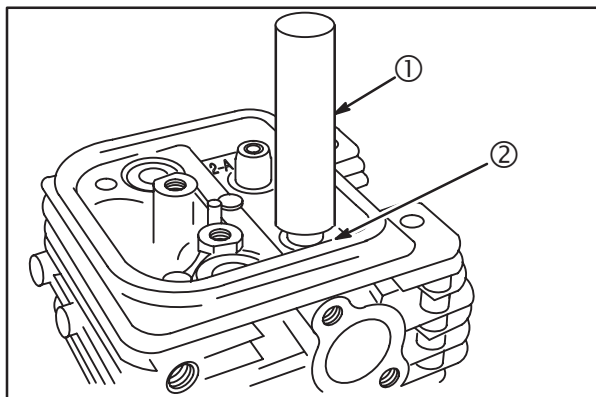
**NOTE:** In most instances it is more economical to replace the valves than to reface them.



**Fig. 16**

## ASSEMBLY

1. Use Valve Guide Driver (1) **#19416** to install new valve stem seals (2), **Fig. 17**.
  - a. Oil inner surface and lip of valve stem seal.
  - b. Press seal on to valve guide bushing until it bottoms.

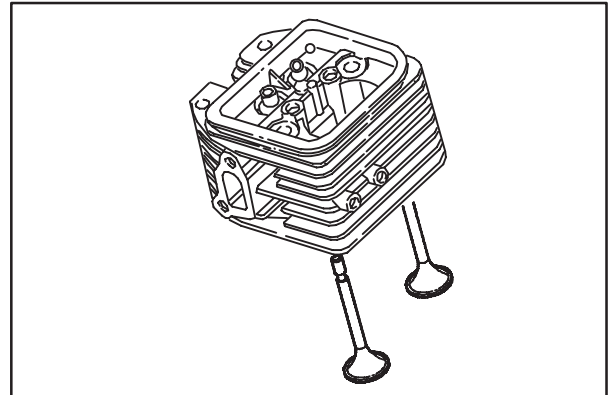


**Fig. 17**

2. Install valves, **Fig. 18**.

**NOTE:** Lightly coat valve stems with Valve Guide Lubricant **#93963** before installing valves. Be sure valve guide lubricant is not on valve face, seat or end of valve stem.

3. Install springs and valve spring retainers over valve stems.

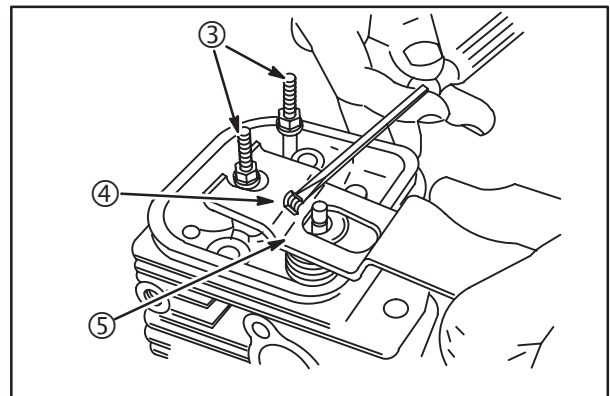


**Fig. 18**

**NOTE:** Place a shop rag or short section of rubber fuel line under valves inside combustion chamber to hold valve in place while compressing spring.

	<b>CAUTION</b>
	<b>PREVENT EYE INJURY!</b>
<ul style="list-style-type: none"> <li>• Wear eye protection when using Valve Spring Compressor.</li> </ul>	

4. Temporarily install rocker studs (3) in cylinder head.
5. Compress valve spring and retainer with Valve Spring Compressor **#19347** (5). Install the valve retainer locks (4), **Fig. 19**.



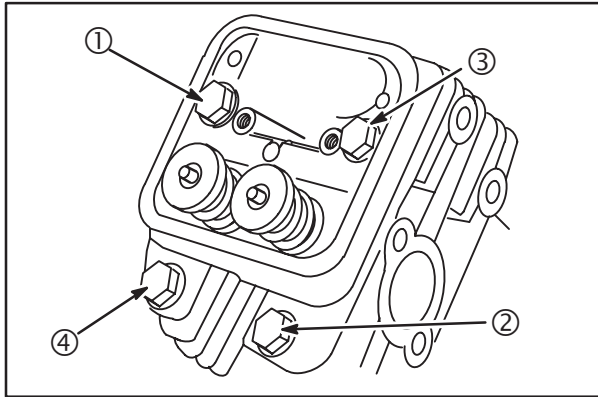
**Fig. 19**

6. Make sure the retainer locks are seated into the valve stem groove and valve retainer. Gradually release pressure on the valve spring compressor.

Repeat procedure for other valve. Remove rocker studs.

## Install Cylinder Heads

1. Install cylinder head with NEW gasket, **Fig. 20**.



**Fig. 20**

**NOTE:** Engines manufactured BEFORE 940501xx were equipped with sealing washers under #1 and #3 cylinder head bolts.

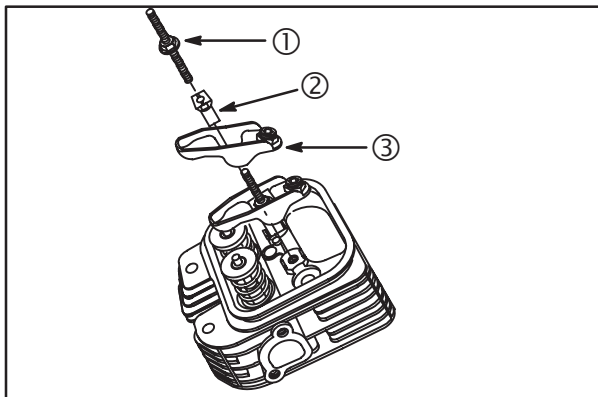
2. Lubricate threads of head bolts with Valve Guide Lubricant #93963.
3. Torque bolts in the sequence shown, **Fig. 20**, to **165 in. lbs. (19 Nm)**.

**NOTE:** Models 540000, 610000 torque to **350 in. lbs. (40 Nm)**.

## Install Rocker Arms

### Current Style

1. Lubricate rocker arm supports (2) with clean engine oil.
2. Assemble rocker studs (1), rocker arm supports and rocker arms (3) to cylinder head, **Fig. 21**. Torque studs to **100 in. lbs. (11 Nm)**.

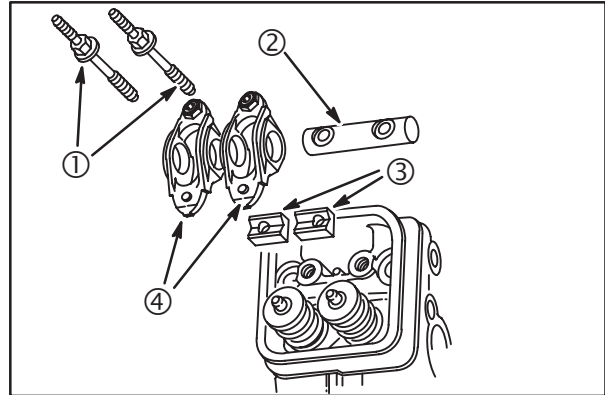


**Fig. 21**

### Early Style

**NOTE:** Rocker shaft support (3) holes are offset. Install with holes facing ends of rocker shaft, **Fig. 22**.

1. Lubricate rocker arms (4) and shaft (2) with clean engine oil.
2. Assemble rocker arms, shaft, supports and studs (1) and install on cylinder head, **Fig. 22**. Torque studs to **140 in. lbs. (16 Nm)**.



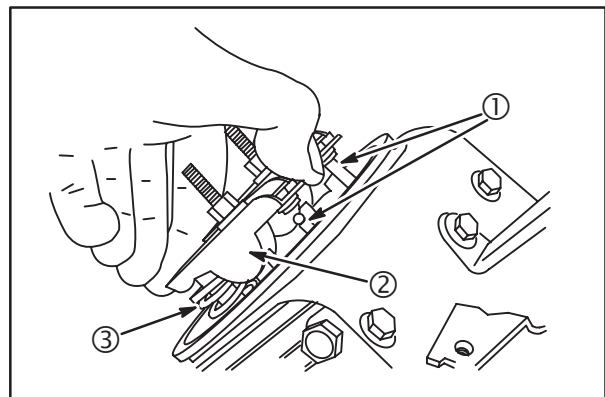
**Fig. 22**

## Install Push Rods

**NOTE:** All models **except 540000, 610000** – Exhaust valve push rods are aluminum. **Models 540000, 610000** – All push rods are aluminum.

1. Compress valve spring (3) with rocker arm (2) and insert push rod (1) into rocker arm socket, **Fig. 23**.

**NOTE:** Seat push rods into recess in tappets.



**Fig. 23**

2. Repeat for No. 2 cylinder.
3. Adjust valve clearance. See Section 1.

# Section 7

## Starters

---

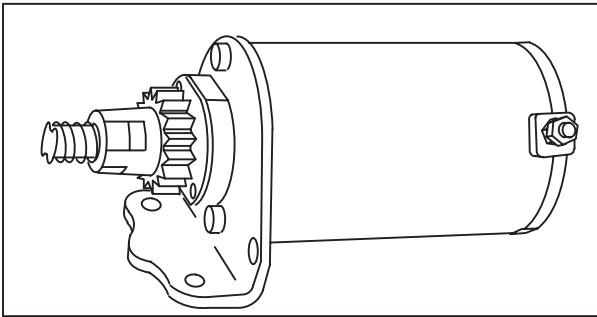
	Page
GENERAL INFORMATION .....	126
REWIND STARTER IDENTIFICATION .....	137
REWIND STARTER SERVICE .....	137
Remove Rewind Starter .....	137
Replace Rope .....	138
Replace Pulley and Spring – Current Style .....	139
Replace Pulley and Spring – Early Style .....	140
Install Rewind Starter .....	142
RING GEAR SERVICE .....	136
STARTER DRIVE SERVICE – Except Models 540000, 610000 .....	126
C-Ring Style .....	127
Roll Pin Style .....	127
Steel Pinion Style .....	128
STARTER MOTOR SERVICE – Except Models 540000, 610000 .....	128
Disassembly .....	128
Inspect Armature Commutator .....	129
Inspect Brushes .....	129
Replace Brushes .....	130
Assemble End Cap .....	130
Assemble Armature .....	131
Assemble Housing .....	131
Install Drive End Cap .....	132
STARTER MOTOR SERVICE – Models 540000, 610000 .....	132
Starter Solenoid .....	132
Pinion Gear .....	133

## GENERAL INFORMATION

The starter motor uses a gear engagement method, similar to an automotive starter. When the starter motor is activated, the pinion gear engages a ring gear attached to the engine flywheel and cranks the engine. Three starter motors are used on Vanguard™ V-Twin engines, **Figs. 1-3**.

### Nylon Pinion

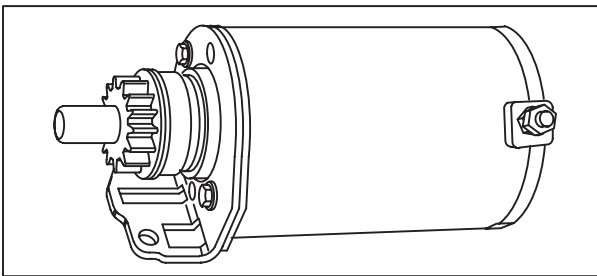
The starter motor shown in **Fig. 1** has a nylon pinion gear and is used only on flywheels equipped with an aluminum ring gear. These starters use either a C-ring or roll pin to retain the pinion gear. The flywheel ring gear is replaceable.



**Fig. 1**

### Steel Pinion

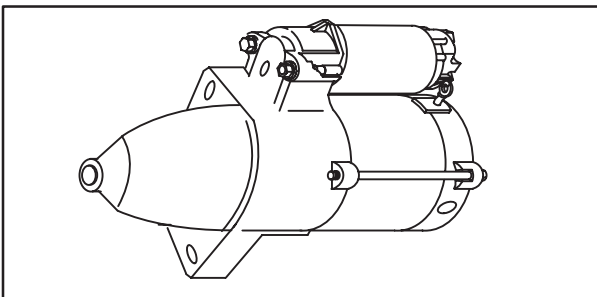
The starter motor shown in **Fig. 2** has a steel pinion gear and is used only with flywheels equipped with a steel ring gear. The flywheel ring gear is NOT replaceable.



**Fig. 2**

### Solenoid Shift

The starter motor in **Fig. 3** uses a solenoid to engage the flywheel, and is equipped with a steel ring gear. The flywheel ring gear is NOT replaceable.



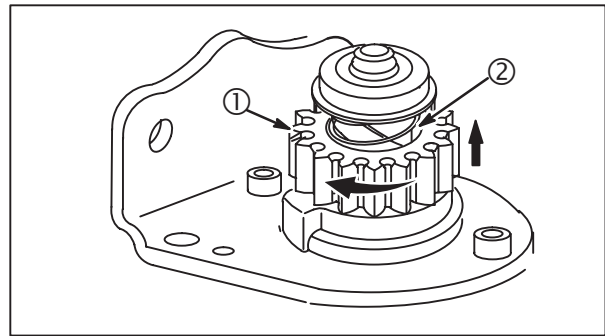
**Fig. 3**

## STARTER DRIVE SERVICE

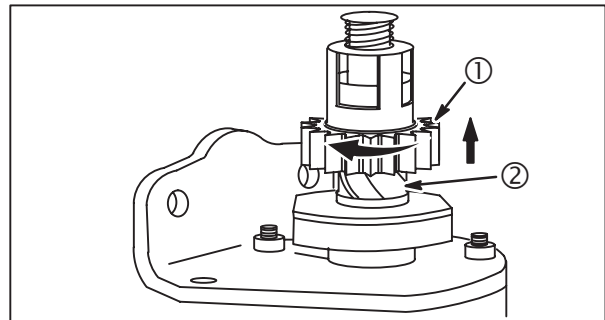
### *Except Models 540000, 610000*

The nylon pinion starter drives use either the C-ring retainer, **Fig. 4** or the roll pin retainer, **Fig. 5**. The steel pinion starter drive is shown in **Fig. 6**. When the starter motor is activated, the pinion gear should engage the flywheel ring gear and crank the engine. If it does not, inspect the helix and the pinion gear for freedom of operation.

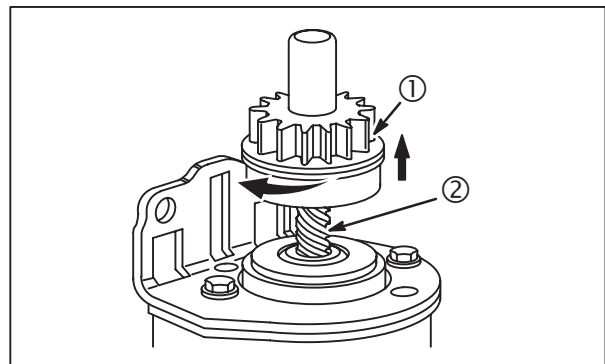
Inspect the pinion gear (1) for damaged teeth. The gear must move freely on helix (2), **Figs. 4, 5 or 6**.



**Fig. 4**



**Fig. 5**



**Fig. 6**

## C-Ring Style

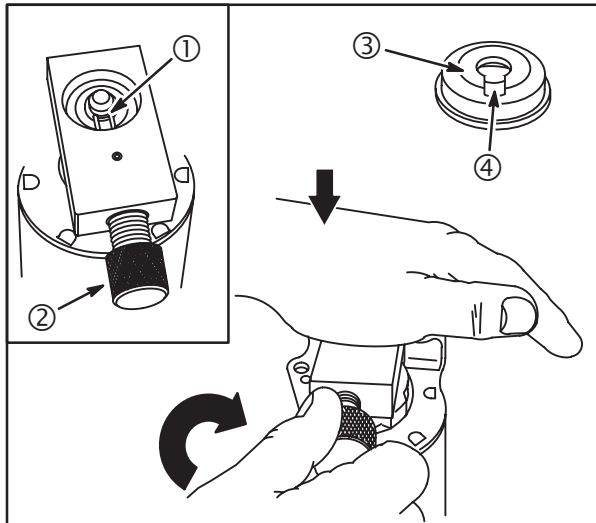
### Disassemble



1. Place the counterbored side of C-ring Remover #19436 (2) over retainer. Align drive pins (1) with open end of C-ring, **Fig. 7**.

**NOTE:** If retainer (3) has a notch (4) as shown, DO NOT align drive pins with notch. If necessary, rotate notch away from open end of C-ring.

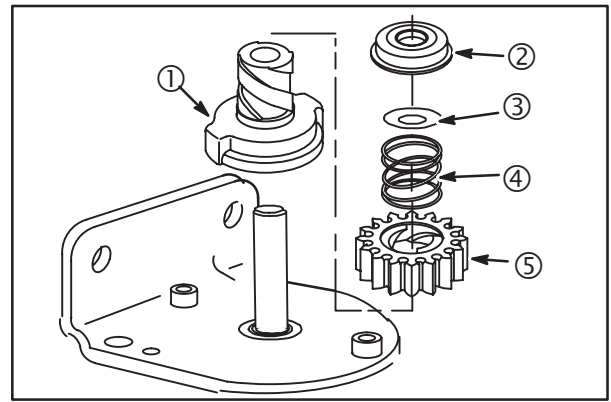
2. While applying pressure, turn knurled knob clockwise until C-ring pops off. Discard C-ring.
3. Remove retainer, return spring, spring washer, pinion gear, and starter clutch.



**Fig. 7**

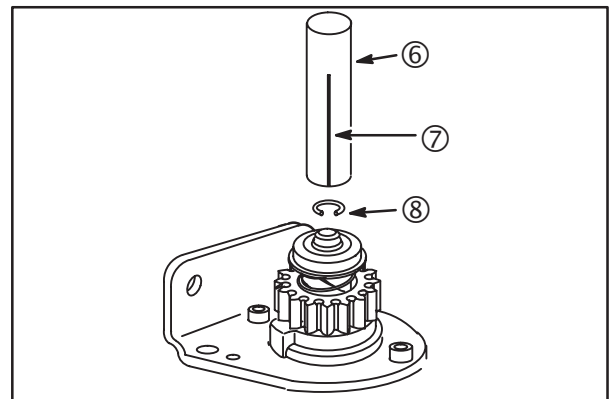
### Assemble

1. Assemble clutch drive (1) to starter shaft. Rotate clutch until it drops into place, **Fig. 8**.
2. Install pinion gear (5) with beveled side of teeth up. Then install return spring (4) making sure spring is in recess of starter gear.
3. Install spring washer (3) with concave side up. Install retainer (2).



**Fig. 8**

4. Place C-ring (8) over chamfered end of shaft. Align one of the slots (7) of C-ring Installer #19435 (6) with open end of C-ring, **Fig. 9**.
5. Press or drive C-ring on until it snaps into groove in shaft.



**Fig. 9**

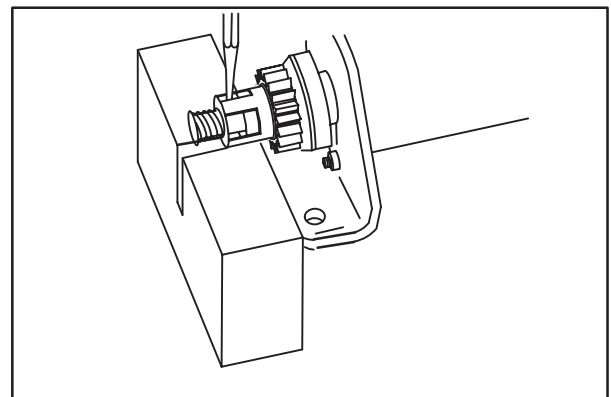
## Roll Pin Style

### Disassemble

1. Place starter drive retainer on support block, **Fig. 10**.

**NOTE:** See Section 13, Appendix, for support block dimensions.

2. Drive out roll pin with a 5/32" (4 mm) pin punch. Discard roll pin.
3. Remove retainer, washer, pinion gear, and starter clutch.



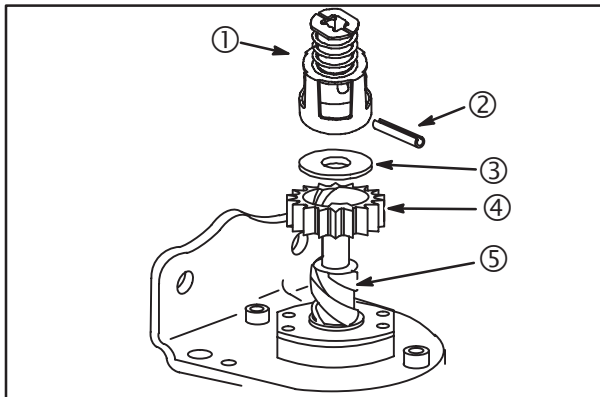
**Fig. 10**



## Assemble

1. Assemble clutch drive (5) to starter shaft. Rotate clutch until it drops into place, **Fig. 11**.
2. Install pinion gear (4) with beveled side of teeth UP.
3. Install washer (3) and retainer (1).
4. Install NEW roll pin (2).

**NOTE:** Slot in roll pin should face up.



**Fig. 11**

7

## Steel Pinion Style

### Disassemble

1. Grasp end of rubber dust cover (1) and pull to remove, **Fig. 12**.
2. Push down on upper spring retainer (3) to expose retaining ring (2) on shaft.
3. Use a small screw driver and pry off retaining ring. Discard retaining ring.
4. Remove upper spring retainer, spring (4), lower spring retainer (5), pinion gear (6) and clutch (7).

### Inspect

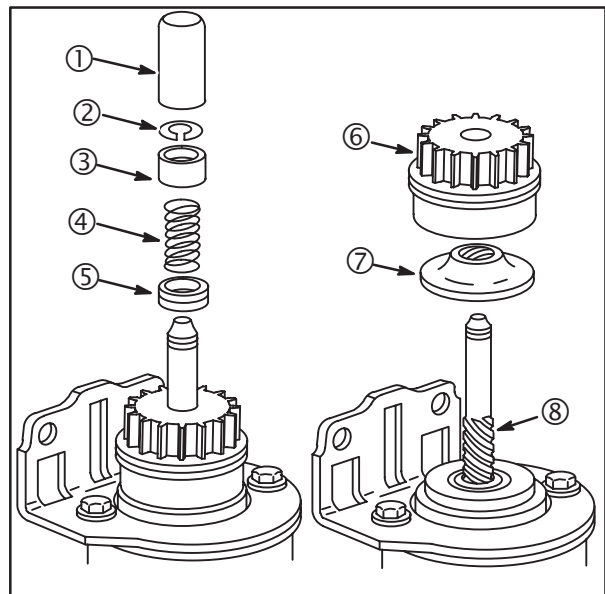
Check pinion gear for damaged or worn teeth. Rubber bottom of pinion is part of clutch. Check for wear or damage. Check clutch for wear.

If clutch rubber inside of pinion gear is worn or damaged, pinion gear will slip when starter is engaged.

### Assemble

1. Lubricate helix (8) with a light coat of grease.
2. Assemble clutch and pinion gear to shaft.

3. Assemble lower spring retainer with OPEN END UP.
4. Install spring.
5. Install upper spring retainer with OPEN END UP.
6. Compress spring. Install NEW retaining ring to shaft.
7. Compress retaining ring with pliers to ensure that it is seated properly in groove in shaft.
8. Pull up on upper spring retainer until retaining ring snaps into groove in upper spring retainer.
9. Push dust cover down until it snaps into groove in lower spring retainer.



**Fig. 12**

## STARTER MOTOR SERVICE

*Except Models 540000, 610000*

### Disassemble

**CAUTION:** DO NOT clamp motor housing in a vise or strike with a hammer. Starter motors contain ceramic magnets that could be broken or cracked if the housing is damaged.

The disassembly and inspection procedure of the two starter motors is similar. Where a procedure or specification is different, those differences will be shown. See **Fig. 13** (radial compression brush spring) or **Fig. 14** (axial compression brush spring) for exploded view of the two starter motors. Scribe a mark on drive end cap and starter housing for alignment purposes when reassembling.

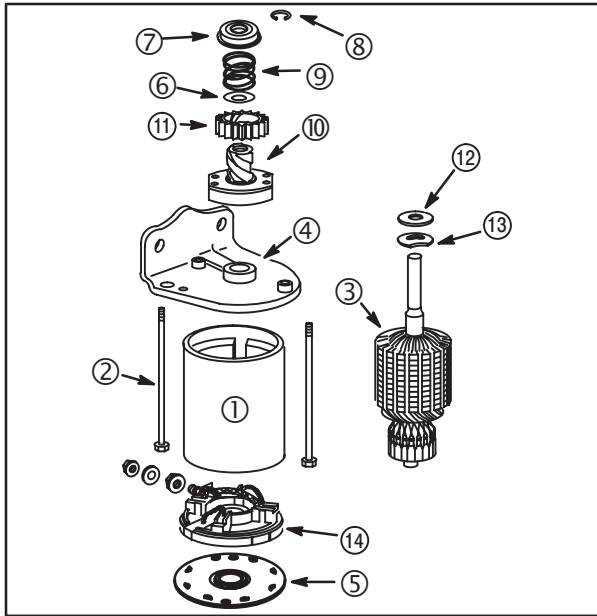


Fig. 13

1. Remove pinion gear assembly.
2. Remove thru bolts (2) and drive end cap (4).

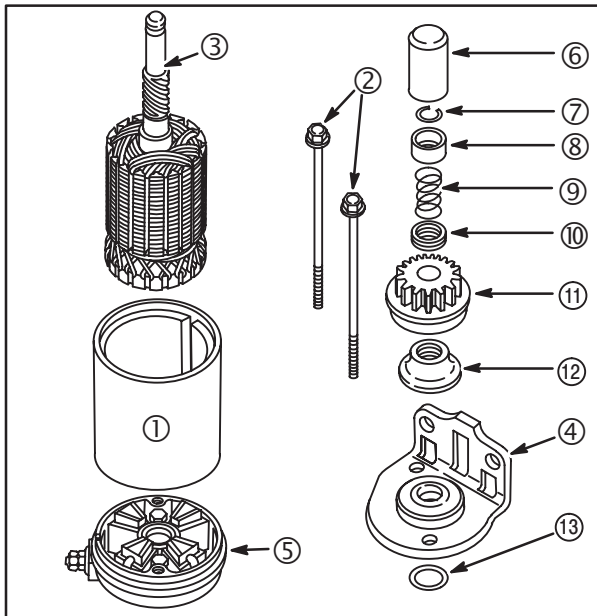


Fig. 14

3. Hold the armature (3) and commutator end cap (5) against a work surface while sliding housing (1) off the armature, Fig. 15.

**NOTE:** This allows the brush retainer to remain assembled to commutator for inspection of brush-to-commutator contact.

4. Remove end cap and brush retainer with brushes. Replace end cap if bushing is worn or damaged.

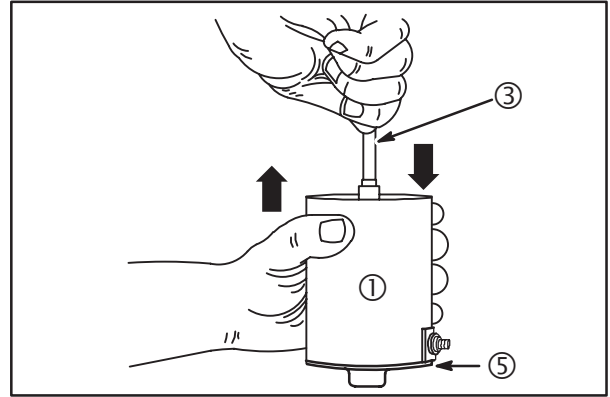


Fig. 15

### Inspect Armature Commutator

The armature commutator shown in Fig. 16 (A) can be cleaned with fine sandpaper. DO NOT use emery cloth. The commutator can be machined a diameter of NO LESS THAN 1.230" (31.24 mm).

Slots between commutator bars should be cleaned as shown in Fig. 16 (A) after sanding or machining.

Check the armature for shorts with a growler.

**NOTE:** The style armature commutator shown in Fig. 16 (B) cannot be machined.

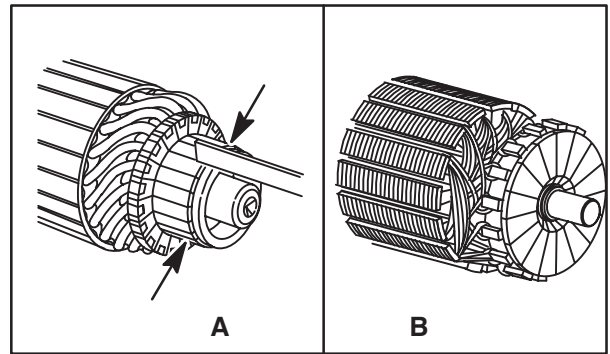


Fig. 16

### Inspect Brushes

Check the brushes for proper seating, weak brush springs, dirt, oil or corrosion. Brush springs should be strong enough to ensure good brush contact with armature. Replace the brushes if worn to 1/4" (6 mm) (1) or less Fig. 17 (A), or 1/8" (3 mm) (2) or less, Fig. 17 (B). Lengths of new brushes (3) are shown for reference.

Verify that the brushes are not sticking in their holders.

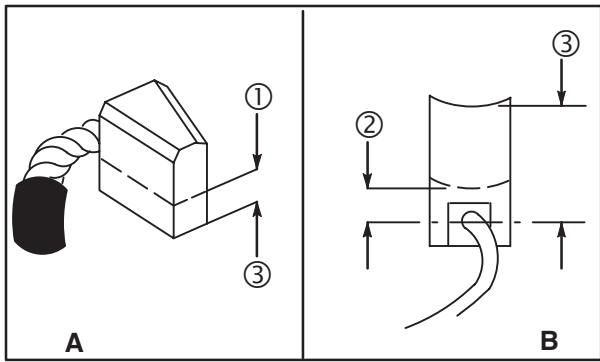


Fig. 17

## Replace Brushes

Three different brush end caps are used. Refer to Fig. 18 for radial flat coil spring end caps.

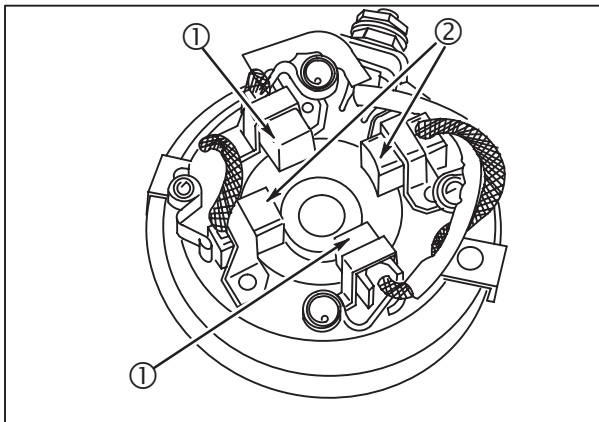


Fig. 18

Refer to Fig. 19 for radial compression spring end caps.

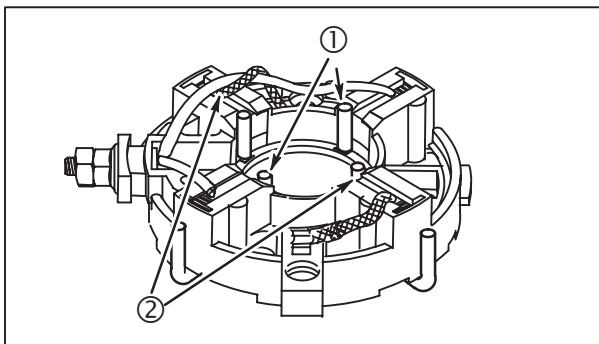


Fig. 19

Refer to Fig. 20 for axial compression spring end caps and for the correct location of positive brushes (1), negative brushes (2), brush leads and wire routing. Note order of assembly for insulators, washers and screws or nuts.

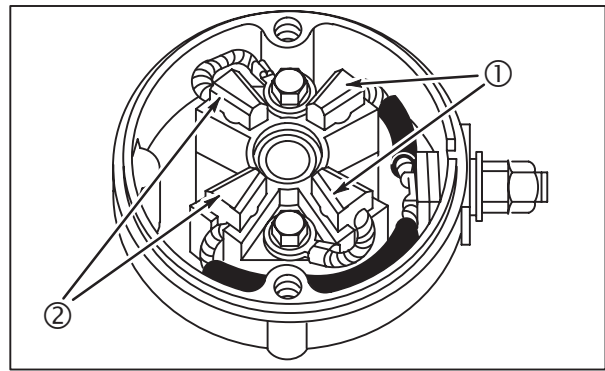


Fig. 20

## Assemble End Cap

**NOTE:** When all parts have been inspected, lightly lubricate bearings in both end caps with #20 oil.

### Radial Flat Coil Brush Spring

1. Assemble armature to brush end cap before installing brushes.
2. Install brush in holder.
3. Position coil spring over tab (1), Fig. 21.
4. While holding spring on tab, use a screwdriver and bend spring clockwise and position over end of brush.
5. Push spring down firmly over tab.
6. Repeat for remaining brushes.

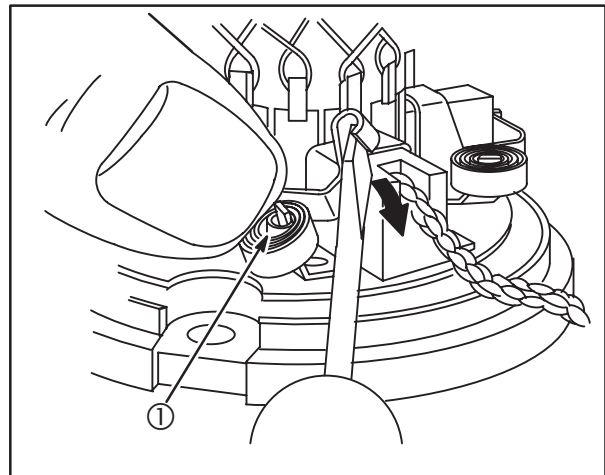


Fig. 21

### Radial Compression Brush Spring

End caps with radial compression type springs require 4 brush retainers (1) to hold brushes clear of armature commutator, Fig. 22.

Brush retainers can be made from Part #26634 control wire or similar material. The retainer is U shaped, with two legs  $1/2''$  (13 mm) high (2),  $3/4''$  (19 mm) long (3), Fig. 22, inset.

1. Install brush spring and brush into holder.
2. Compress brush and spring. Install retainer.
3. Repeat for remaining brushes.

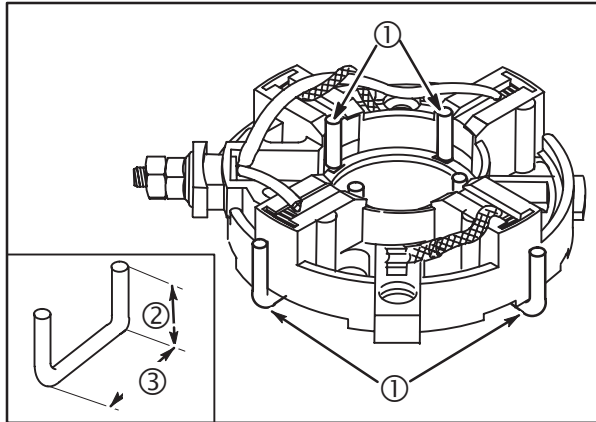


Fig. 22

### Axial Compression Brush Spring

Use a brush retainer to hold brushes in place while assembling the armature to the end cap.

Dimensions for the brush retainer in Fig. 23 are:

- (1) –  $7/8''$  (22 mm)
- (2) – 2" (51 mm)
- (3) – 1" (25 mm)
- (4) – 1" (25 mm)
- (5) –  $1/4''$  (6 mm) radius
- (6) –  $2-1/2''$  (64 mm)

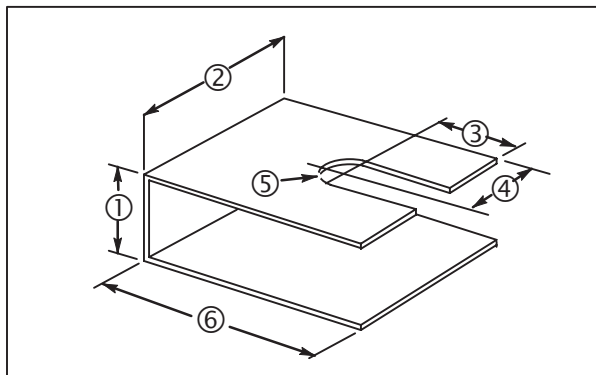


Fig. 23

1. Install positive (7) and negative (8) brushes with beveled edge UP in position shown, Fig. 24.

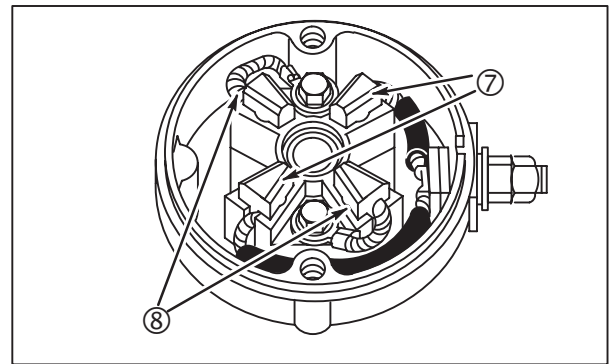


Fig. 24

2. Compress brushes and springs. Assemble brush retainer to end cap, Fig. 25.

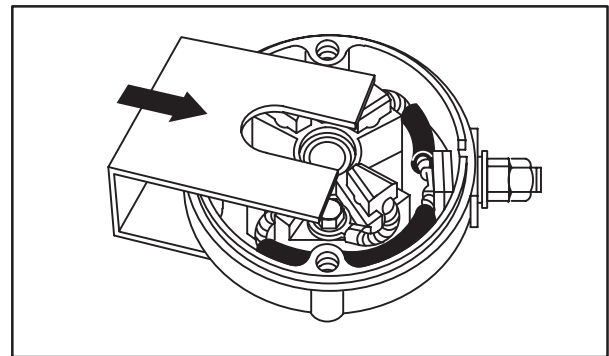


Fig. 25

### Assemble Armature

When all parts have been inspected, lightly lubricate bearings(1) in both end caps with #20 oil, Fig. 26.

1. Install spacer (2) to armature shaft (if equipped).
2. Assemble armature to brush end cap.
3. Remove brush retainer(s).

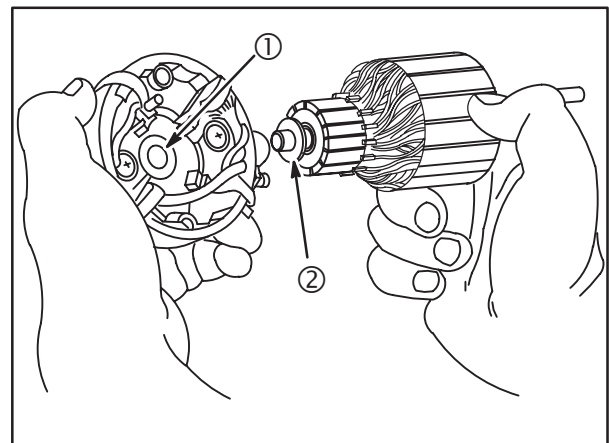


Fig. 26

### Assemble Housing

The starter housing (1) has a large notch (3) which indexes over the insulated terminal, Fig. 27.

1. Push down on armature and brush end cap.
2. Slide starter housing (1) over armature (2), aligning notch with insulated terminal.

**NOTE:** Use care to prevent damage to magnets in starter housing.

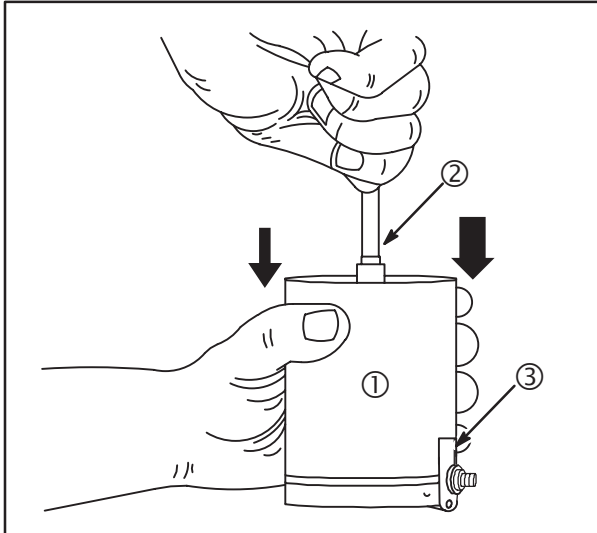


Fig. 27

7

### Install Drive End Cap

1. Assemble spacer washer (1) and spring washer (2, if equipped) to armature shaft, Fig. 28.
2. Assemble drive end cap (4) to armature shaft.
3. Align mark on end cap with mark on housing.
4. Install thru bolts (3). Torque to **50 in. lbs. (6 Nm)**.
5. Spin armature to check for binding. Correct any binding.
6. Install starter drive.

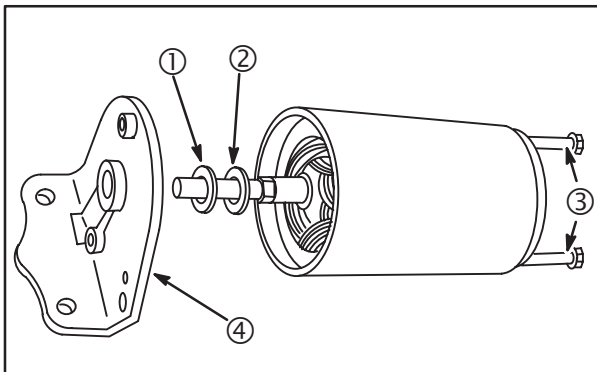


Fig. 28

## STARTER MOTOR SERVICE

*Models 540000, 610000*

### Remove Starter Solenoid

1. Remove nut and field coil wire from stud terminal.
2. Remove solenoid mounting nuts and solenoid
3. Lift solenoid to disengage drive lever from plunger, Fig. 29.

**NOTE:** Hold starter in vertical position with drive housing side DOWN when removing and installing solenoid.



Fig. 29

### Install Starter Solenoid

4. Engage flats on plunger (1) with fork in drive lever (2) and assemble solenoid to starter, Fig. 30. Torque nuts to **70 in. lbs. (8 Nm)**.
5. Install field coil wire and nut. Torque nut to **90 in. lbs. (10 Nm)**.

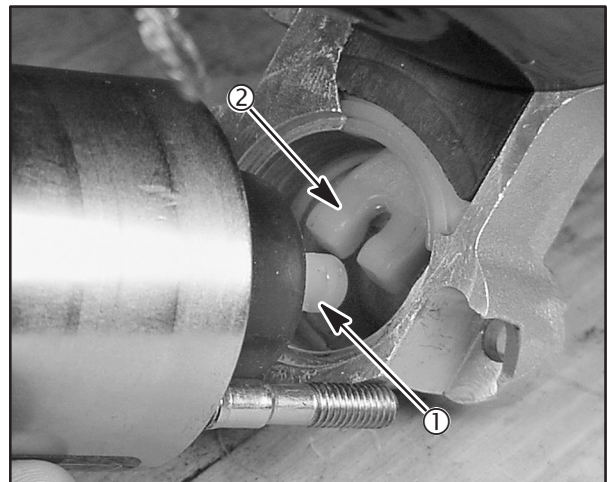


Fig. 30

## Pinion Gear

Pinion gear replacement requires complete starter motor disassembly. A thorough inspection of all components should be performed at that time.

### Disassemble Starter

For ease of disassembly and assembly, clamp drive end housing in a vise as shown, **Fig. 32**.

**NOTE:** Do not damage drive housing or mounting surface.

1. Remove solenoid.
2. Remove starter thru bolts.
3. Remove brush end cap, **Fig. 31**.

**NOTE:** To prevent losing brush springs, do not remove brush retainer (1) until starter housing has been removed from drive end cap, **Fig. 31**.



**Fig. 31**

4. Remove starter housing from drive end cap, **Fig. 32**.



**Fig. 32**

5. Remove armature and pinion gear with drive lever from drive end cap, **Fig. 33**.



**Fig. 33**

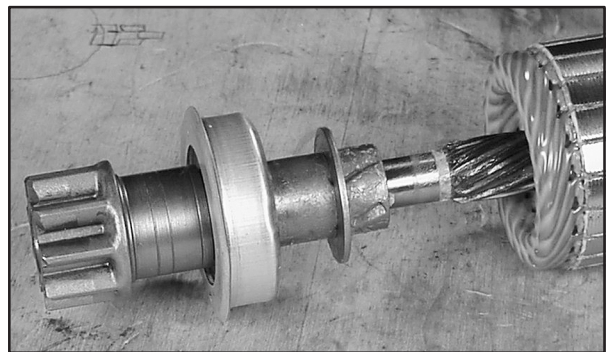
6. Remove spacer from armature shaft.
7. Use a 14 mm Carburetor Socket #19458 to drive retainer from C-ring, **Fig. 34**. Remove and discard C-ring and retainer.

**NOTE:** Always use a new C-ring and retainer.



**Fig. 34**

8. Remove pinion gear and clutch assembly, **Fig. 35**.



**Fig. 35**

Clean and inspect helix. If helix is damaged, replace starter. Inspect bearing journals on armature shaft for wear or damage. If bearing journals are worn or damaged, replace starter.

**NOTE:** Bearings in drive and brush end cap are not replaceable.

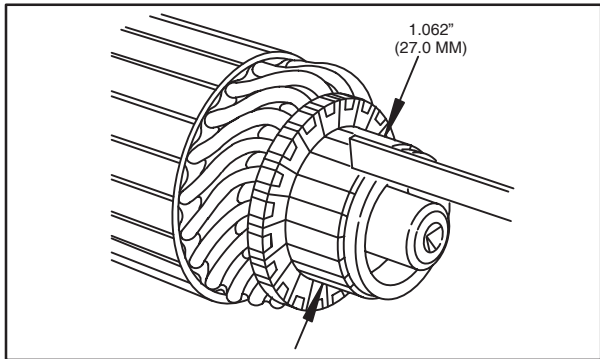
**Inspect Armature Commutator**

The armature commutator may be cleaned with fine sandpaper (#300 – 500 grit). DO NOT use emery cloth.

Commutator may be machined to **no less than 1.063” (27 mm)**, Fig. 36.

Slots between commutator bars should be cleaned with a hack saw blade after cleaning or machining.

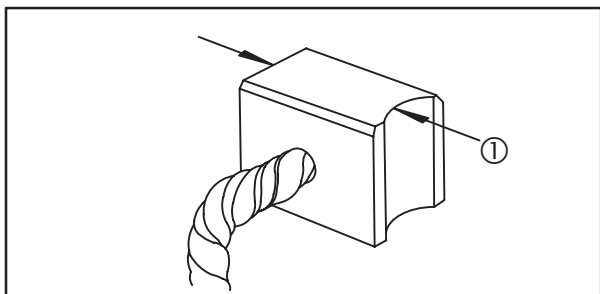
The armature should be checked for shorts with a growler.



**Fig. 36**

**Inspect Brushes**

Minimum brush dimension (1) is **1/4” (6 mm)**. If brushes are worn less than specification, replace the starter housing, Fig. 37.

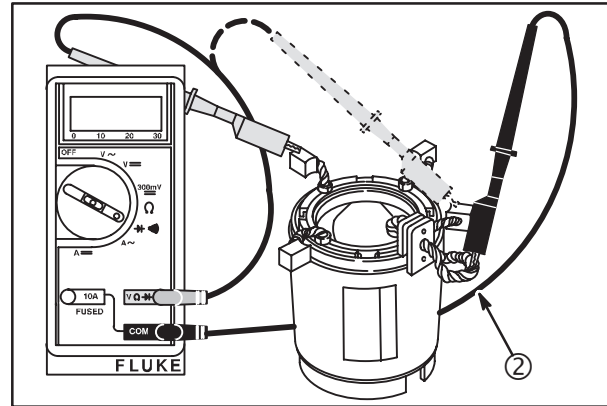


**Fig. 37**

Use digital multimeter and check for continuity between field coil wire and brushes shown, Fig. 38.

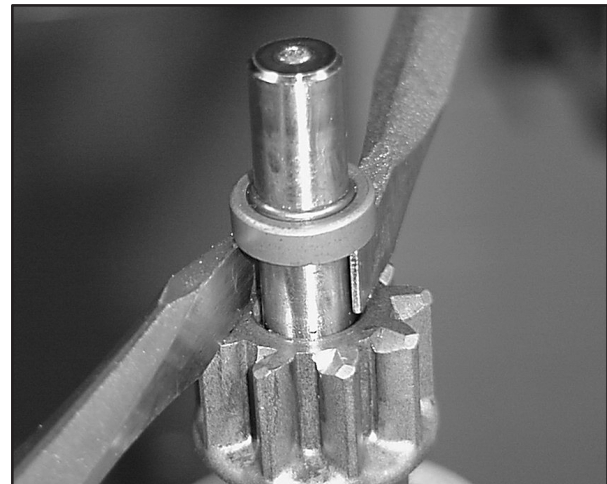
The following test will be made with the meter in the **→+ (Diode Test) Position**.

1. Attach either meter test lead to field coil wire (2).
2. Contact first one, then other brush with other test lead as shown.
  - a. Meter should indicate continuity (continuous tone).
  - b. Replace starter housing if meter does not indicate continuity.



**Fig. 38**

3. Attach either test lead to starter housing, Fig. 40.



**Fig. 39**

4. Contact first one, then the other brush with other test lead as shown.
  - a. Meter should indicate continuity (continuous tone).
  - b. Replace starter housing if meter does not indicate continuity.

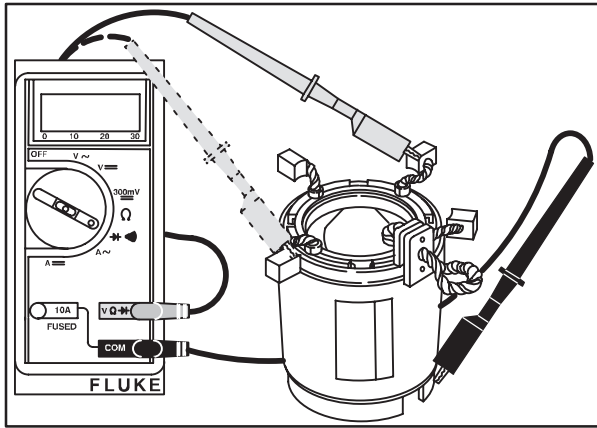


Fig. 40

**Assemble Pinion Gear**

1. Lubricate helix with a light coat of grease. Assemble pinion gear and clutch.
2. Assemble new retainer to shaft.
3. Install new C-ring.
4. Pry up on retainer until C-ring snaps into groove in retainer, **Fig. 39**.
5. Assemble spacer to armature shaft, **Fig. 41**.

**NOTE:** Lip (1) on spacer must face bearing in drive end cap.

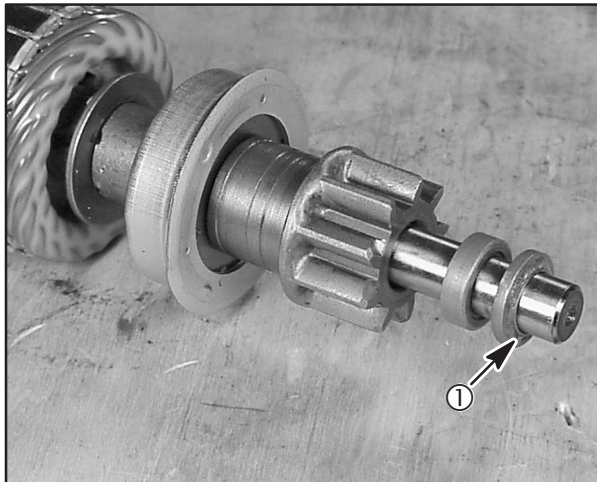


Fig. 41

**Assemble Starter**

1. Assemble drive lever (2) to pinion (1). Install armature and drive lever into drive housing (3), **Fig. 42**.

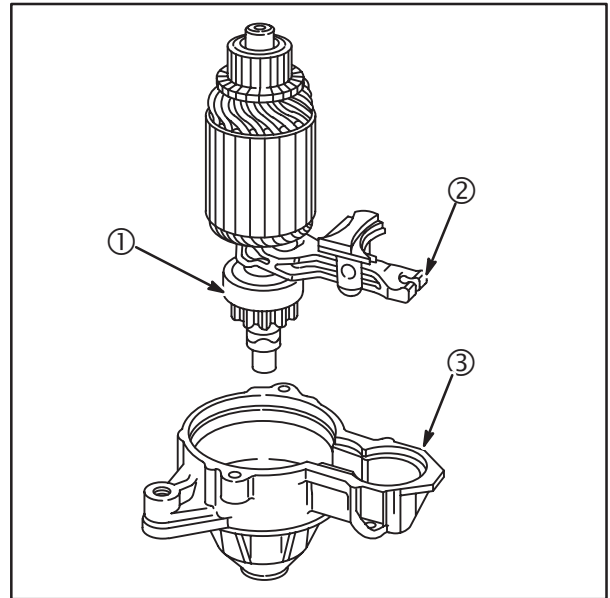


Fig. 42

2. Assemble starter housing to drive housing, engaging notch in housing with tab on drive lever support, **Fig. 43**.

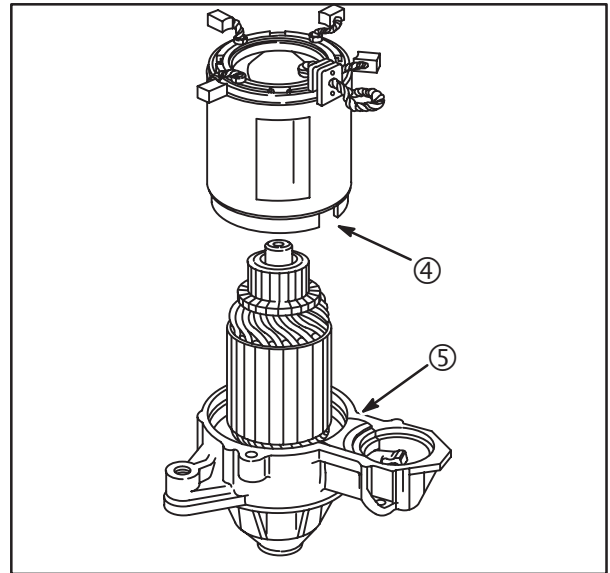
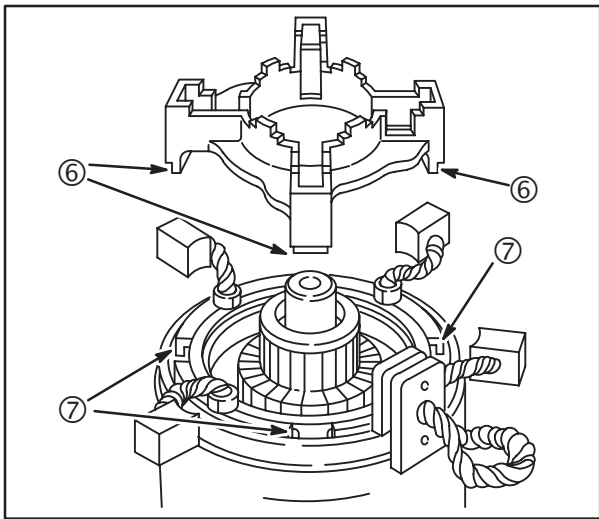


Fig. 43

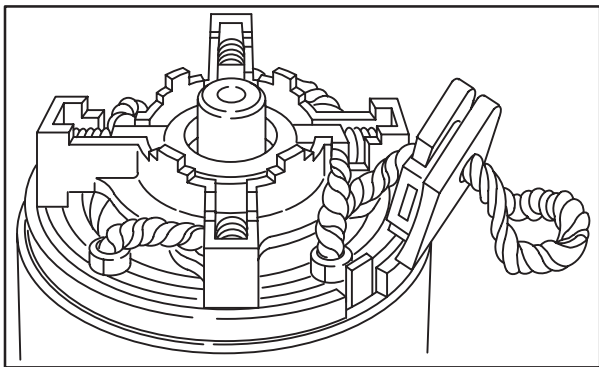
3. Install brush holder, inserting tabs on brush holder (6) into starter housing slots (7), **Fig. 44**.





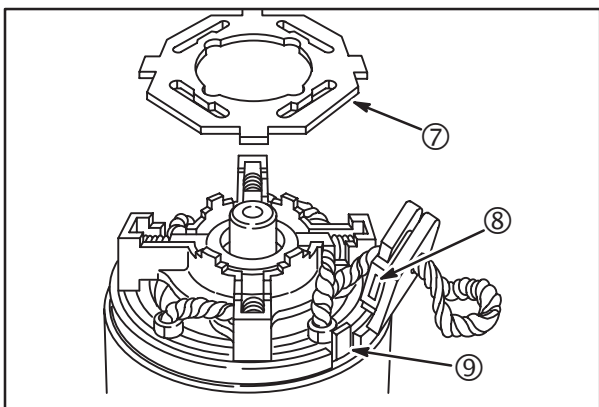
**Fig. 44**

4. Insert brushes into brush holder, **Fig. 45**.
5. Compress springs with needle nose pliers and insert spring behind brushes.



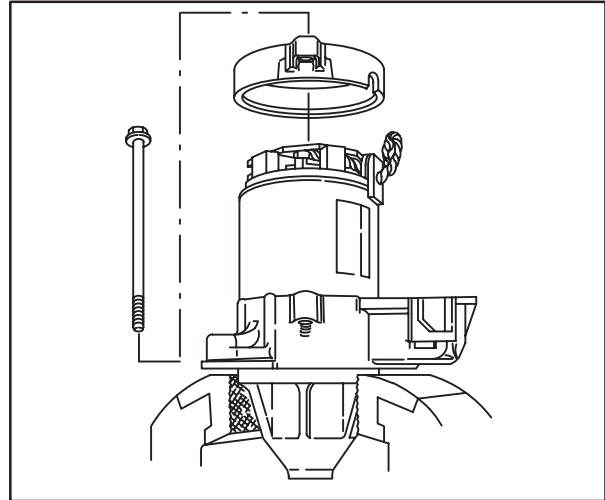
**Fig. 45**

6. Install brush retainer plate (7), **Fig. 46**.
7. Assemble rubber seal to starter housing. Be sure notch in rubber seal (8) is inserted over tab on housing (9).



**Fig. 46**

8. Install end cap, **Fig. 47**. Torque thru bolts to **70 in. lbs. (8 Nm)**.



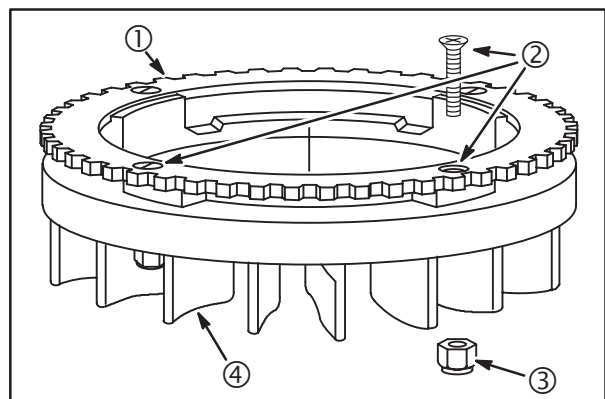
**Fig. 47**

9. Install solenoid, see "Starter Solenoid."

## RING GEAR SERVICE

**NOTE: Ring gear is not replaceable on models 540000, 610000.**

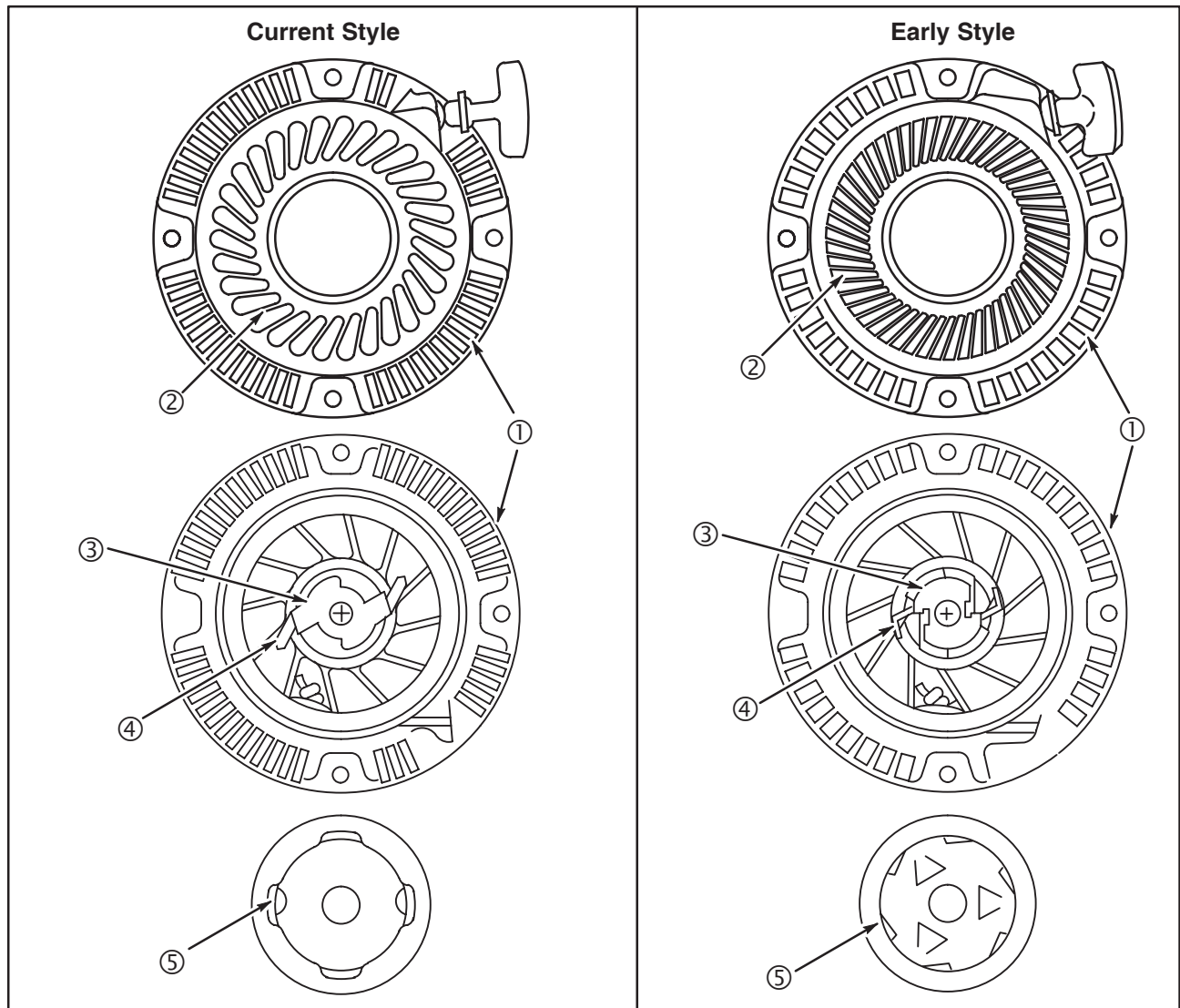
1. Mark center of rivets holding the ring gear (1) to flywheel (4), **Fig. 48**, with a center punch.
2. Drill out rivets using a #13 drill bit.
3. Remove ring gear and clean mounting surface.
4. Attach new gear to flywheel using four screws (2) and lock nuts (3) provided with gear. Tighten nuts and screws securely.



**Fig. 48**

## REWIND STARTER IDENTIFICATION

Two rewind starters are used on V-Twin engines. The rewind starter components (including the starter and cup) are NOT INTERCHANGEABLE between starters. **Figure 49** shows how to identify the rewind starters.



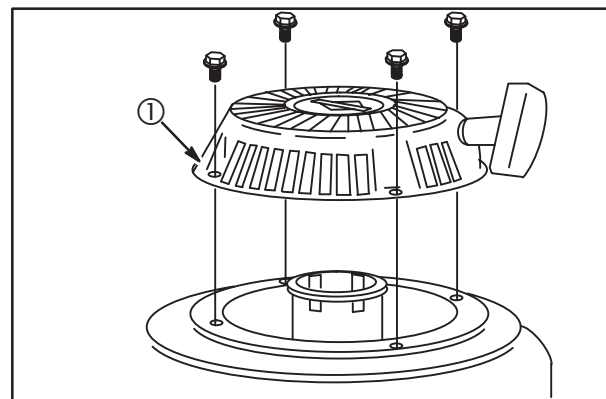
**Fig. 49**

1. Rewind Starter.
2. Air Inlet Slots – larger on current starters.
3. Retainer – nylon on current starters, metal on early starters.
4. Starter Dogs – nylon on current starters, metal on early starters.
5. Starter Cup – large notches on current starters, small notches on early starters.

## REWIND STARTER SERVICE

### Remove Rewind Starter

1. Remove four screws and rewind starter (1), **Fig. 50**.

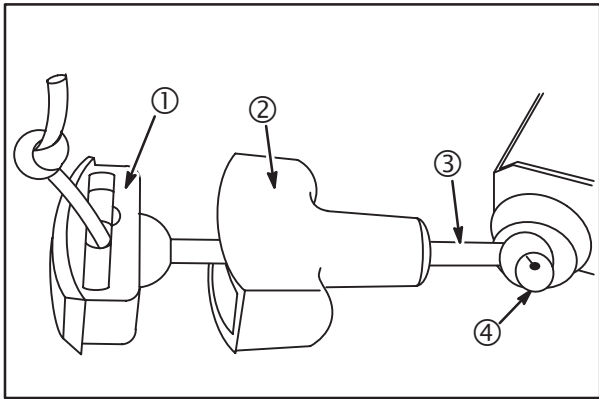


**Fig. 50**

## Replace Rope

### Remove Rope

1. Pull rope out partially. Tie a temporary knot (4), **Fig. 51**.
2. Remove insert (1) from rope handle (2). Pull knot out of rope insert.
3. Untie knot. Remove insert and handle from rope.
4. Pull rope (3) out as far as it will go.
5. While holding rewind pulley, grasp knot with a pair of needle nose pliers and pull rope out of pulley.
6. Slowly release spring tension on pulley until pulley stops turning.

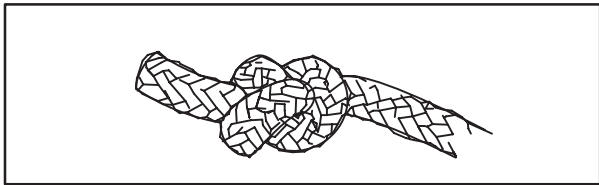


**Fig. 51**

### Install Rope

**NOTE:** Cut replacement rope to **80" (203 cm)**.

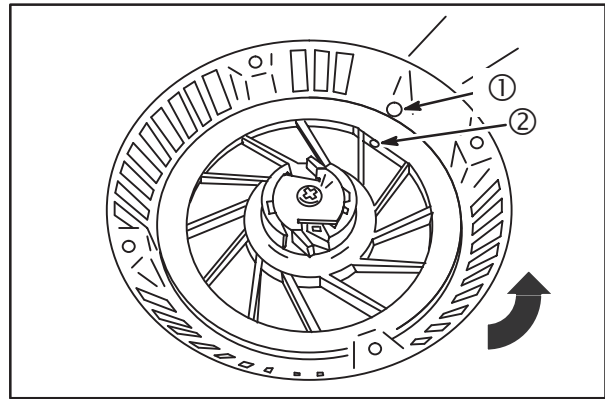
1. After cutting rope, heat end with an open flame. Wipe with a rag to prevent unraveling.
2. Tie a figure eight knot at one end of rope, **Fig. 52**.



**Fig. 52**

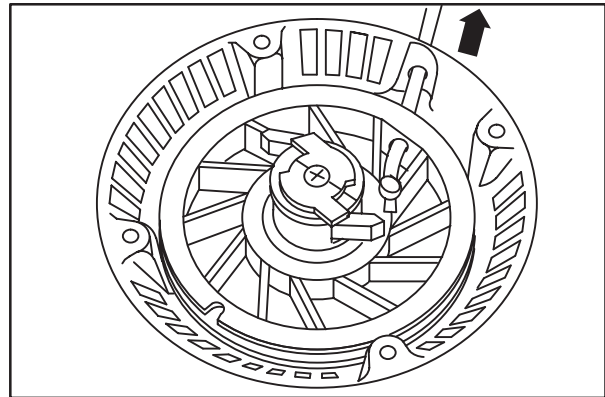
3. Rotate pulley **COUNTERCLOCKWISE** (arrow) six complete turns, **Fig. 53**.

4. Rotate pulley **CLOCKWISE** just until rope hole in pulley (2) is in line with starter housing eyelet (1).
5. Hold pulley in this position.



**Fig. 53**

6. Insert rope through pulley and eyelet in housing, **Fig. 54**.
7. Pull rope until knot is seated.
8. While holding pulley, tie a temporary knot part way out on rope.
9. Let pulley and spring slowly rewind pulling rope into temporary knot.



**Fig. 54**

10. Insert rope (4) through starter rope handle (3) and handle insert (2), **Fig. 55**.
11. Tie knot on end of rope.
12. Pull knot (1) into rope insert and pull insert into rope handle.
13. Untie temporary knot (5) and slowly let rope rewind into starter.
14. Operate starter to check for smooth operation.

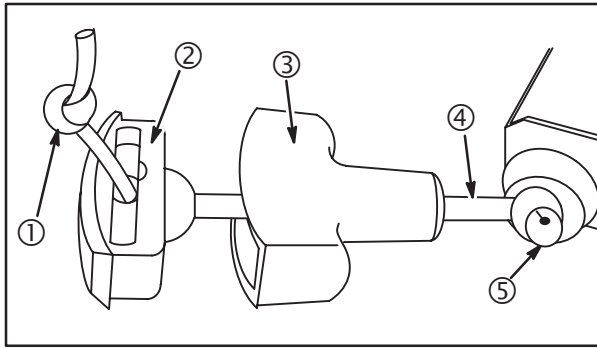



Fig. 55

## Replace Pulley and Spring

### Current Style

	<p style="text-align: center;"><b>CAUTION</b></p> <p style="text-align: center;"><b>PREVENT EYE INJURY!</b></p>
<ul style="list-style-type: none"> <li>• Wear eye protection when working on starter pulley and spring.</li> <li>• Pulley and spring is serviced as an assembly. <b>DO NOT</b> remove spring from pulley.</li> </ul>	

1. Remove rope.
2. Remove shoulder screw (1) and retainer (2), **Fig. 56**.
3. Lift out dogs (3) and dog springs (4).

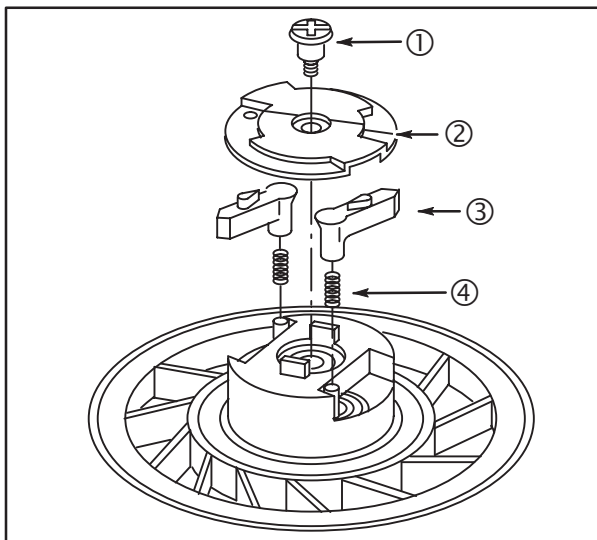


Fig. 56

4. Rotate pulley **CLOCKWISE** until pulley disengages spring.

5. Carefully lift out pulley with spring, **Fig. 57**.

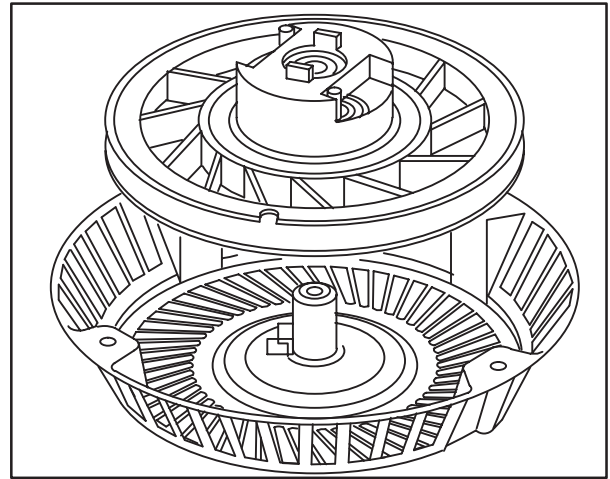


Fig. 57

### Inspect Starter Housing and Pulley

Inspect pulley for wear, cracks, rough edges or burrs in pulley groove (2) and wear on center hole (1), **Fig. 58**. Replace pulley if damaged or worn.

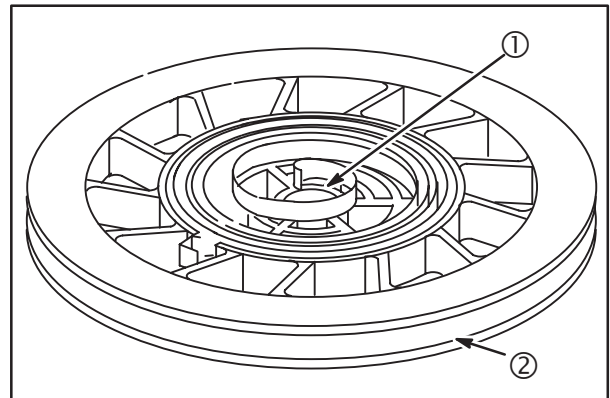


Fig. 58

Inspect starter housing for wear or sharp edges at rope eyelet (4), center pivot post (5), and inner spring anchor (3) tab, **Fig. 59**. Replace housing if worn or damaged.

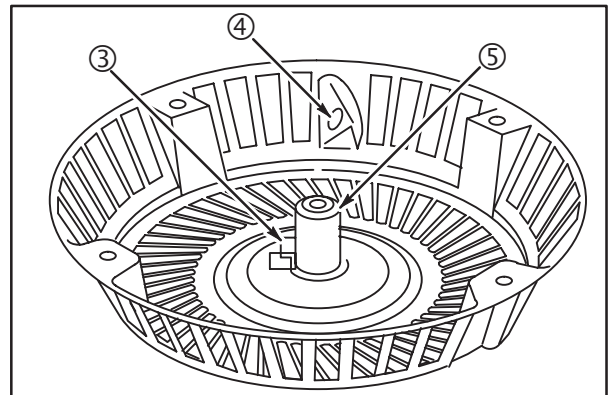
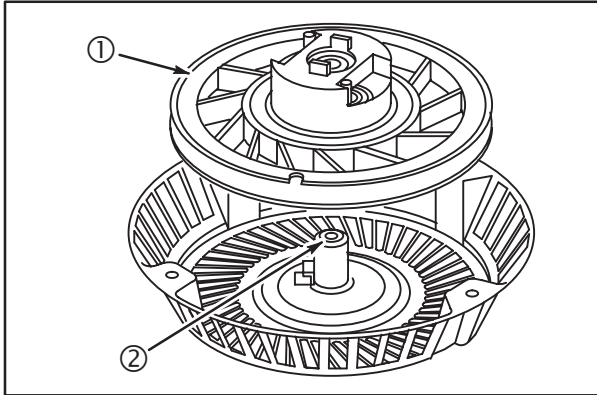


Fig. 59

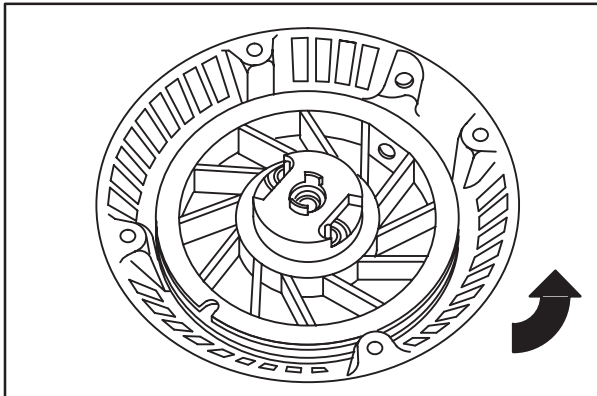
### Assemble Pulley To Housing

1. Lay starter housing on work bench.
2. Assemble starter pulley (1) and spring assembly to center pivot post (2) in housing, **Fig. 60**.



**Fig. 60**

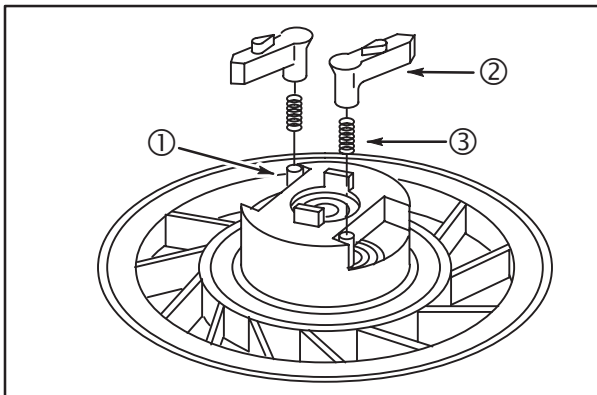
3. Rotate pulley **COUNTERCLOCKWISE** until slight resistance is felt, indicating that spring is engaged in spring tab in housing, **Fig. 61**.



**Fig. 61**

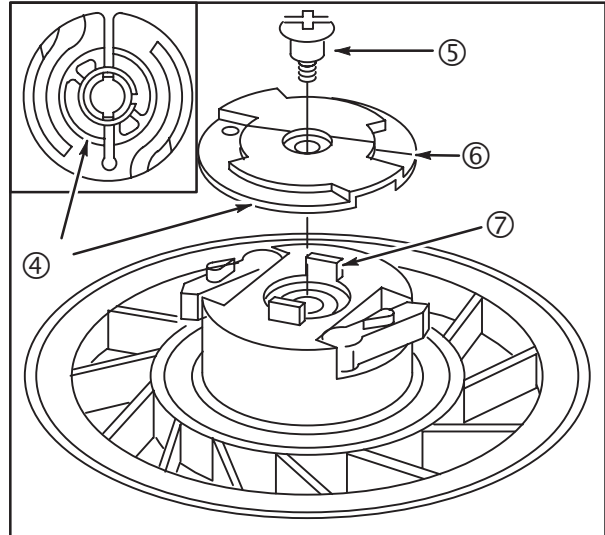
### Install Dogs, Dog Springs, Retainer Assembly

1. Position springs (3) over posts in pulley (1). Install dogs (2), **Fig. 62**.



**Fig. 62**

2. Install retainer making sure that slots (4) in retainer (6) engage tabs (7) on pulley, **Fig. 63**.
3. Hold retainer down, compressing dog springs and install retainer screw (5). Torque screw to **70 in. lbs. (8 Nm)**.
4. Install rope.



**Fig. 63**

### Replace Pulley and Spring

#### Early Style

	<p><b>CAUTION</b></p> <p><b>PREVENT EYE INJURY!</b></p>
<ul style="list-style-type: none"> <li>• Wear eye protection when removing spring and cup assembly.</li> <li>• Spring and cup are serviced as an assembly. <b>DO NOT</b> attempt to remove spring from cup.</li> </ul>	

1. Remove rope.
2. Remove shoulder screw (1), small washer (2), retainer (3), brake spring (4) and large washer (5), **Fig. 64**.

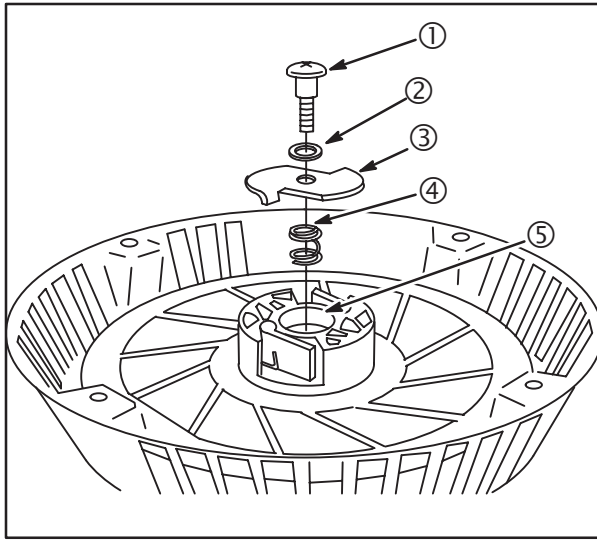


Fig. 64

3. Lift out dogs (6) and dog springs (7).
4. Rotate pulley (8) until it disengages spring.
5. Carefully lift out pulley, Fig. 65.

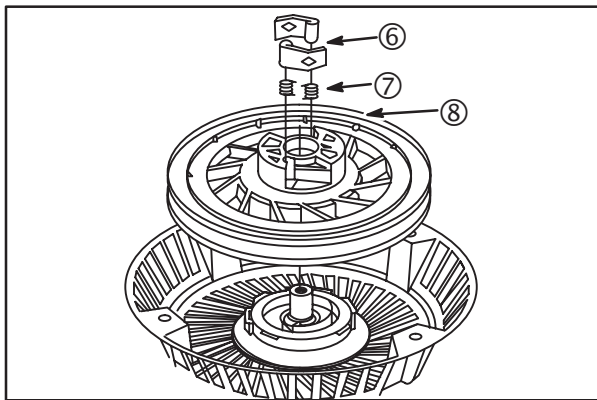


Fig. 65

The starter spring and cup will normally remain as an assembly in starter housing.

6. Remove spring and cup assembly (9) from starter housing, Fig. 66.

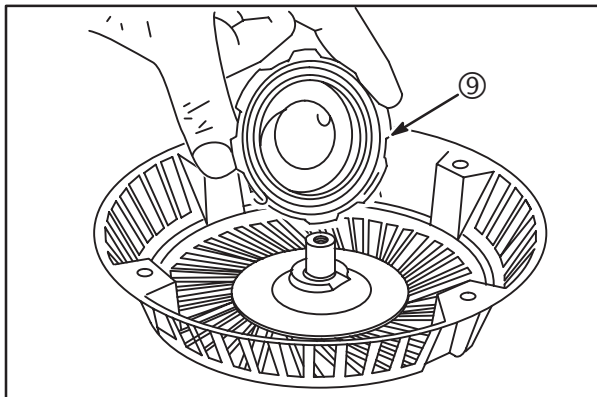


Fig. 66

### Inspect Spring, Starter Housing and Pulley

Inspect pulley for cracks, rough edges (1) or burrs in pulley groove, wear on spring cup lugs (2), and wear on center hole (3), Fig. 67. Replace pulley if damaged or worn.

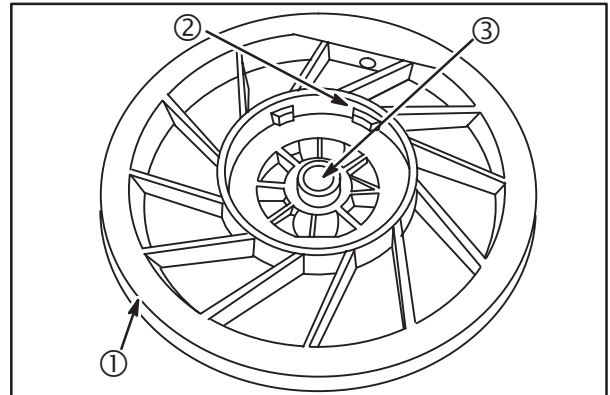


Fig. 67

Inspect starter housing for wear and sharp edges at rope eyelet (5), center pivot post (4), and at inner spring anchor (6), Fig. 68. Replace if worn or damaged.

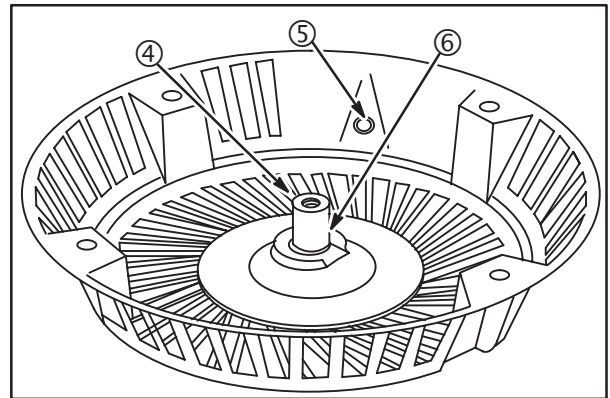


Fig. 68

### Install Spring, Cup Assembly and Pulley In Starter Housing

1. Place spring and cup assembly in pulley with outer end of spring tab (2) between two wide lugs in pulley (1) and spring cup projections (3) next to the two wide lugs, Fig. 69.

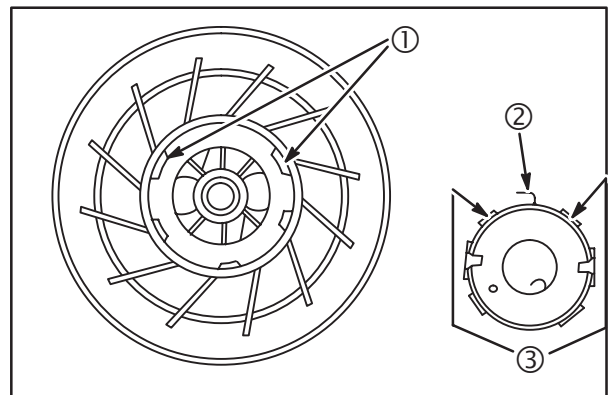
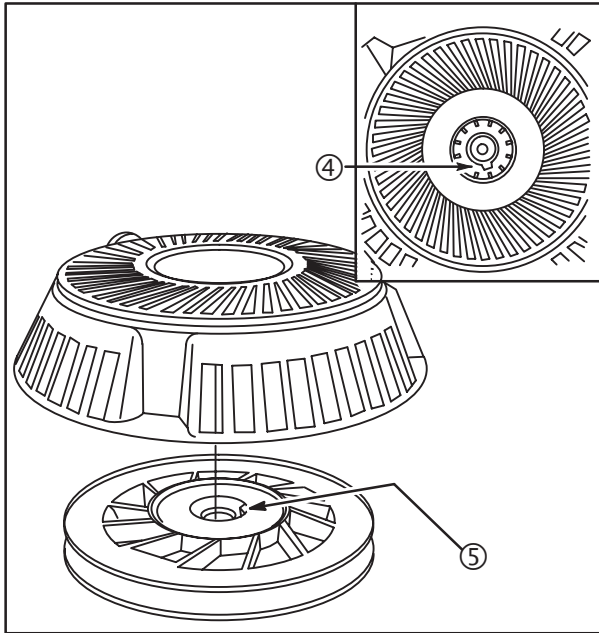


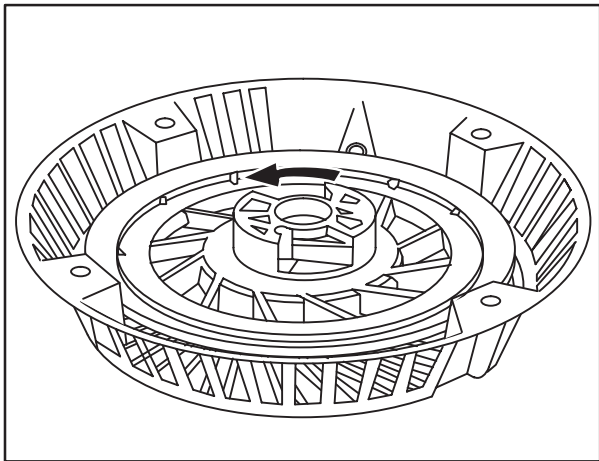
Fig. 69

- Note location of spring tab (5) and location of spring anchor (4) on center post of starter housing.
- Lower starter housing onto pulley and spring assembly, **Fig. 70**.



**Fig. 70**

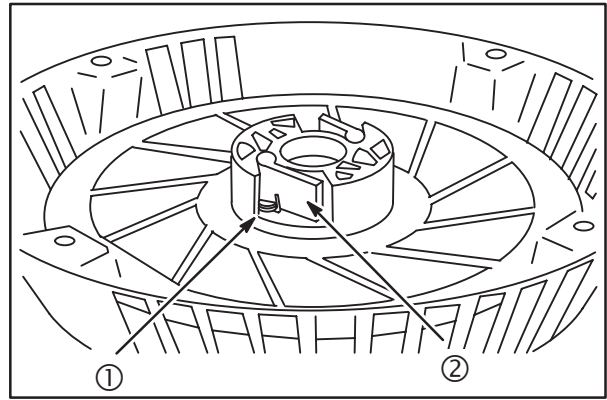
- Invert assembly, rotate pulley counterclockwise until inner spring tab engages spring anchor, **Fig. 71**.



**Fig. 71**

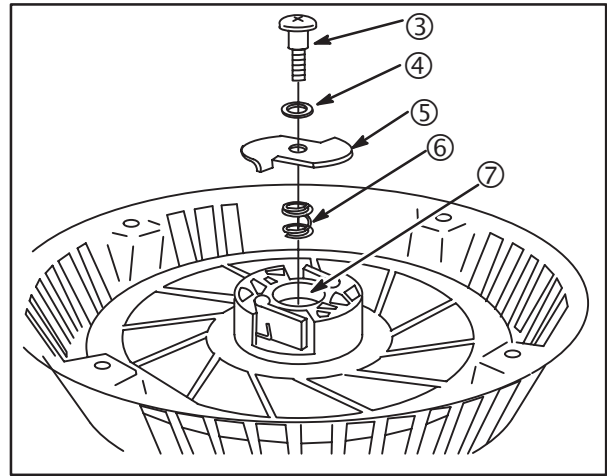
#### **Install Dogs, Dog Springs, Retainer Assembly**

- Install dogs (2) and dog springs (1) in pulley, **Fig. 72**.



**Fig. 72**

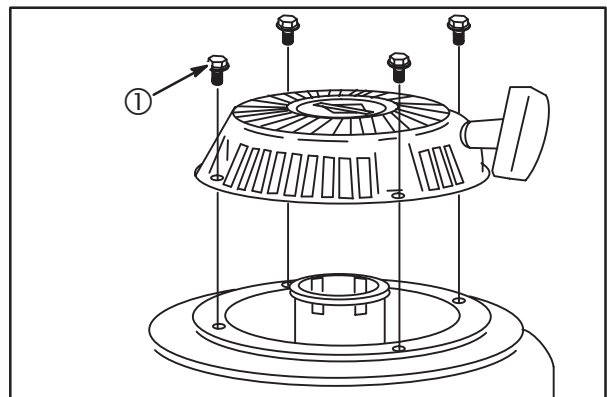
- Place large washer (7), brake spring (6) and retainer (5) on pulley, **Fig. 73**.
- Place small washer (4) on shoulder screw (3). Install screw and washer in center pivot post.
- Position tabs of retainer inside dogs. Torque screw to **70 in. lbs. (8 Nm)**.
- Install rope.



**Fig. 73**

#### **Install Rewind Starter**

- Install rewind starter on blower housing and install screws (1) finger tight, **Fig. 74**.
- Pull rope to engage dogs in starter cup.
- While holding rope, tighten screws to **60 in. lbs. (7 Nm)**.



**Fig. 74**

# Section 8

## Lubrication Systems

---

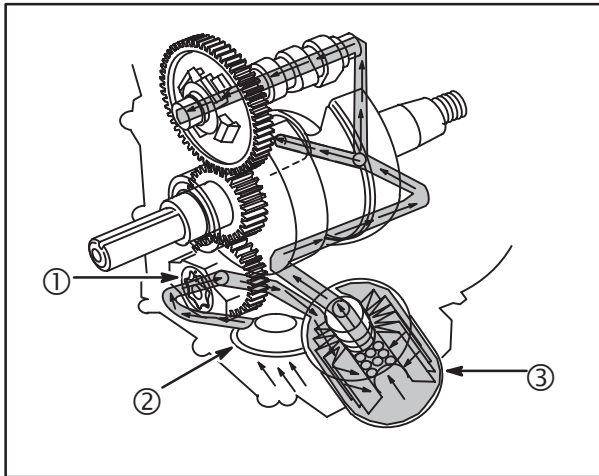
	Page
CRANKCASE BREATHER IDENTIFICATION .....	144
CRANKCASE BREATHER SERVICE .....	145
Models 290000, 300000, 350000, 3510000 .....	145
Model 380000 .....	146
Models 540000, 610000 .....	147
GENERAL INFORMATION .....	144
OIL FILL TUBE AND DIPSTICK .....	147
OIL PUMP .....	147



## GENERAL INFORMATION

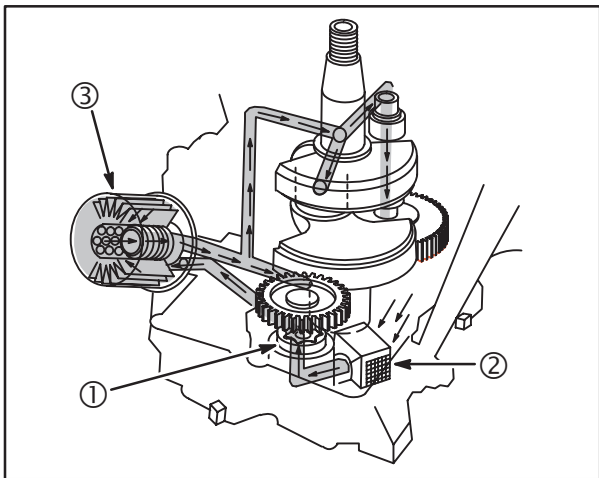
Briggs & Stratton Vanguard™ OHV V-Twins use a full pressure lubrication system with an oil filter. The gear driven oil pump (1) draws oil from a screened oil pickup (2) in the sump and pumps the oil through the oil filter (3). The lubrication systems shown are:

Horizontal Crankshaft Engines, **Fig. 1.**



**Fig. 1**

Vertical Crankshaft Engines, **Fig. 2.**



**Fig. 2**

Filtered oil flows through oil galleries in the sump and is distributed to the main bearings, connecting rod bearings and camshaft bearings. Engine oil pressure will vary with oil viscosity, ambient air temperature differences, operating temperatures and engine load. Follow the oil recommendations in Section 1.

A pressure relief valve limits the maximum oil pressure in the system.

An optional oil pressure switch is available. The switch may be used to activate a warning device if oil pressure drops below approximately **5 psi (0.3 Bar)**. The warning device and wiring is supplied by the OEM.

## Crankcase Breather Identification

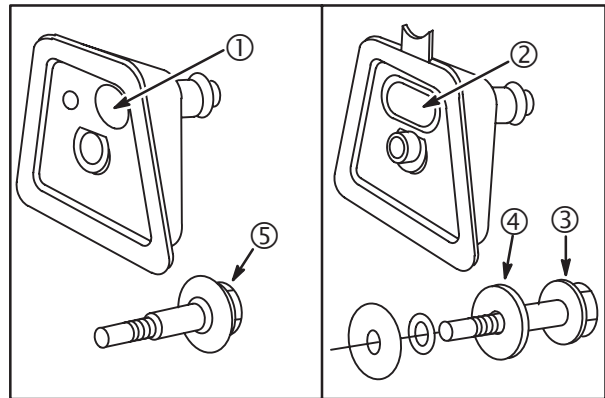
Vanguard™ engines utilize a breather valve to control and maintain a vacuum in the crankcase. The breather vents crankcase vapors through the air cleaner.

### **Models 290000 – 351000**

The breather is located on the valley between the cylinders.

Two styles of breathers are used, **Fig. 3.** The current style breather (left) uses a reed valve (1) to maintain crankcase vacuum. Early style breathers (right) contain a fiber disc type valve (2).

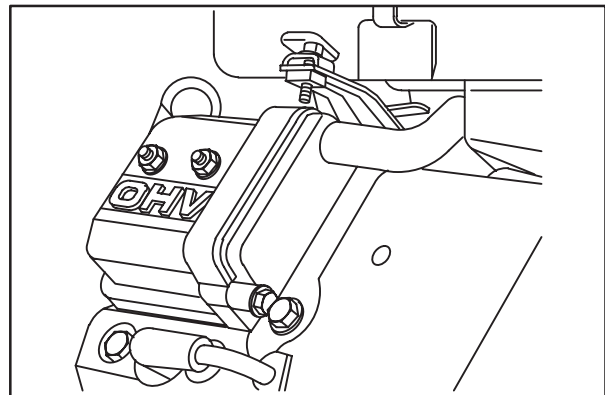
**NOTE:** The early breather mounting screw (3) used a washer (4) and O-rings that are not used on the current screw (5). The screws and breathers are NOT interchangeable.



**Fig. 3**

### **Models 380000, 540000, 610000**

The breather is located in the valve cover of the number 2 cylinder, **Fig. 4.** The breather uses a reed valve to maintain crankcase vacuum. The reed valve is replaceable.



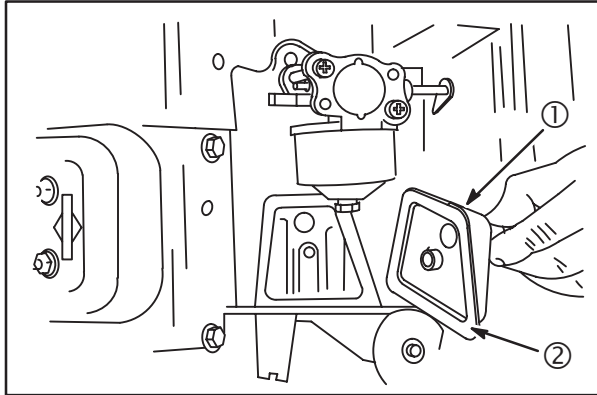
**Fig. 4**

## CRANKCASE BREATHER SERVICE

Models 290000 – 351000

Remove the air cleaner assembly.

Remove breather assembly (1). Discard gasket (2), **Fig. 5**.

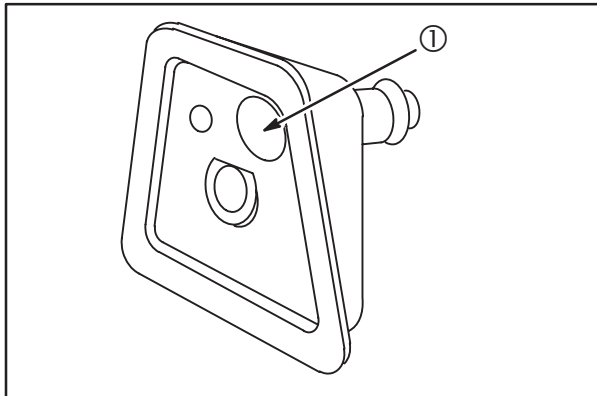


**Fig. 5**

### Checking Reed Valve Breather

The reed valve is spring loaded and must make a complete seal around the vent hole (1) in breather body, **Fig. 6**. Check to see that reed valve is not deformed.

**CAUTION:** Do not use force on the reed valve.

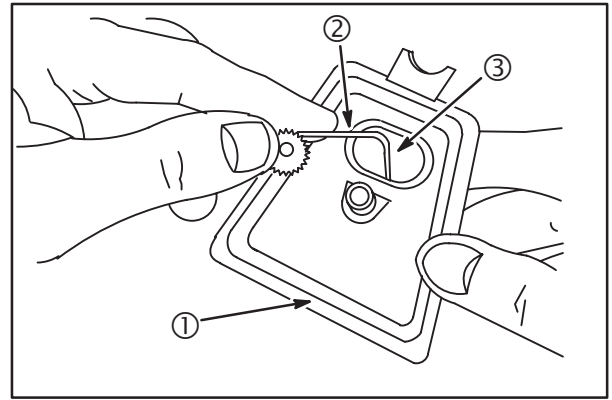


**Fig. 6**

### Checking Fiber Disc Breather

If the fiber disc valve (3) is stuck or binding, the breather assembly (1) must be replaced. A **0.045" (1.14 mm)** wire gauge (2) should not enter the space between the fiber disc valve and body, **Fig. 7**.

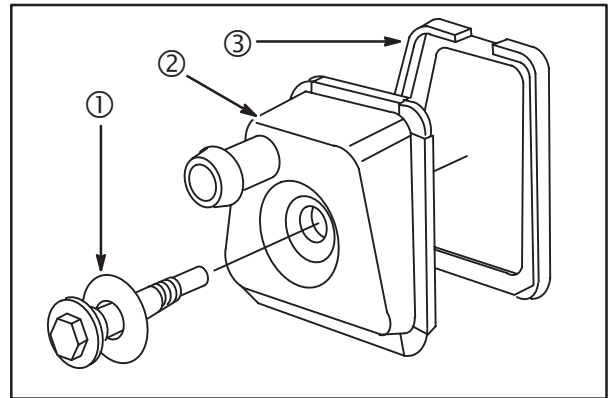
**CAUTION:** Do not use force on the fiber disc.



**Fig. 7**

### Install Reed Valve Breather

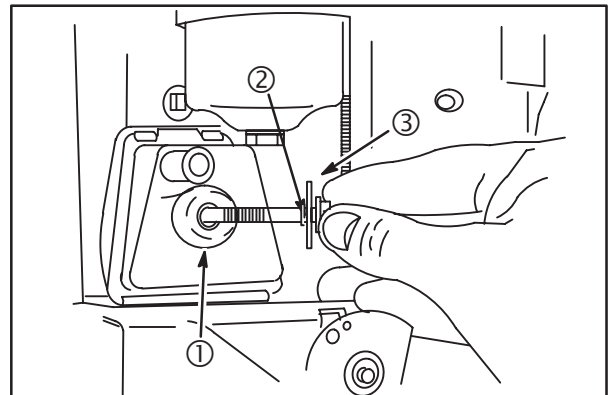
1. Place breather (2) on gasket (3), **Fig. 8**.
2. Assemble large O-ring (1) onto mounting screw.
3. Install screw. Torque to **30 in. lbs. (3 Nm)**.



**Fig. 8**

### Install Fiber Disc Breather

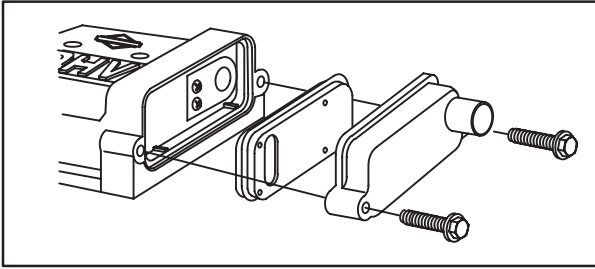
1. Place breather on gasket.
2. Place large O-ring (1) on breather, **Fig. 9**.
3. Assemble washer (3) and small O-ring (2) to screw.
4. Install screw. Torque to **30 in. lbs. (3 Nm)**.



**Fig. 9**

## Model 380000

Remove two screws. Separate breather assembly from valve cover, **Fig. 10**.

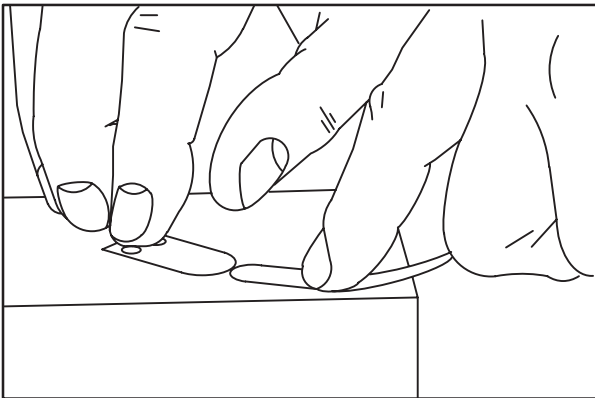


**Fig. 10**

### Checking Breather

1. Remove two screws, reed stop and reed valve.
2. Place reed valve on flat surface.
3. Check reed valve for distortion with feeler gauge, **Fig. 11**.

Replace reed valve if the maximum distortion exceeds **0.010" (0.25 mm)**.

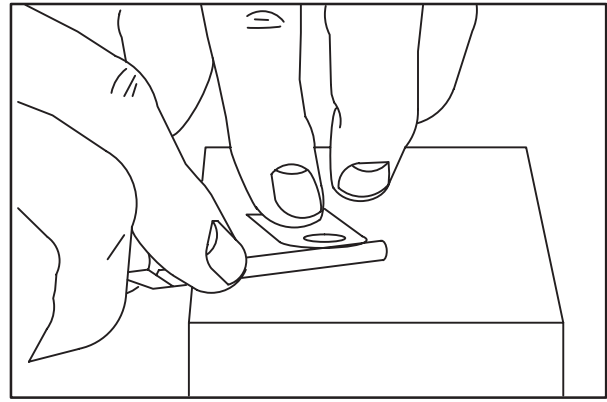


**Fig. 11**

Check reed stop height in the following manner.

4. While holding mounting surface of reed stop on flat surface, use the following drills to check reed stop height, **Fig. 12**.
5. Use **#29** drill as GO gauge.
6. Use **#24** drill as NO-GO gauge.

Replace reed stop if not to specification.



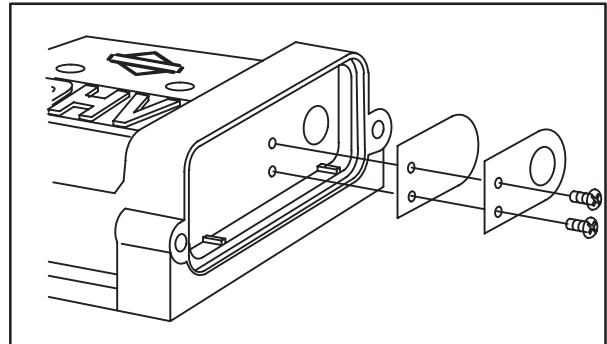
**Fig. 12**

### Install Breather

1. Assemble reed valve and reed stop to breather body, **Fig. 13**. Tighten screws securely.

**NOTE:** Holes in reed and reed stop are offset. Assemble so that holes are aligned.

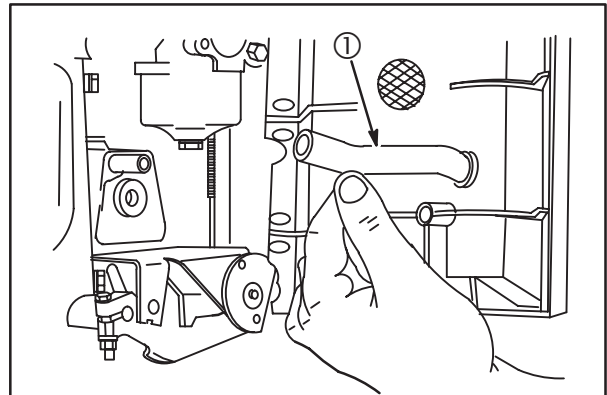
2. Assemble baffle and cover to valve cover with new gasket.
3. Torque screws to **30 in. lbs. (3 Nm)**.



**Fig. 13**

### Inspect Breather Tube

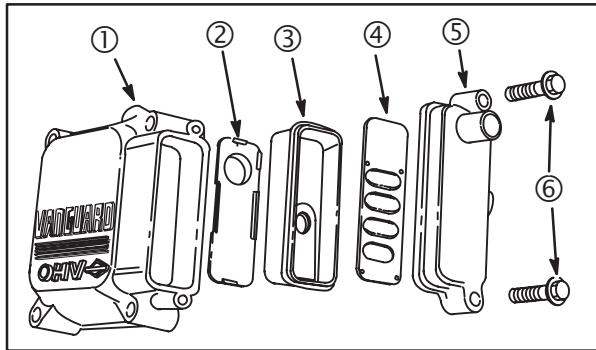
Check breather tube(s) (1) for cracks, holes or hardening, **Fig. 14**. Replace if damaged.



**Fig. 14**

## Models 540000, 610000

1. Remove two screws (6) and breather cover (5), **Fig. 15**.
2. Lift off the outer baffle (4).
3. Remove the reed valve assembly (3) and O-ring.
4. Remove the inner baffle (2) from the valve cover (1).



**Fig. 15**

### Check Breather

Check for loose rivets and for damage to the reed valve, reed stop and housing. If any of the components are worn or damaged, or if the reed valve does not lay flat over the opening, replace the assembly.

### Install Breather

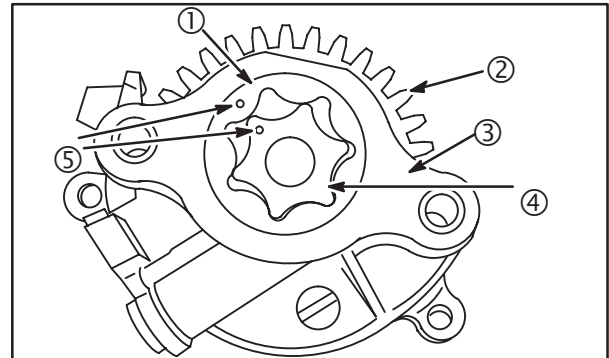
**NOTE:** For correct alignment, the breather components have one corner that is a sharper radius than the others. **DO NOT** force components into an incorrect position.

1. Install the inner baffle with raised edges facing **OUT**.
2. Install the reed valve assembly into the valve cover, reed valve facing out.
3. Install the O-ring over the reed valve assembly. Use fingertips to seat the O-ring into the valve cover.
4. Position the outer baffle into the breather cover with the 3 bosses facing **OUT**.
5. Install the breather cover and baffle onto the valve cover.
6. Reinstall screws.

## Oil Pump

### Inspect

Inspect pump drive gear (2) for worn or chipped teeth. Inspect inner pump rotor (4), outer pump rotor (1), housing (3) and crankcase cover or sump for scoring or wear. Replace as required.



**Fig. 16**

### Assemble Oil Pump

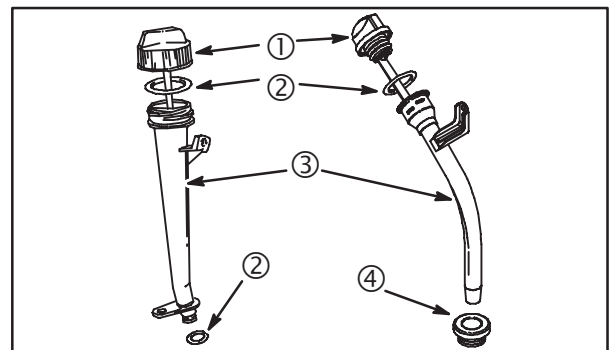
Lubricate rotors with oil. Install in pump with dimples aligned (5), **Fig. 16**.

## Oil Fill Tube and Dipstick

### All Models – Except 540000, 610000

The oil fill tube (3) and the dipstick (1) are equipped with O-rings (2) and/or a grommet (4) for proper sealing, **Fig. 17**.

**NOTE:** A leak at the seal between the tube and sump, or at the seal at the upper end of the dipstick, can result in a loss of crankcase vacuum and a discharge of oil or smoke through the muffler.

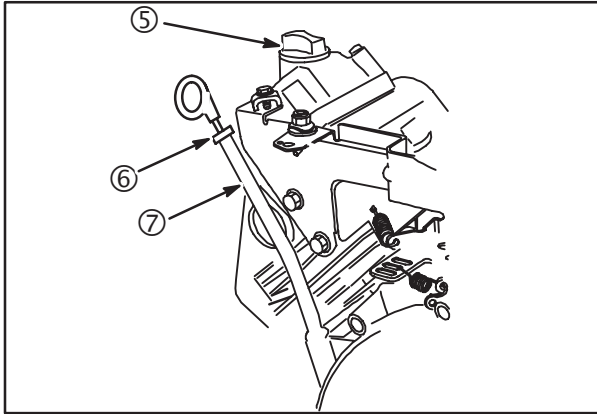


**Fig. 17**

**Models 540000, 610000**

For proper sealing on these models, the oil fill cap (5) has an O-ring, the dipstick has a grommet (6), **Fig. 18**.

**NOTE:** The oil dipstick tube (7) is not removeable/ serviceable on these models. If damaged replace the crankcase cover.



**Fig. 18**

# Section 9

## Cylinders and Crankcase Covers/Sumps

---

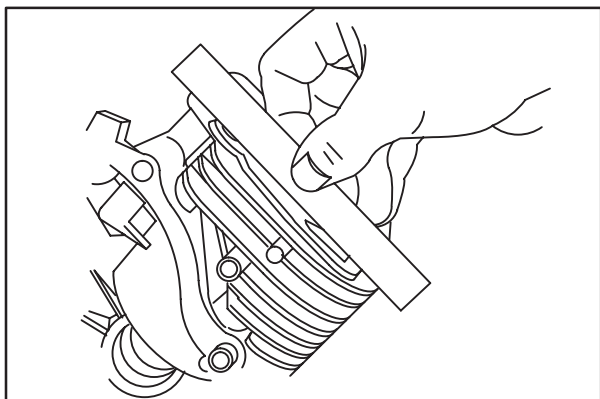
	Page
<b>CYLINDERS</b> .....	150
Inspect and Measure .....	150
Resizing Cylinder .....	150
Finishing .....	151
Cleaning .....	151
<b>ENGINE BEARINGS</b> .....	152
Mag Bearing (before 970501xx) .....	152
Mag Bearing (after 970430xx) .....	152
PTO Ball Bearing .....	153
PTO Plain Bearing .....	154
Oil Seal .....	154
Camshaft Bearings .....	154

## CYLINDERS

### Inspect and Measure

1. Check cylinder for cracks, stripped threads or broken fins. Check cylinder bores for damage or scoring.
2. Check cylinder head mounting surface for distortion with a straight edge, **Fig. 1**.

Replace the cylinder if the mounting surfaces are distorted more than **0.004" (0.1 mm)**.

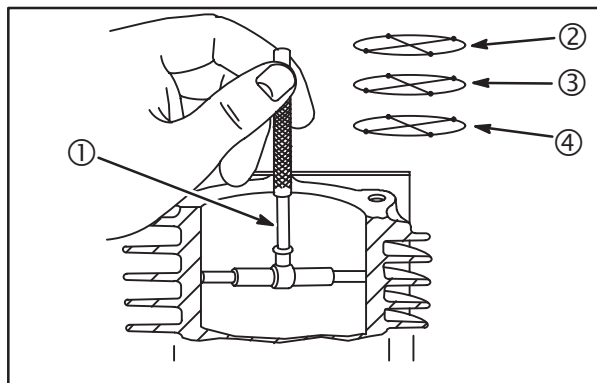


**Fig. 1**

3. Use Telescoping Gauge #19404 (1) and Dial Caliper #19199 to check cylinder bores for wear. Measure cylinder bore at 6 points as shown, **Fig. 2**. Measure each cylinder bore at 90° angles near the top (2), middle (3) and bottom (4) of piston ring travel as shown.

If cylinder bore is worn more than **0.003" (0.076 mm)** or more than **0.0015" (0.038 mm)** out-of-round, it must be resized.

**NOTE:** If cylinder bores are within specification and show no signs of scoring or damage, new piston rings may be installed providing the cylinder bores are reconditioned to restore the proper crosshatch finish. Correct cylinder bore finish ensures proper lubrication and piston ring break in.



**Fig. 2**

### Resizing Cylinder

Verify the available piston oversize(s) for the engine being worked on. Resize the cylinder to exactly that dimension over the standard bore size. If this is done accurately, the oversize rings and pistons will fit correctly, maintaining proper clearances.

Cylinders should be resized with a good quality hone such as Briggs & Stratton Tool #19205. Contact your Briggs & Stratton source of supply for more information. Use the stones and lubrication recommended by the hone manufacturer to produce the correct cylinder finish.

**NOTE:** Automatic transmission fluid is an acceptable honing oil. Another acceptable honing oil can be made by mixing 4 parts 30 weight oil with 1 part kerosene.

If a boring bar is used, a hone must be used after the boring operation to produce the proper cylinder crosshatch finish.

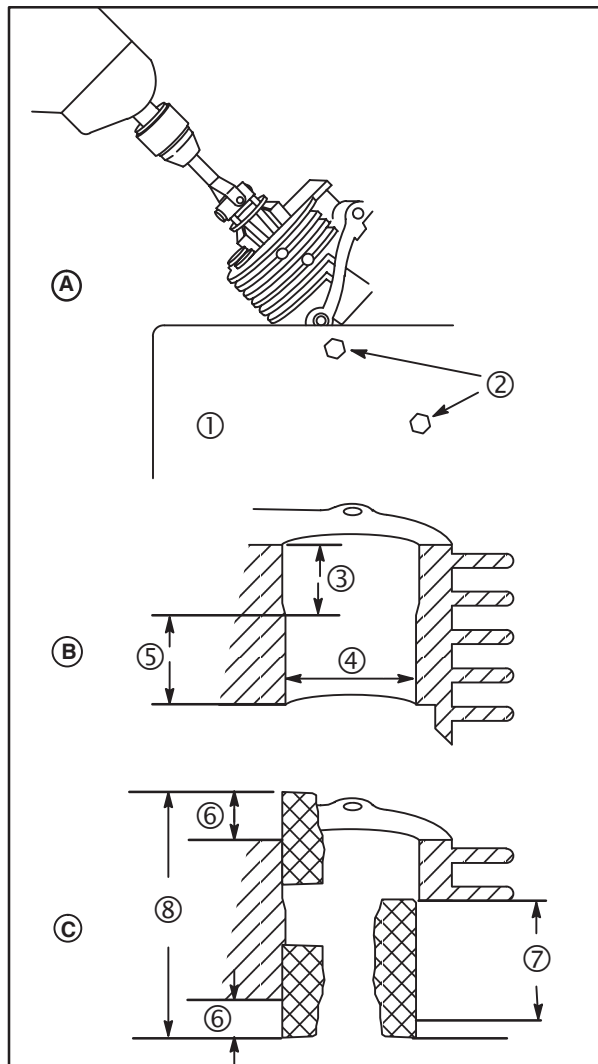
Honing can be done with a variable speed 1/2", portable drill and a honing fixture. See Section 13 for dimensions to make your own honing fixture.

1. Use crankcase cover mounting screws (2) to fasten cylinder to a honing fixture (1), **Fig. 3 (A)**.
2. Clamp honing fixture and cylinder securely in a vise at a convenient work height. Place hone drive shaft in chuck of portable drill and tighten.
3. Cut a wood block and place inside cylinder to prevent hone from extending further than **3/4 - 1" (19 - 25 mm)** below cylinder bore.
4. Place hone in middle of cylinder bore. Tighten adjusting knob with finger until stones fit snugly against cylinder wall. **DO NOT FORCE**. Connect drive shaft to hone. Be sure that cylinder and hone are centered and aligned with drive shaft and drill spindle.

**NOTE:** Recondition the cylinder bores to restore the crosshatch finish whenever new piston rings are installed to a cylinder that is within specification. Be careful not to hone the cylinder oversize or it will be necessary to resize the cylinder.

Lubricate hone as recommended by hone manufacturer. The recommended drill speed is **300 – 700 RPM** and **40 - 60 strokes per minute**. Because cylinder bores normally wear only in the area of ring travel (3), the cylinder bore will be round above and below ring travel area, **Fig. 3 (B)**. Start drill and, as hone spins, move it up and down (7) at the bottom of the cylinder bore (4). Gradually increase the length of the strokes until hone travels full length of cylinder bore (8), but no more than **3/4 – 1" (19 – 25 mm)** above or below (6) cylinder bore, **Fig. 3(C)**. Lubricate hone frequently to prevent build up on stones.

As cutting tension decreases, stop hone and tighten adjusting knob following hone manufacturer's recommendations. Check cylinder bore frequently.



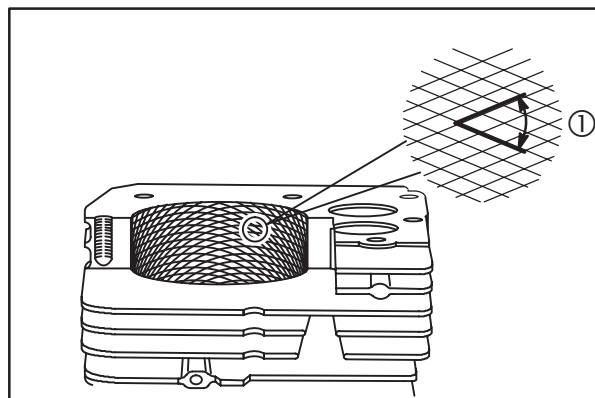
**Fig. 3**

## Finishing

Finishing stones are used after the cylinder bore has been resized to within **0.0015" (0.04 mm)** of the desired size or when reconditioning a cylinder bore. The finishing stones will produce the correct crosshatch finish necessary for proper lubrication. The correct crosshatch angle is approximately **45°** (1), **Fig. 4**.

Recondition the cylinder bores to restore the finish when new piston rings are to be installed in a cylinder that is within specification. Do not to hone oversize or it will be necessary to resize the cylinder.

**NOTE:** To produce the proper crosshatch finish use a drill speed of approximately **200 RPM** and **40 - 60 strokes per minute**. Lubricate hone liberally to prevent build up on finishing stones.



**Fig. 4**

## Cleaning

**CAUTION:** Honing grit is highly abrasive and will cause rapid wear to all the internal components of the engine unless it is completely removed. The entire cylinder and crankcase **MUST** be **THOROUGHLY** cleaned after honing.

First wash the cylinder and crankcase carefully in a solvent such as kerosene or commercial solvent. Then thoroughly wash cylinder and crankcase using a stiff brush with soap and hot water. Rinse thoroughly with hot running water. Repeat washing and rinsing until all traces of honing grit are gone.

**NOTE:** When cylinder and crankcase have been thoroughly cleaned, use a clean white rag or napkin to wipe the cylinder bore. If honing grit is present it will appear as a gray residue on rag. If any honing grit is evident, re-wash and rinse entire cylinder and crankcase and check again. When there is no trace of honing grit on rag, the cylinder has been properly cleaned. Oil the cylinder bore to prevent rusting.



## ENGINE BEARINGS

### Mag Bearing – After 970430xx

#### Check

1. Check magneto bearing for damage. Check for wear at several locations using plug gauge #19219 (1) or appropriate measuring tools, Fig. 5. If plug gauge is not available see reject dimension in Section 13.
2. Replace bearing if damaged or worn.

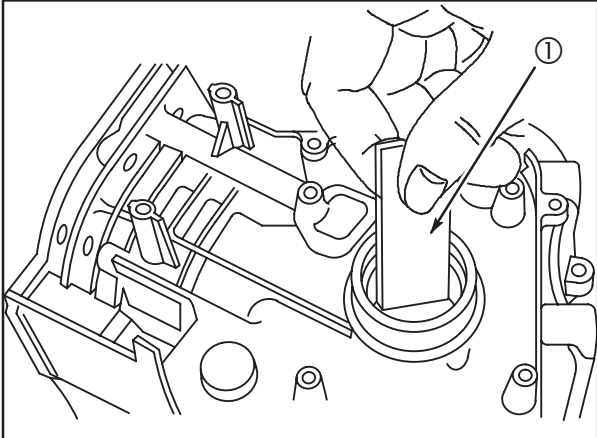


Fig. 5

#### Remove

1. Remove the oil seal.
2. Insert Bushing Driver #19450 (1) into bearing from oil seal side, Fig. 6.
3. Place a reference mark (2) on driver to indicate proper depth when installing new bearing.

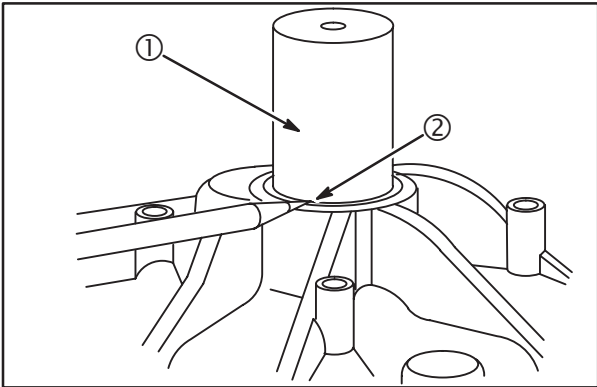


Fig. 6

4. Place cylinder on Cylinder Support #19227 with large opening facing bearing.
5. Press out bearing with bushing driver (1), Fig. 7.

#### Install

1. Place cylinder on Cylinder Support #19227 with large opening facing bearing, Fig. 7.
2. Align oil holes in bearing with oil holes in cylinder.
3. Press in new bearing to correct depth with bushing driver (1).

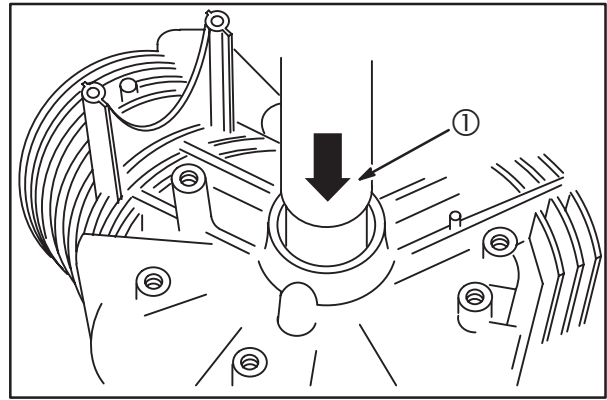


Fig. 7

4. Stake bearing in top notch (2) with 1/8" round pin punch to prevent bearing from turning, Fig. 8.

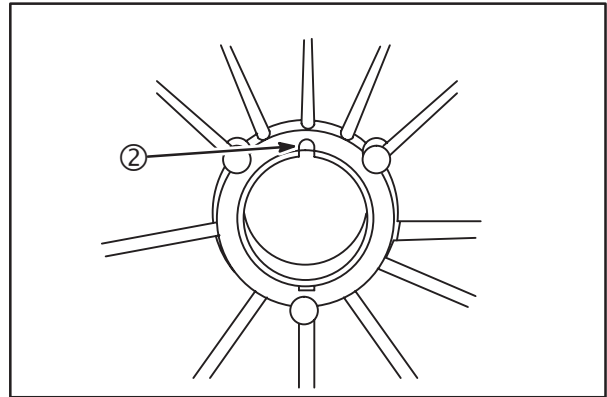


Fig. 8

5. Install new oil seal with sealing lips facing in. Use Cylinder Support #19227. Press oil seal until flush with cylinder.

### Mag Bearing – Before 970501xx

#### Check

1. Check magneto bearing for damage. Check for wear at several locations using #19380 plug gauge or appropriate measuring tools, Fig. 9. If plug gauge is not available see reject dimension in Section 13.
2. Replace bearing if damaged or worn.

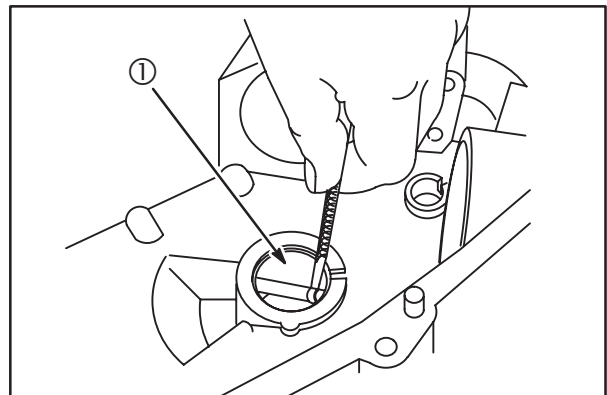


Fig. 9

Insert Bushing Driver #19349 into bearing from oil seal side. Place a reference mark on driver to indicate proper depth of bushing when installing new bearing, as shown, Fig. 6.

### Remove

The magneto bearing has a roll pin installed in the oil gallery to prevent the bearing from turning.

1. Drive roll pin (2) into oil gallery using a 3/16" punch (1), Fig. 10.
2. Place cylinder on Cylinder Support #19227 with large opening facing bearing.
3. Press out bearing with Bushing Driver #19349.

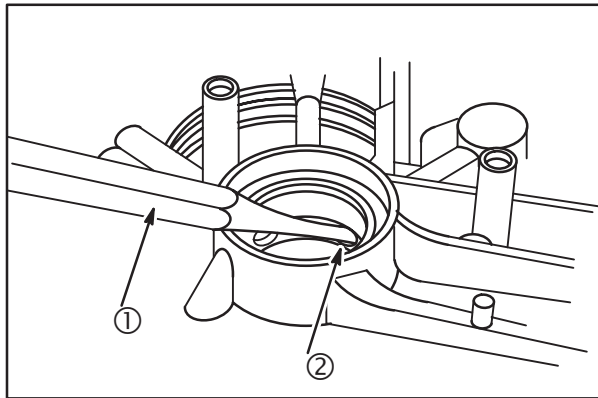


Fig. 10

### Install

1. Place cylinder on Cylinder Support #19227 with large opening facing bearing.
2. Align oil holes in bearing with oil holes in cylinder.
3. Press in new bearing to correct depth with Bushing Driver #19349 (3), Fig. 11.

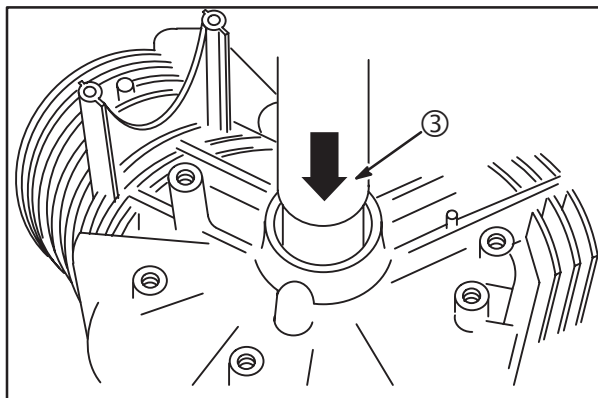


Fig. 11

4. Grind off the taper (5), approximately 1/8" (3 mm) (4), from one end of new roll pin as shown, Fig. 12.
  - a. Quench pin in water periodically to prevent loss of temper.
  - b. Remove all burrs and clean thoroughly.

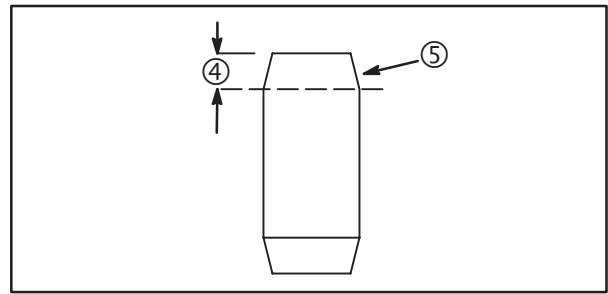


Fig. 12

5. Place TAPERED end of new roll pin in the bearing oil hole.
6. Use Roll Pin Driver #19344 to install new roll pin, Fig. 13. Drive in new roll pin until tool bottoms.
7. Use Cylinder Support #19227 and press oil seal until flush with cylinder.

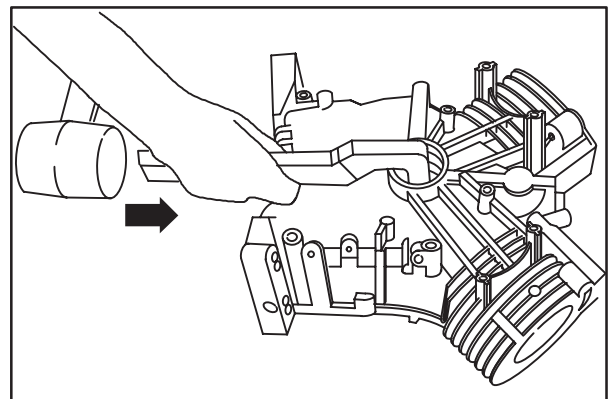


Fig. 13

## PTO Ball Bearing

### Check

Ball bearings must rotate freely, Fig. 14. If any rough spots are felt replace the ball bearing.

• **CAUTION:** Crankcase cover bearings are usually damaged during removal from the crankcase. Do not re-use crankcase cover bearings.

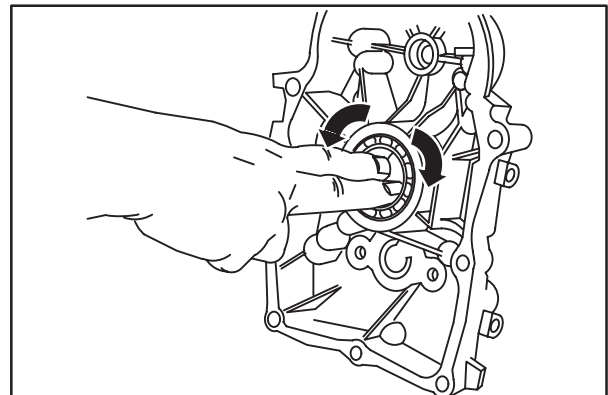
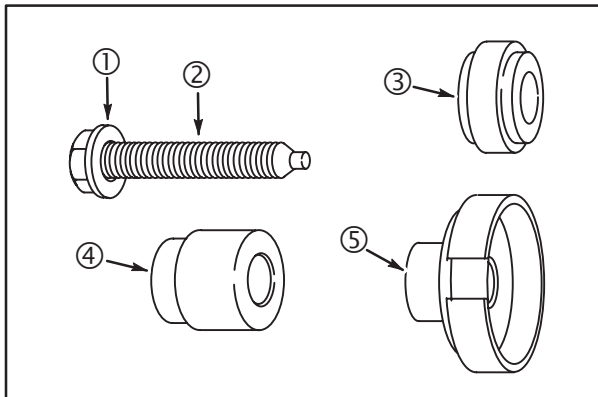


Fig. 14

The following tools are recommended to replace the ball bearing, **Fig. 15**.

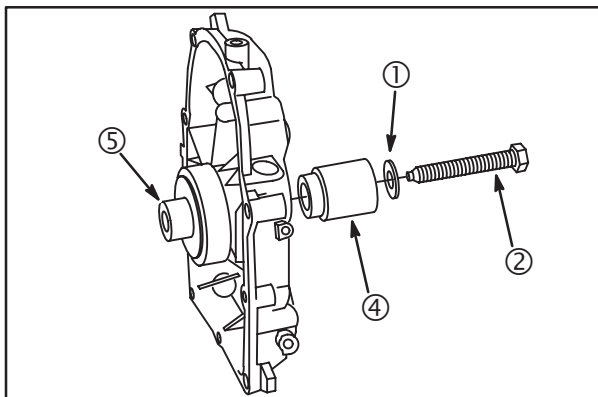
- (1) Washer #224061
- (2) Puller Screw #19318
- (3) Pilot #19396
- (4) Driver #19401
- (5) Support #19440



**Fig. 15**

### Remove

1. Assemble washer (1), to puller screw (2). Insert through large end of driver (4), **Fig. 16**.
2. Place open side of support (5), over ball bearing.
3. Insert screw with driver through ball bearing and thread into support. Continue tightening screw until ball bearing is removed.



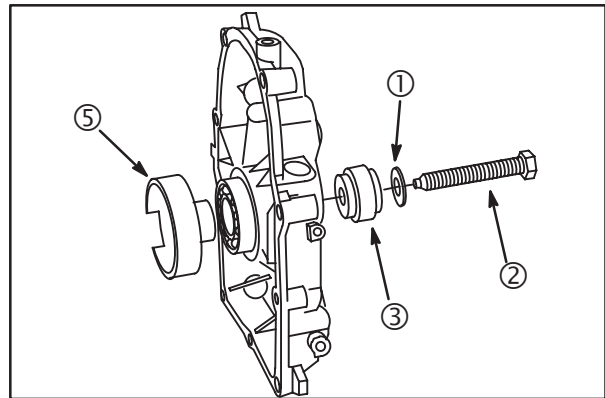
**Fig. 16**

### Install

Lubricate outside diameter of ball bearing before installing.

1. Place ball bearing on to Support #19440, **Fig. 17**.
2. Assemble washer (1), to puller screw (2).

3. Insert screw (2) and washer (1) through pilot (3) and thread into support (5). Tighten screw until bearing is seated.
4. Use Cylinder Support #19227 and press oil seal until flush with crankcase cover.



**Fig. 17**

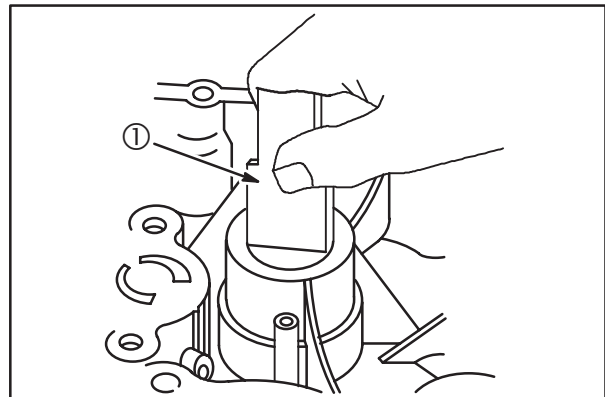
### PTO Plain Bearing

Replace the sump if the PTO bearing is scored or if Plug Gauge #19380 (1), enters bearing. Try gauge at several locations in bearing, **Fig. 18**.

If plug gauge is not available, measure the bearing ID at several points. Replace the cover or sump if the bearing ID exceeds 1.381" (35.07 mm) (Model 540000 – 1.777" (45.12 mm)) at any point.

### Oil Seal

When installing new PTO oil seal, use 1-7/8" (47.6 mm) side of Cylinder Support #19227. Press in seal until it is 1/16" (1.5 mm) below mounting surface.



**Fig. 18**

### Camshaft Bearings

Use Plug Gauge #19384 to check magneto side cam bearing. Use Plug Gauge #19386 to check PTO side cam bearing. Plug gauge should not enter bearing. If plug gauges are not available, see reject sizes in Section 13. If cam bearings are worn, cylinder or crankcase cover must be replaced.

# Section 10

## Crankshafts and Camshafts

---

	Page
INSPECT CAMSHAFT .....	156
INSPECT CRANKSHAFT .....	156
INSPECT FLYWHEEL .....	157

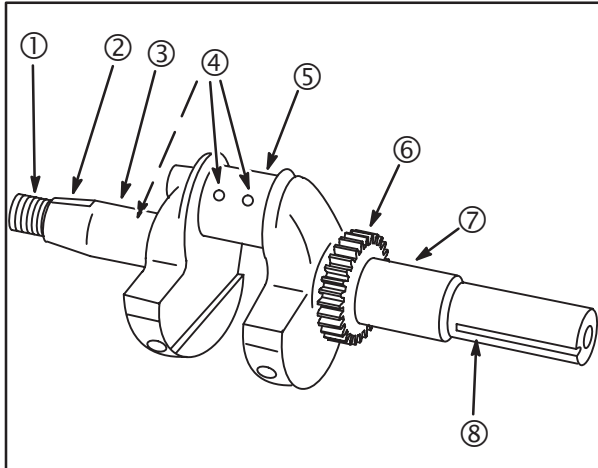
## INSPECT CRANKSHAFT

Inspect crankshaft threads (1) and keyways (2, 8), **Fig. 1**. Replace crankshaft if threads or keyways are damaged or worn. Check magneto (3) and PTO (7) journals for scoring. Measure journals for wear. Replace crankshaft if journals are scored, or worn past reject sizes listed in Section 13.

Check oil galleries (4) for blockage or obstructions.

Inspect timing gear (6). Replace timing gear if teeth are damaged or worn.

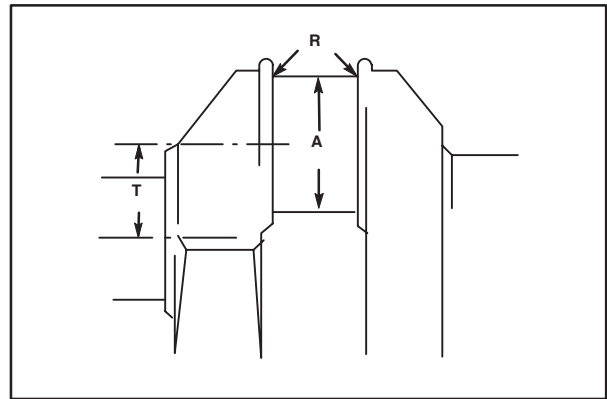
Measure crankpin (5) for wear.



**Fig. 1**

Crankshaft crankpin may be re-ground for **0.020"** undersize connecting rods when available. See IPL for part number. Accurately measure and grind the crankpin diameter (A), throw (T) and fillet radius (R), **Fig. 2**. Discard any crankshaft that is worn beyond reject specifications listed in Section 13.

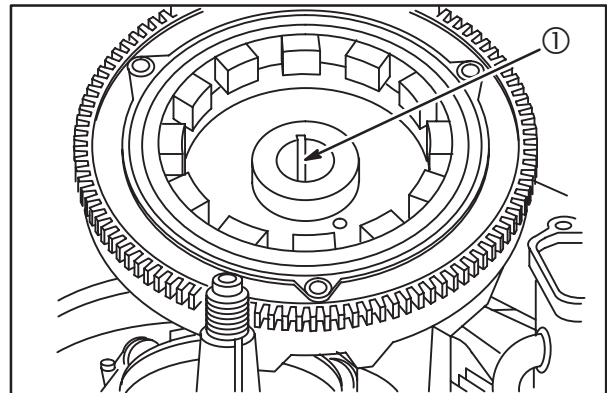
Complete instructions are included with undersize connecting rods.



**Fig. 2**

## INSPECT FLYWHEEL

Check flywheel keyway (1) for damage. Replace flywheel if it has cracks, broken fins or keyway damage, **Fig. 3**.



**Fig. 3**

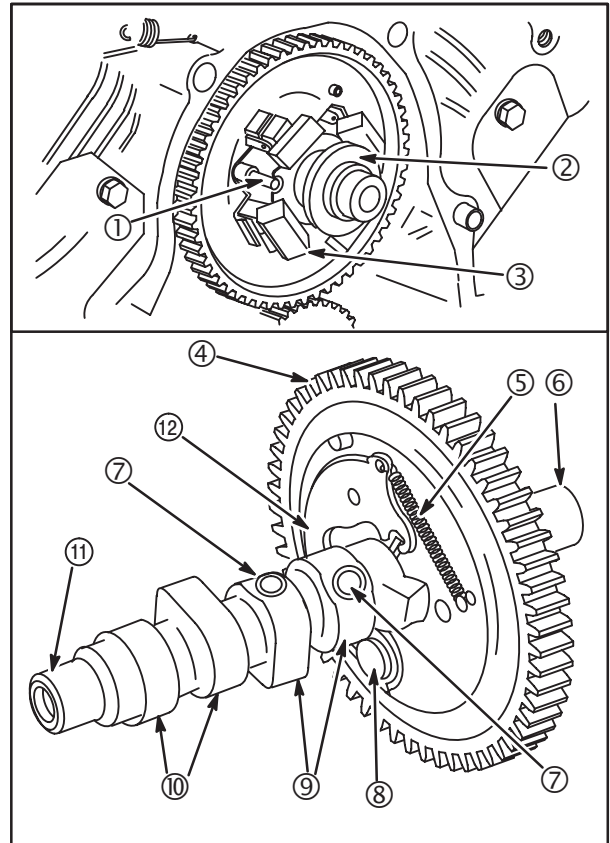
## INSPECT CAMSHAFT

Inspect gear teeth (4), lobes (9, 10), compression release balls (7) and camshaft bearing journals (6, 11) for wear and nicks, **Fig. 4**.

Camshaft journal and lobe reject sizes are shown in specifications page in Appendix. Replace cam gear if not to specification.

Governor spool (2) must move freely on PTO journal (6) of camshaft. Flyweight (12) must move freely on pivot (8). Make sure flyweight spring (5) is not stretched. Governor weights (3) must move freely on hinge pins (1). Make sure hinge pins are not loose.

If parts are worn or damaged replace camshaft assembly.



**Fig. 4**



# Section 11

## Pistons, Rings and Connecting Rods

---

	Page
ASSEMBLE PISTON AND CONNECTING ROD .....	161
ASSEMBLE RINGS TO PISTON .....	162
DISASSEMBLE .....	160
GENERAL INFORMATION .....	160
INSPECT PISTON AND PISTON RINGS .....	160
INSPECT PISTON PIN AND CONNECTING ROD .....	161



## GENERAL INFORMATION

Install new piston rings whenever the engine is disassembled for major servicing or overhaul, providing that cylinder bores are within specification.

1. Remove any carbon or ridge at the top of the cylinder bore. This will prevent breaking the rings when removing the piston and connecting rod from the engine.
2. Remove the connecting rod cap. Push the piston and connecting rod out through the top of the cylinder.
3. Measure cylinder bores before checking pistons and rings. If cylinder bores require re-sizing it is not necessary to check pistons and rings, since a new oversized piston assembly will be used.

Resize a cylinder bore if it is more than **0.003" (0.08 mm)** oversize, or **0.0015" (0.04 mm)** out of round.

### Disassemble

1. Remove piston rings using Ring Expander #19340 (1), Fig. 1.
2. Remove oil control ring coil expander and oil control rings.

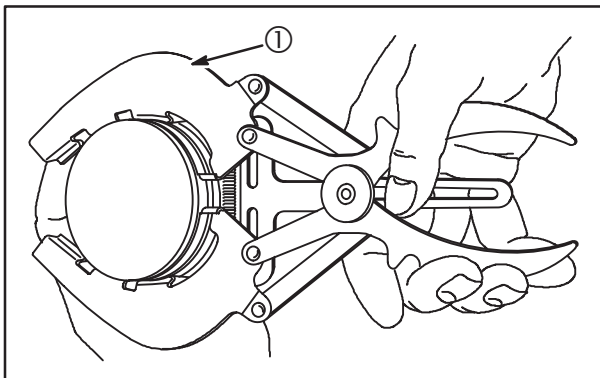


Fig. 1

3. Disassemble piston from connecting rod, Fig. 2.
  - a. Remove piston pin locks (2).
  - b. Piston pin is a slip fit in piston and connecting rod.

Keep pistons and connecting rods together as an assembly. Do not mix.

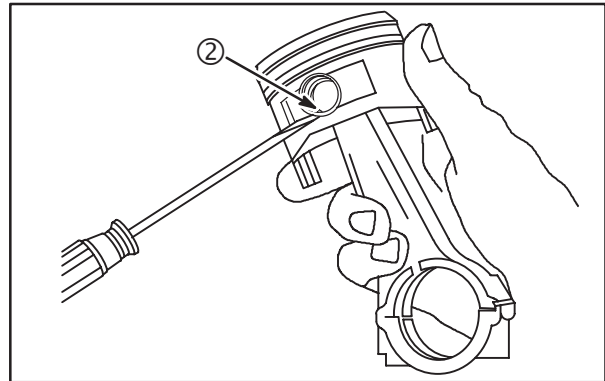


Fig. 2

### Inspect Piston and Piston Rings

**NOTE:** If the cylinder is not going to be resized and the piston shows no signs of scoring, the piston should be checked.

1. Check side clearance of ring grooves using a feeler gauge and NEW piston rings (3), Fig. 3. Replace the piston if the ring groove is worn beyond specification.

Side Clearance Reject Dimension:

#### All Except Models 540000, 610000

- Compression Rings – **0.004" (0.10 mm)**
- Oil Rings – **0.008" (0.20 mm)**

#### Models 540000, 610000

- Top Compression Ring – **0.009" (0.23 mm)**
- Center Compression Ring – **0.006" (0.15 mm)**
- Oil Rings – **0.004" (0.10 mm)**

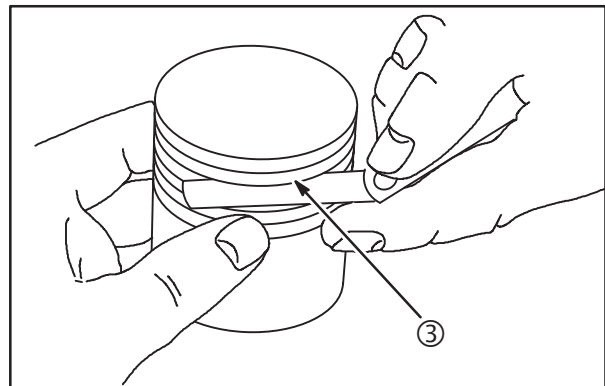


Fig. 3

2. Check ring end gap, Fig. 4. Clean carbon from end of rings and insert approximately **1" (25 mm)** into cylinder.

End Gap Reject Dimension

#### All Except Models 540000, 610000

- All Rings – **0.030" (0.76 mm)**

### Models 540000, 610000

- Top Compression Ring – **0.030" (0.76 mm)**
- Center Compression Ring – **0.030" (0.76 mm)**
- Oil Rings – **0.040" (1.0 mm)**

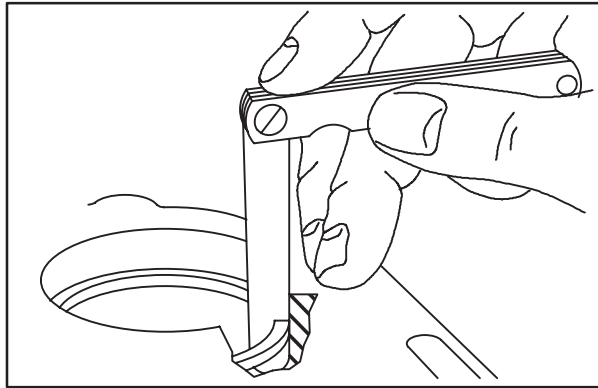


Fig. 4

3. Check piston pin bore, **Fig. 5**. Replace piston if worn beyond reject dimension or **0.0005" (0.01 mm)** out of round.

#### Piston Pin Bore Reject Dimension

- Models 290000 – 351000 – **0.674" (17.12 mm)**
- Model 380000 – **0.711" (18.06 mm)**
- Model 540000 – **0.828" (21.03 mm)**

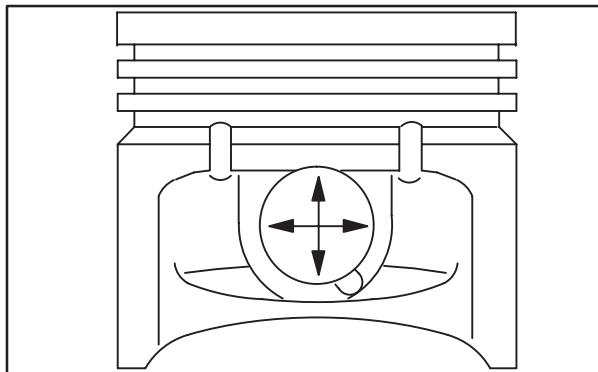


Fig. 5

### Inspect Piston Pin and Connecting Rod

1. Measure piston pin, **Fig. 6**. Replace pin if worn beyond reject dimension or **0.0005" (0.01 mm)** out of round.

#### Piston Pin Reject Dimension:

- Models 290000 – 351000 – **0.672" (17.07 mm)**
- Model 380000 – **0.708" (17.98 mm)**
- Model 540000 – **0.826" (20.98 mm)**

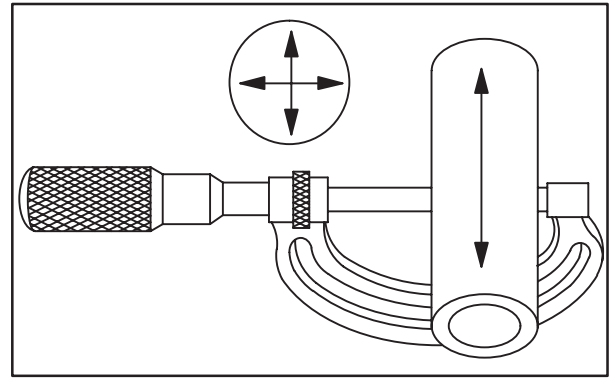


Fig. 6

2. Check connecting rod bearings, **Fig. 7**.

**NOTE:** Undersize (**0.020"**) connecting rods are available for use on a reground crankpin journal on some engines. See IPL for availability. If crankpin bearing is scored or worn replace the connecting rod.

#### Piston Pin Bearing (1) Reject Dimension

- Models 290000 – 351000 – **0.674" (17.12 mm)**
- Model 380000 – **0.711" (18.06 mm)**
- Model 540000 – **0.828" (21.03 mm)**

#### Crankpin Bearing (2) Reject Dimension

- All Except Model 540000 – **1.461" (37.12 mm)**
- Model 540000 – **1.658" (42.11 mm)**

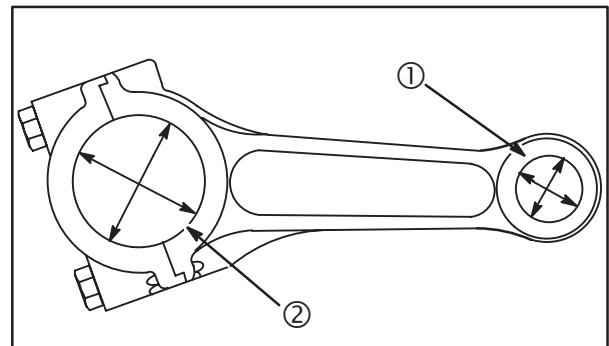
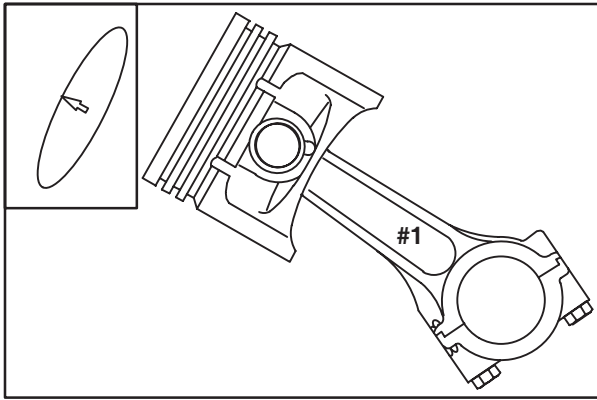


Fig. 7

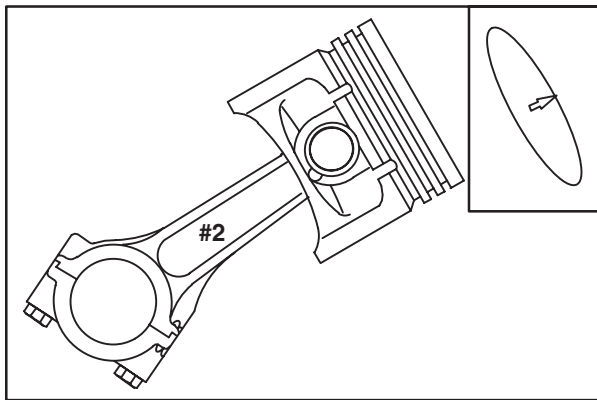
### Assemble Piston and Connecting Rod

1. Lubricate parts with engine oil. Assemble #1 piston to connecting rod, **Fig. 8**.
2. Arrow, notch or casting mark on piston must face flywheel side, inset **Fig. 8**.
  - The designation "OUT 1" or the number "1" on the connecting rod must face PTO side (opposite arrow on piston).
  - Install piston pin locks with needle nose pliers.



**Fig. 8**

3. Lubricate parts with engine oil. Assemble #2 piston and connecting rod, **Fig. 9**.
  - Arrow, notch or casting mark on piston must face flywheel side.
  - The designation "OUT 2" or the number "2" on the connecting rod must face PTO side (opposite arrow on piston).
4. Install piston pin locks with needle nose pliers.

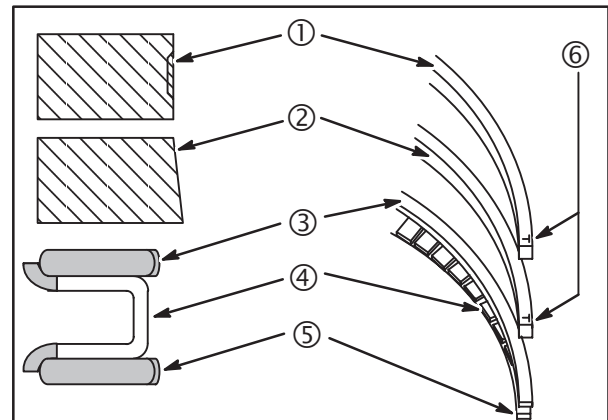


**Fig. 9**

## Assemble Piston Rings to Piston

Install rings in order shown, **Fig. 10**. Use Piston Ring Expander, #19340 when installing center (2) and top (1) compression rings.

1. Install oil ring expander (4).
  - a. Install lower scraper ring (5).
  - b. Install upper scraper ring (3).
2. Install center compression ring (2) with ID mark (6) up.
3. Install top compression ring (1) with ID mark (6) up.



**Fig. 10**

# Section 12

## Engine Assembly

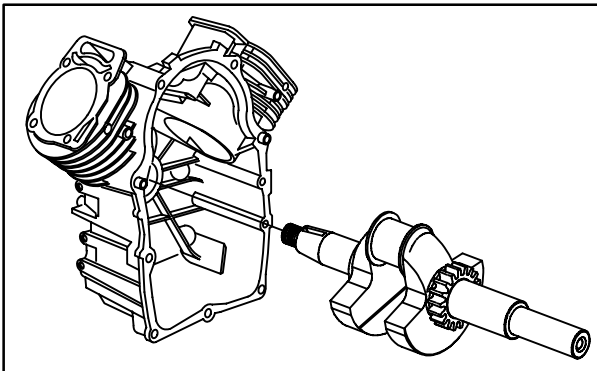
---

	Page
<b>ENGINE ASSEMBLY</b> .....	<b>164</b>
Install Crankshaft .....	164
Install Piston and Connecting Rod .....	164
Install Camshaft .....	164
Install Oil Pump .....	165
Install Crankcase Cover or Sump .....	165
Install Cylinder Heads .....	166
Install Rocker Arms .....	166
Install Push Rods .....	166
Install Starter Motor, Breather, Alternator .....	167
Install Flywheel .....	167
Flywheel – All Models Except POWERLINK™ .....	167
Flywheel – POWERLINK™ .....	168
Torque Flywheel Nut – 290000, 300000, 540000, 610000 .....	167
Torque Flywheel Nut – 350000, 380000 .....	168
Install Fan – 350000, 380000 .....	168
Install Armatures .....	169
Install Control Bracket .....	169
Install Carburetor and Manifold .....	169
Vertical Crankshaft .....	169
Horizontal Crankshaft .....	170
Install Blower Housing .....	172
Install Air Cleaner .....	172
Vertical Crankshaft .....	172
Horizontal Crankshaft .....	173
Final Engine Assembly .....	175
Static Governor Adjustment .....	175

## ENGINE ASSEMBLY

### Install Crankshaft

Lubricate mag bearing and lips of oil seal with engine oil. Install crankshaft, **Fig. 1**.

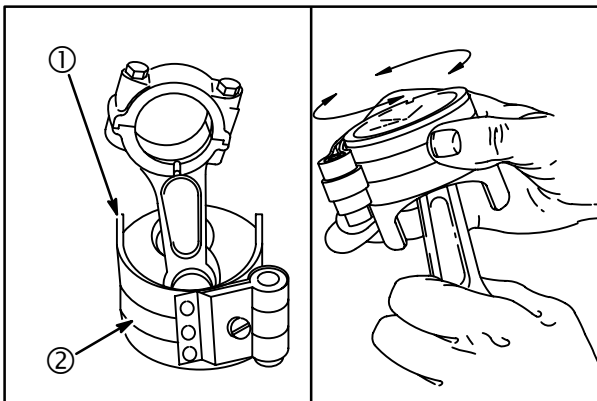


**Fig. 1**

### Install Piston and Connecting Rods

**NOTE:** Install #1 piston and connecting rod first.

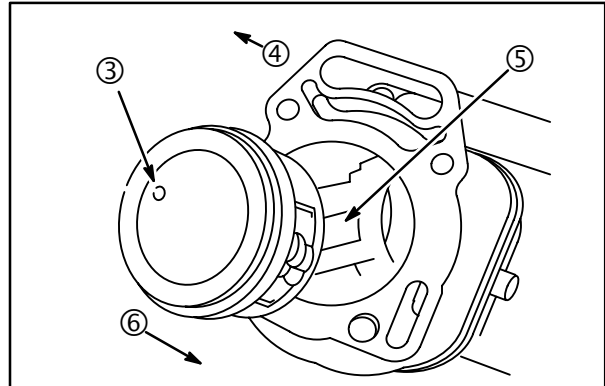
1. Oil piston rings and piston skirt. Compress rings with Piston Ring Compressor #19070 (2), **Fig. 2**.
  - a. Place piston and ring compressor upside down on bench with projections (1) on compressor facing up.
  - b. Tighten ring compressor until rings are fully compressed.
  - c. Loosen ring compressor slightly so the compressor can be rotated on the piston skirt while holding connecting rod.



**Fig. 2**

2. Lubricate cylinder bores and crankpin. Rotate crankshaft until it is at bottom of stroke.
3. Install #1 piston with notch or offset casting mark (3) toward the FLYWHEEL SIDE of the engine (4), **Fig. 3**. Push piston down by hand until connecting rod is seated on crankpin.

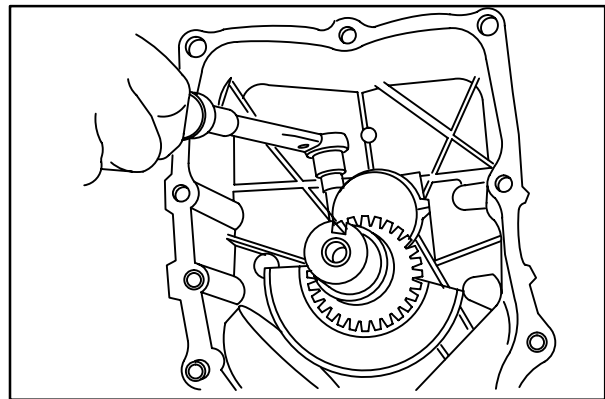
**NOTE:** The words "OUT-1" (5) on #1 connecting rod must be facing PTO side of engine (6).



**Fig. 3**

4. Assemble connecting rod cap to rod with match marks aligned, **Fig. 4**. Torque screws to **115 in. lbs. (13 Nm)**.

**NOTE:** Models 540000, 610000 – **125 in. lbs. (14 Nm)**.



**Fig. 4**

5. Rotate crankshaft **two revolutions** to check for binding. Connecting rod should also be free to move sideways on crankpin.
6. Repeat for #2 cylinder.

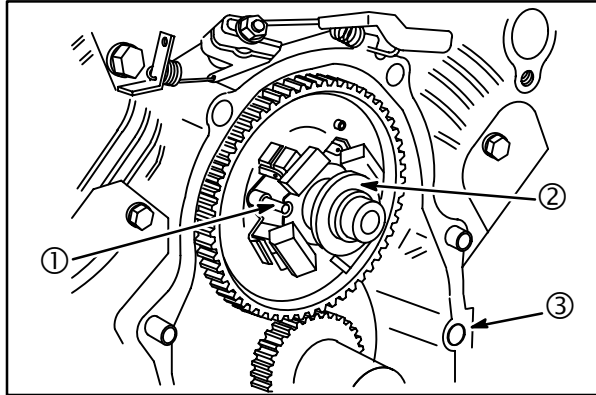
**NOTE:** The words "OUT-2" on #2 connecting rod must face PTO side.

**CAUTION:** Failure to use a torque wrench can result in loose connecting rod screws causing breakage, or overtightened connecting rod screws, causing scoring.

### Install Camshaft

1. Lubricate tappets, camshaft journals and lobes with engine oil. Assemble timing gear to crankshaft.
2. Install tappets.

3. Align timing marks on camshaft and crankshaft timing gear. Install camshaft, **Fig. 5**.
4. Assemble governor spool (2) to camshaft (except Models **540000, 610000**).
  - a. Install new O-ring (3) in cylinder.
  - b. Make sure that spool engages flyweights and slot on spool fits over locating pin (1).

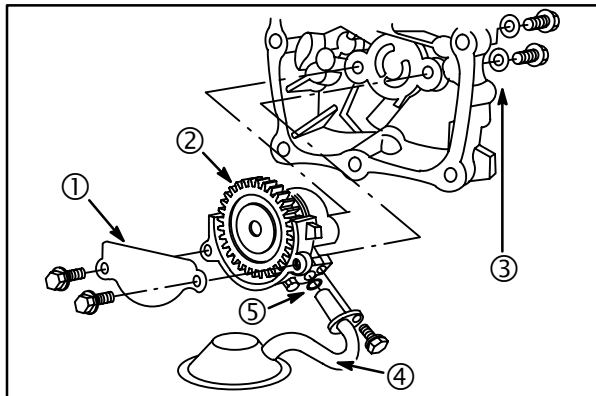


**Fig. 5**

## Install Oil Pump

### Horizontal Crankshaft

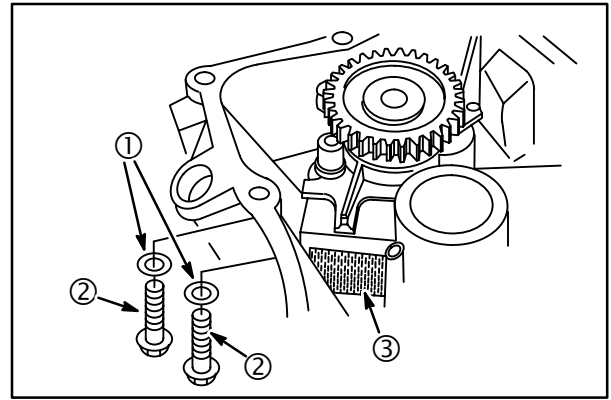
1. Install a new O-ring (5) to the pickup tube and screen assembly (4). Install the pickup tube assembly to the oil pump (2), **Fig. 6**.
2. Install oil pump assembly and gear baffle (1), to crankcase. Use new O-rings (3) under the screws.



**Fig. 6**

### Vertical Crankshaft

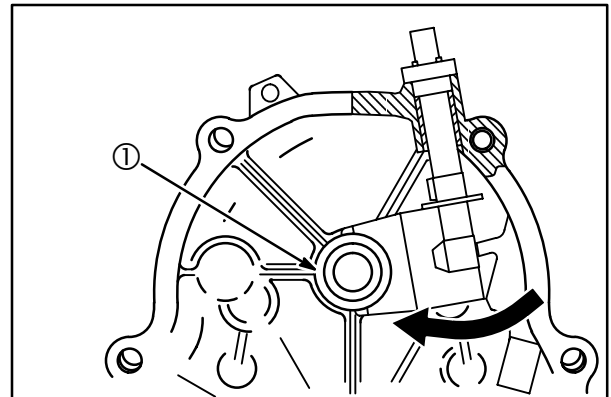
1. Make sure the oil pickup screen (3) is clean and in position.
2. Place new O-rings (1) on the screws (2). Install to sump, **Fig. 7**.



**Fig. 7**

## Install Crankcase Cover or Sump

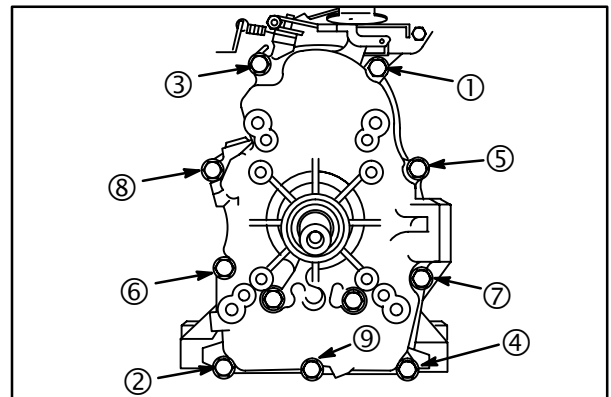
1. Lubricate PTO and camshaft bearing.
2. Rotate governor shaft so that paddle rests against camshaft bearing support, **Fig. 8**.
3. Insert proper seal protector through oil seal.



**Fig. 8**

4. Install crankcase cover or sump with new gasket. Torque screws in sequence, **Fig. 9**, to **150 in. lbs. (17 Nm)**.

**NOTE:** Models **540000, 610000** – **200 in. lbs. (23 Nm)**.



**Fig. 9**

5. Check crankshaft end play. End play should be **0.003 – 0.015" (0.08 – 0.40 mm)**.

Crankshaft end play is adjusted by adding or removing a thrust washer. Thrust Washer Kit #807625 contains shims with the following thickness; **0.039" (1.0 mm)**, **0.049" (1.25 mm)** and **0.059" (1.5 mm)**. The thrust washer is installed on the PTO side of the crankshaft next to the timing gear.

## Install Cylinder Heads

1. Install cylinder head with new gasket, **Fig. 10**.

**NOTE:** Engines manufactured before 940501xx were equipped with sealing washers under #1 and #3 cylinder head bolts.

2. Lubricate threads of head bolts with Valve Guide Lubricant #93963.
3. Torque bolts in sequence shown to **165 in. lbs. (19 Nm)**.

**NOTE:** Models 540000, 610000 – **350 in. lbs. (40 Nm)**

4. Insert push rods into recess in tappets.

**NOTE:** All Models **except 540000, 610000** – Exhaust valve push rods are aluminum. Models **540000, 610000** – All push rods are aluminum.

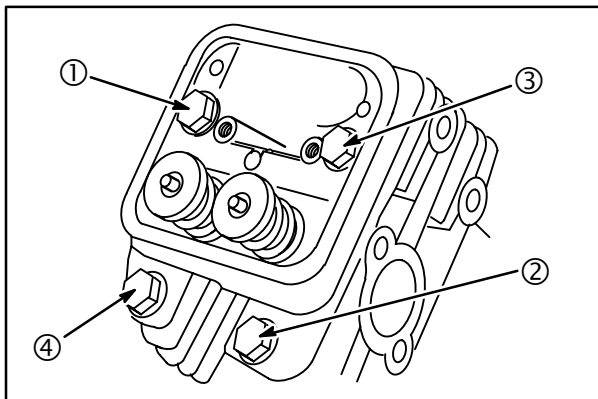


Fig. 10

## Install Rocker Arms

### Current Style

1. Lubricate rocker arm supports (2) with clean engine oil.

2. Assemble rocker studs (1), rocker arm supports and rocker arms (3) to cylinder head, **Fig. 11**.
3. Torque studs to **100 in. lbs. (11 Nm)**.

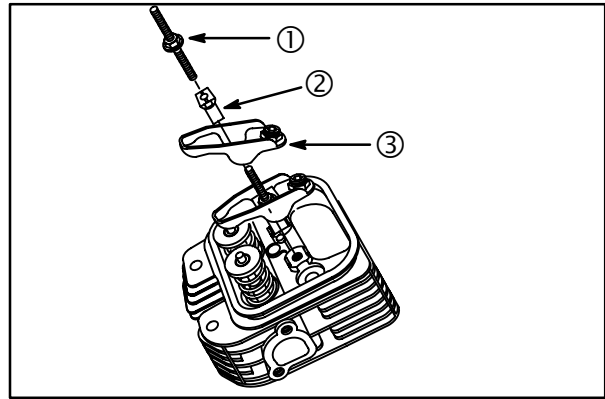


Fig. 11

### Early Style

**NOTE:** Rocker shaft support (3) holes are offset. Install with holes facing ends of rocker shaft, **Fig. 12**.

1. Lubricate rocker arms (4) and shaft (2) with clean engine oil.
2. Assemble rocker arms, shaft, supports and studs (1) and install on cylinder head, **Fig. 12**.
3. Torque studs to **140 in. lbs. (16 Nm)**.

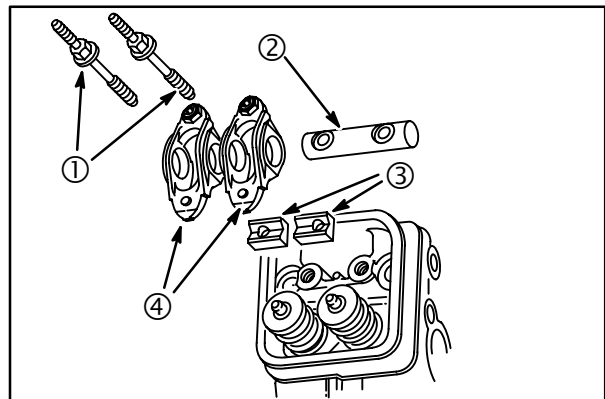


Fig. 12

## Install Push Rods

1. Compress valve spring (3) with rocker arm (2) and insert push rod (1) into rocker arm socket, **Fig. 13**.

**NOTE:** Be sure push rods remain seated in recess in tappets.

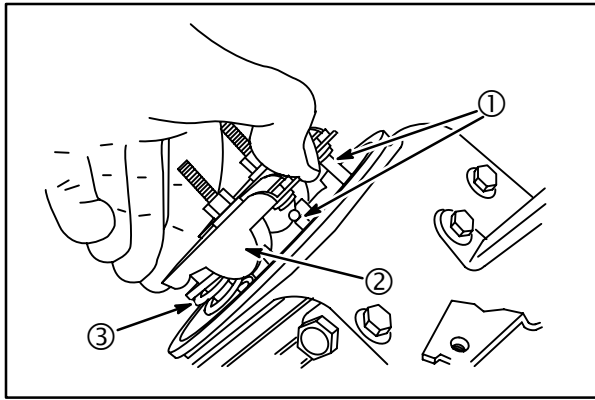


Fig. 13

2. Install valve covers with new gaskets and valve cover seals (6), Fig. 14. Torque nuts (7) to **25 in. lbs. (3 Nm)**.

**NOTE:** Models 540000, 610000 – **70 in. lbs. (8 Nm)**

3. Repeat for No. 2 cylinder.
4. Adjust valve clearance. See Section 1.

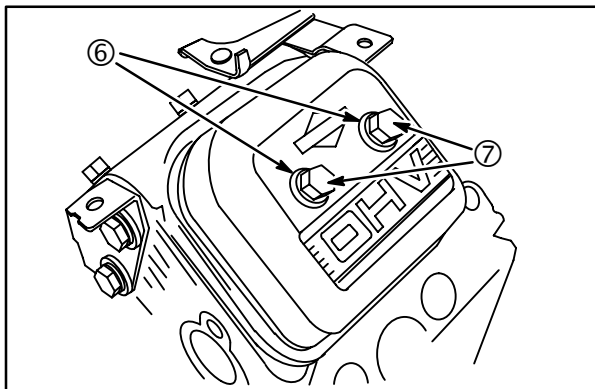


Fig. 14

### Install Starter Motor, Breather, Alternator

1. Install back plate (1), Fig. 15. Torque screws to **65 in. lbs. (7 Nm)**.
2. Install alternator (2). Torque screws to **20 in. lbs. (2 Nm)**.

**CAUTION:** Route alternator wire(s) behind starter motor. DO NOT pinch wires.

3. Install starter motor (3). Torque screws to **140 in. lbs. (16 Nm)**.
4. Install breather, Models 290000 – 350000. Torque screws to **30 in. lbs. (3 Nm)**.

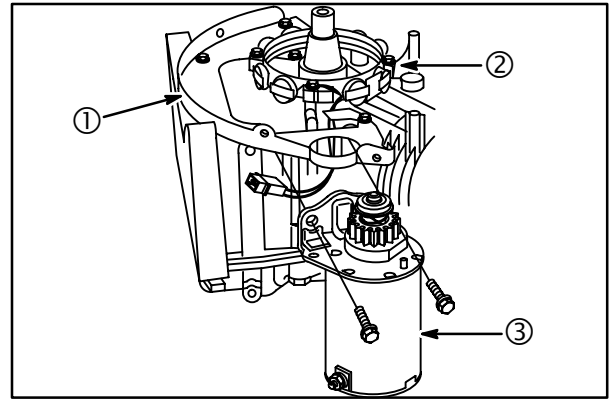


Fig. 15

### Install Flywheel

All models except Engines with POWERLINK™

**CAUTION:** Clean flywheel and crankshaft taper. Remove ALL oil, dirt and grease.

1. Assemble flywheel to crankshaft and align keyways.
2. Insert flywheel key into crankshaft.

### Torque Flywheel Nut

Models 290000, 303000, 540000, 610000

1. Install starter hub (if equipped), washer and flywheel nut.
2. Place Flywheel Strap Wrench #19433 (1) around outer rim of flywheel, Fig. 16.
3. Use torque wrench (2) to torque flywheel nut to **125 ft. lbs. (175 Nm)**. Models 290000, 303000 and 150 ft. lbs. (203 Nm). Models 540000 and 610000.

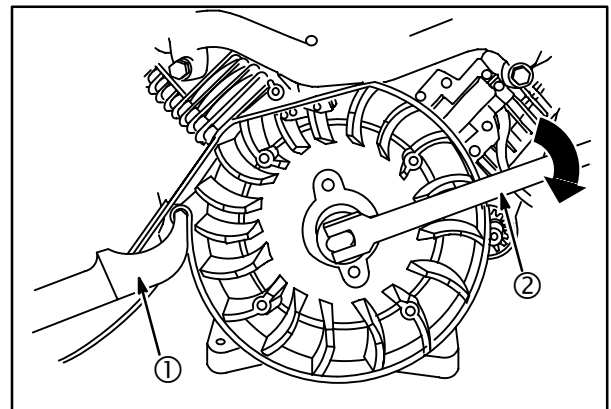


Fig. 16



## Models 350000, 380000

1. Install washer and flywheel nut.
2. Assemble Flywheel Holder #19321 (2) to retainer, Fig. 17.
3. Use a torque wrench (1) and 30 mm socket (3) to torque flywheel nut to **125 ft. lbs. (175 Nm)**.
4. Install starter hub and screw (if equipped). Torque to **35 ft. lbs. (48 Nm)**.

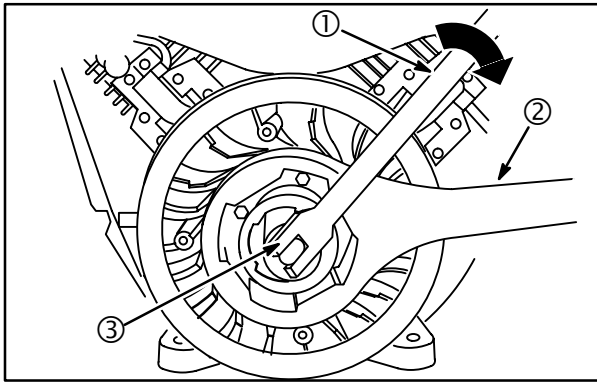


Fig. 17

## Install Fan

### Models 350000, 380000

1. Align boss on back of fan (5) with notch (3) in flywheel, Fig. 18.

**NOTE:** Engines manufactured after date code 030430xx use a specially balanced crankshaft and balanced fan which has no boss. This fan can be mounted in any direction on the flywheel. Do not interchange fans or crankshafts manufactured before 030501xx with newer components.

2. Align cut out in retainer (6) with cut out in fan.
3. Torque screws (7) to **150 in. lbs. (17 Nm)**.

**NOTE:** Models **540000, 610000** torque screws to **90 in. lbs. (10 Nm)**.

4. If equipped, install rewind starter hub (2) and starter hub screw (1).

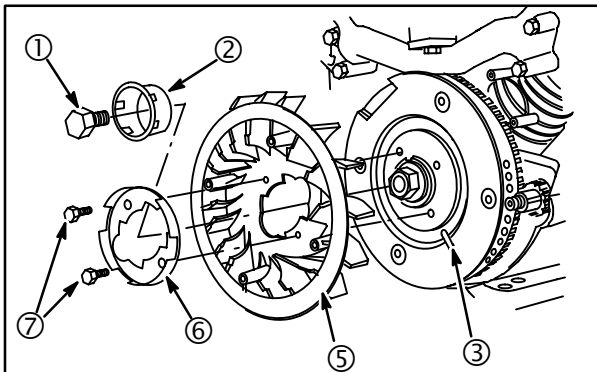



Fig. 18

## Install Flywheel – Engines with PowerLink™

**NOTE:** Before installing flywheel make sure the flywheel magnets are free of debris.

	<b>WARNING</b>
<b>AVOID HAND/FINGER INJURY.</b>	
<ul style="list-style-type: none"><li>• The flywheel magnets are <b>VERY POWERFUL</b> and can rapidly pull the flywheel to the engine.</li><li>• Be certain the puller screw (1) is set to <b>AT LEAST</b> the height it was at when the flywheel was removed from the engine.</li></ul>	

1. With pilot (2) installed to the crankshaft (3), place the flywheel with puller attached, onto the pilot, Fig. 19.
2. Align the flywheel keyway mark with the crankshaft key (4). Slowly loosen the flywheel puller screw (1) to lower the flywheel (5) into position over the stator. Be certain that the crankshaft key engages the flywheel keyway.

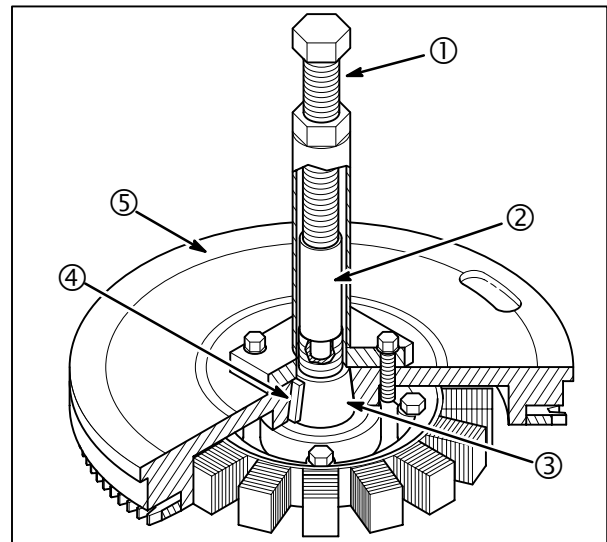


Fig. 19

3. Install the flywheel nut. Torque the flywheel nut to specification.
4. Reassemble the fan and fan retainer to the flywheel.
5. Connect the alternator wires to the regulator-rectifier.
6. Connect the **POWERLINK™** harness to the inverter and install tamper-proof screws.
7. Retest system to ensure proper operation.

## Install Armatures

1. Assemble armature to engine, **Fig. 20**.
2. Install ground wire onto tab terminal on armatures.

**NOTE:** Mounting holes in armature are slotted. Push armature away from flywheel (arrow) as far as possible. Tighten either screw (4) to hold armature in place.

3. Repeat for second armature.
4. Adjust armature air gap. See Section 1.

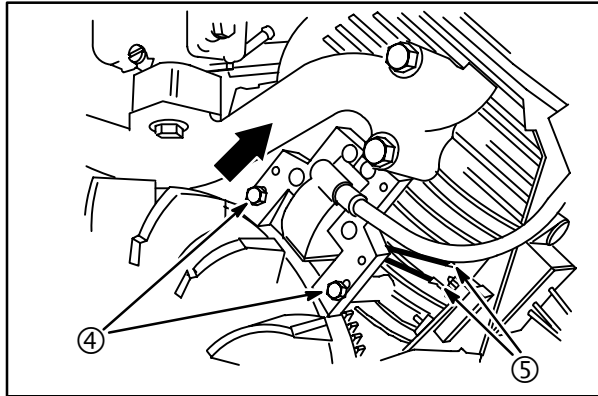


Fig. 20

## Install Control Bracket

1. Install cylinder shields (4) and valley cover (1), **Fig. 21**. Torque screws to **65 in. lbs. (7 Nm)**.

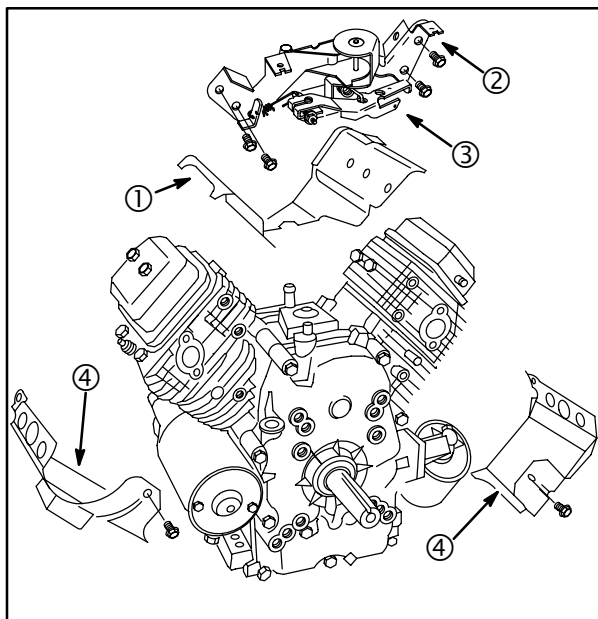


Fig. 21

2. Connect ground wire harness to stop switch terminal.

3. Assemble governor lever (3) to governor shaft. **DO NOT** tighten nut at this time.
4. Install governor control bracket (2). Torque screws to **140 in. lbs. (16 Nm)**.

## Install Carburetor and Manifold

### Vertical Crankshaft

Models 290700, 303700, 350700

#### Current style: Fig. 22

1. Assemble gaskets (1) and spacer (4) to manifold. Make sure that locating pin (2) on carburetor spacer fits in recess (3) in manifold.
2. Assemble carburetor onto mounting studs.

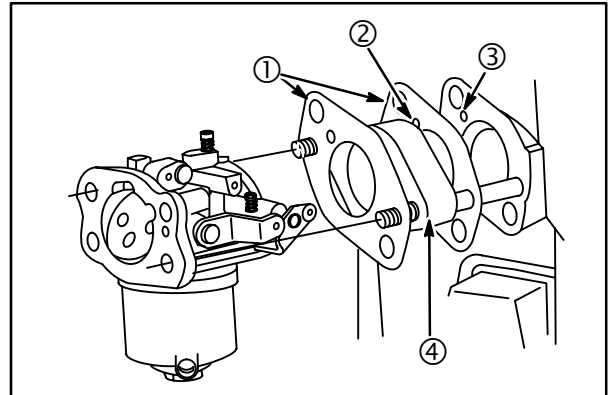


Fig. 22

#### Early style: Fig. 23

1. Insert carburetor mounting screws (5) through carburetor, gasket (1), spacer (4) and gasket (1).
2. Assemble carburetor to manifold.
  - a. Make sure that locating pin on carburetor spacer (2) fits in recess in manifold (3).
  - b. Torque screws to **65 in. lbs. (7 Nm)**.

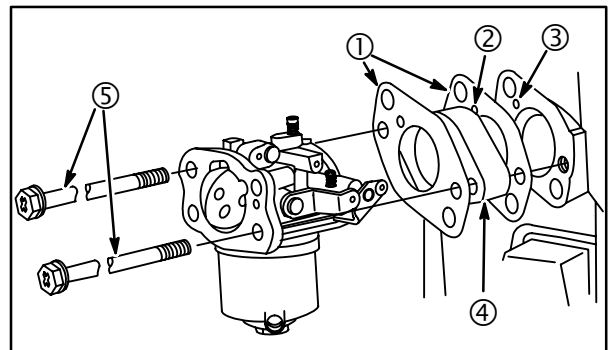
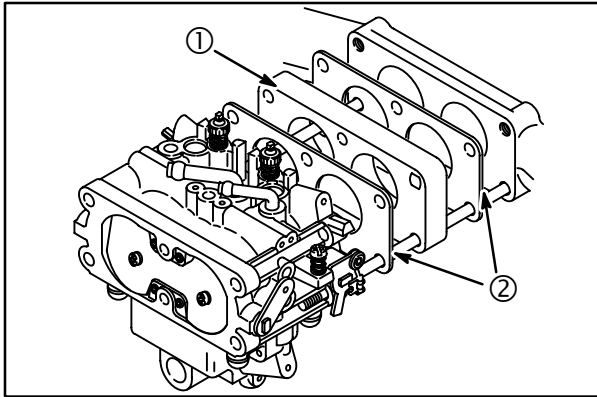


Fig. 23

Models 351700, 380700

1. Assemble gaskets (2) and spacer (1) to intake manifold.

- Assemble carburetor onto mounting studs, **Fig. 24**.

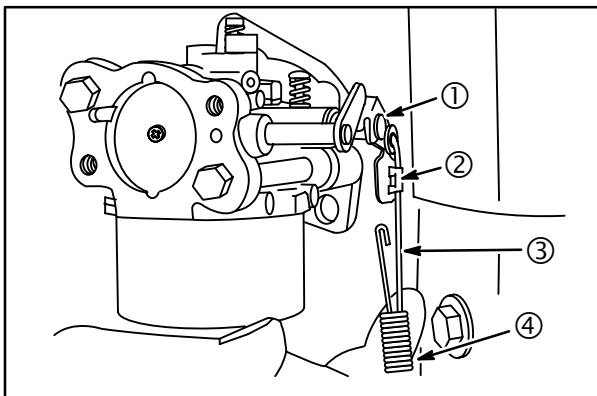


**Fig. 24**

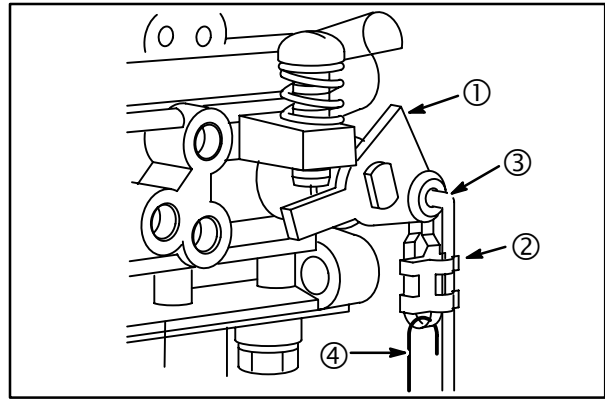
#### All Models

- Connect governor link (3) to throttle lever (1). Snap retainer (2) over link, **single barrel carburetor, Fig. 25, two barrel carburetor, Fig. 26**.
- Install governor link spring (4) in loop on retainer.

**NOTE:** If the carburetor is equipped with an anti-afterfire solenoid, route the wire under the intake manifold and through the hole in #1 cylinder shield at this time.

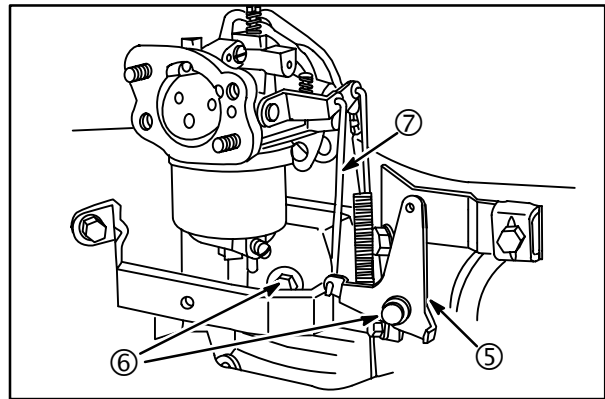


**Fig. 25**

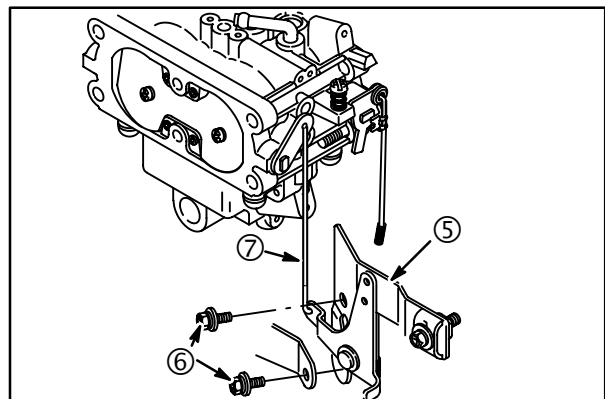


**Fig. 26**

- Connect choke link (7) to choke lever and install choke control bracket (5), **single barrel carburetor, Fig. 27, two barrel carburetor, Fig. 28**. Torque screws (6) to **65 in. lbs. (7 Nm)**.



**Fig. 27**



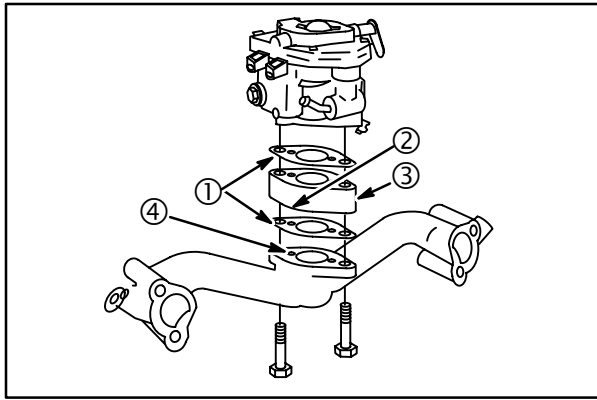
**Fig. 28**

- Install fuel line and clamp.

#### Horizontal Crankshaft

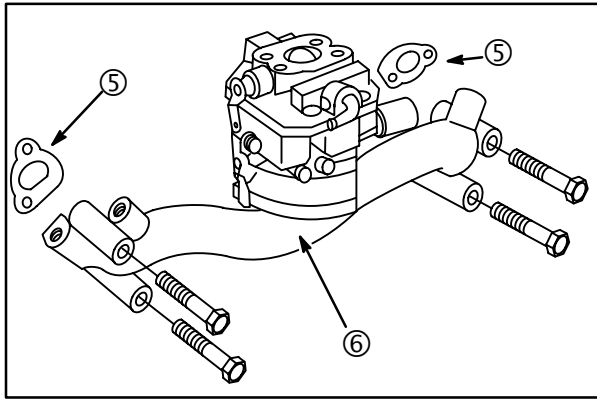
**Models 290400, 303400, 350400**

- Assemble gaskets (1), spacer (3) and carburetor to intake manifold, **Fig. 29**.



**Fig. 29**

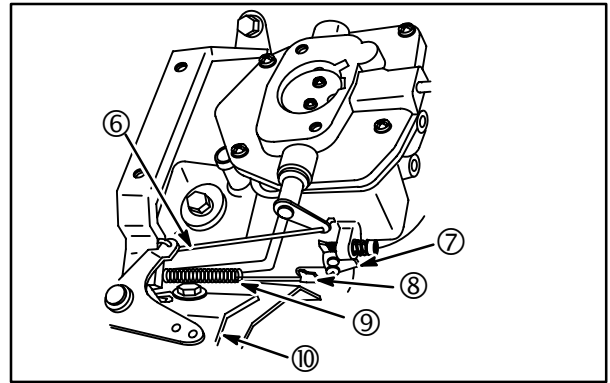
- a. Be sure locating pin (2) in spacer fits in recess (4) in manifold.
- b. Torque screws to **65 in. lbs. (7 Nm)**.
2. Install new gaskets (5) and carburetor/manifold assembly (6) to cylinder heads, **Fig. 30**. Torque screws to **140 in. lbs. (16 Nm)**.



**Fig. 30**

3. Connect governor link (9) to throttle lever (7) and snap retainer (8) over link, **Fig. 31**.
4. Install governor link spring in loop on retainer.
5. Assemble choke link (6) to carburetor and choke lever and install choke bracket (10). Torque screws to **65 in. lbs. (7 Nm)**.
6. Install fuel line and clamp. Install fuel line at carburetor. Rotate fuel line clamp tabs horizontally to prevent interference with air cleaner base.

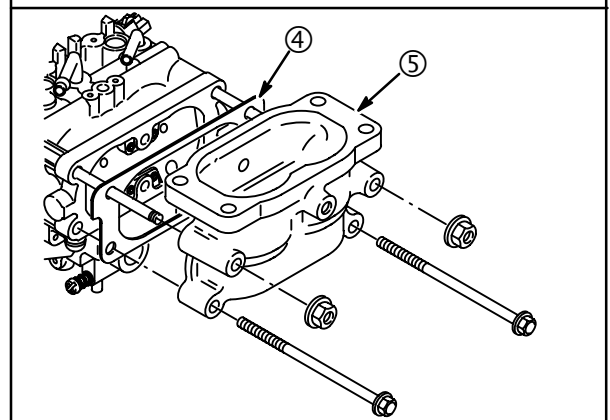
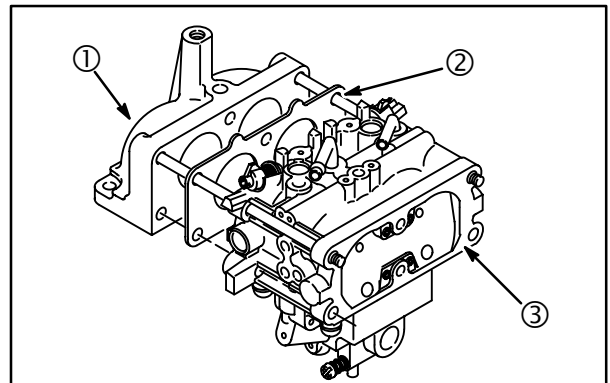
**NOTE:** If carburetor is equipped with anti-afterfire solenoid, route wire under intake manifold and through hole in #1 cylinder shield at this time.



**Fig. 31**

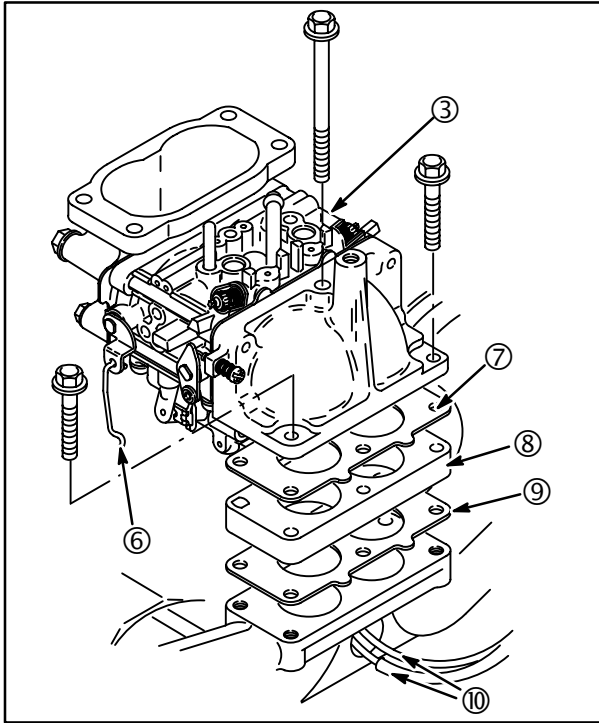
**Models 351400, 380400, 540000, 610000**

1. Assemble intake elbow (1) and air cleaner elbow (5) to carburetor (3) with new gaskets (2, 4) **Fig. 32**.
2. Install air cleaner elbow gasket (4) with adhesive side toward air cleaner elbow and arrow up.



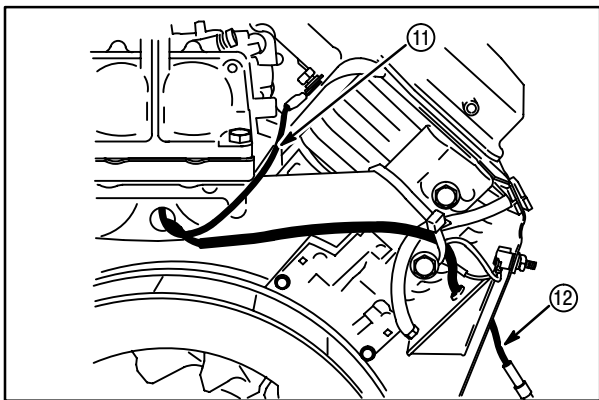
**Fig. 32**

3. Assemble choke link (6) to choke lever, **Fig. 33**.



**Fig. 33**

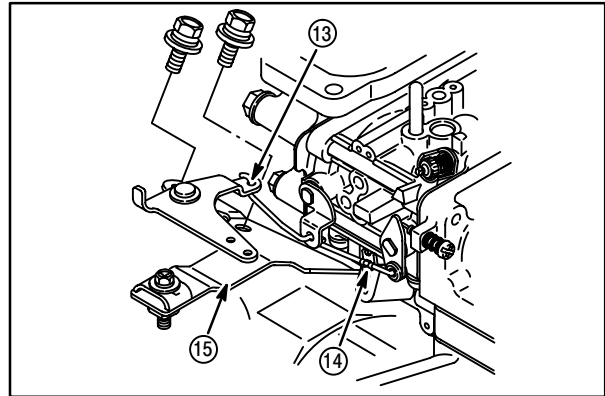
4. Assemble carburetor (3), gasket (7), spacer (8) and gasket (9) to intake manifold.
5. Route both solenoid wires (10) through hole in intake manifold. Torque three screws to **65 in. lbs. (7 Nm)**.
6. Install solenoid ground wire (11). Torque screw to **65 in. lbs. (7 Nm)**.
7. Route long solenoid wire (12) under wire tie on manifold, then through hole in #1 cylinder shield, **Fig. 34**.



**Fig. 34**

8. Connect governor link (14) to throttle lever and snap retainer over link, **Fig. 35**.
9. Install governor link spring in loop on retainer.

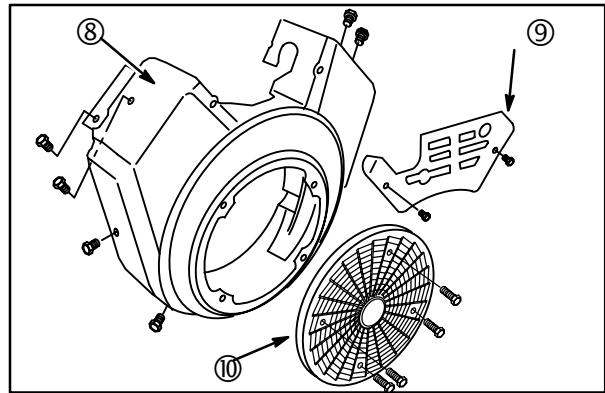
10. Assemble choke link (13) to carburetor and choke lever. Install choke bracket (15). Torque screws to **65 in. lbs. (7 Nm)**.
11. Install air cleaner elbow support. Torque screw to **65 in. lbs. (7 Nm)**.



**Fig. 35**

### Install Blower Housing

1. Install blower housing (8), **Fig. 36**.
  - a. Torque 6 mm screws to **65 in. lbs. (7 Nm)**.
  - b. Torque 8 mm screws to **140 in. lbs. (16 Nm)**.
2. Install carburetor cover (9).
3. Install rotating screen (10).



**Fig. 36**

### Install Air Cleaner

#### Vertical Crankshaft

Models 290700, 303700, 350700

**Current Style: (Round cartridge) Fig. 37.**

1. Install new air cleaner base gasket (6).
2. Guide breather tube (5) onto nipple on breather and install air cleaner base on carburetor mounting studs.
3. Install carburetor mounting nuts (2). Do not tighten nuts at this time.

4. Install breather deflector (4) and three screws (3). Torque nuts and screws to **65 in. lbs. (7 Nm)**.

Make sure air inlet tube (1) is installed correctly in air cleaner base.

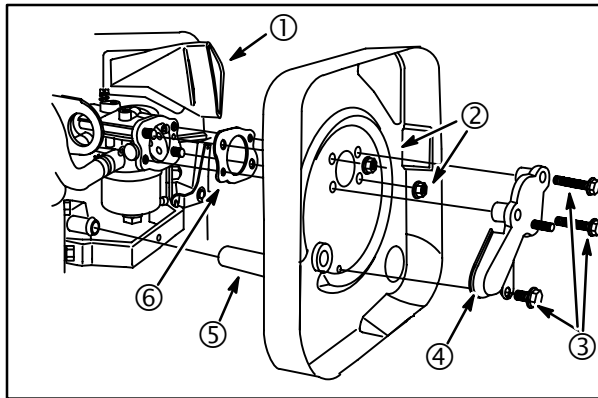


Fig. 37

**Early Style: (Square cartridge) Fig. 38.**

1. Insert mounting screws (2) through breather deflector, base (1) and gasket.
2. Guide breather tube onto breather nipple. Install mounting screws in carburetor. Do not tighten screws at this time.
3. Install two air cleaner bracket screws. Torque all four screws to **65 in. lbs. (7 Nm)**.

Make sure air inlet tube is installed correctly in air cleaner base.

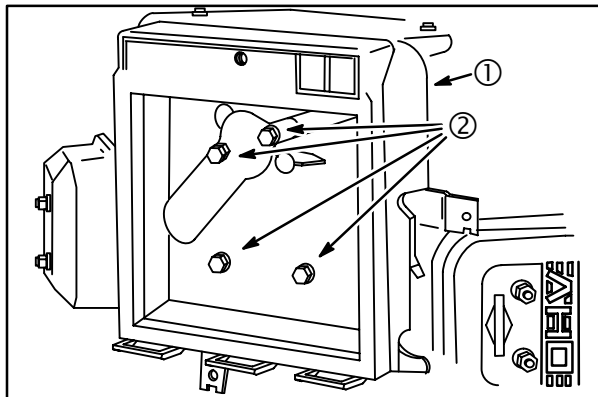


Fig. 38

**Models 351700, 380700**

1. Install new air cleaner mounting gasket with adhesive side toward air cleaner base, **Fig. 39**.
2. Guide breather tube onto breather nipple. Install air cleaner base on carburetor mounting studs.
3. Install carburetor shield (2).
4. Install nuts (3) and screws (1) finger tight.

5. Torque nuts and screws to **65 in. lbs. (7 Nm)**.

Make sure air inlet tube is installed correctly to air cleaner base.

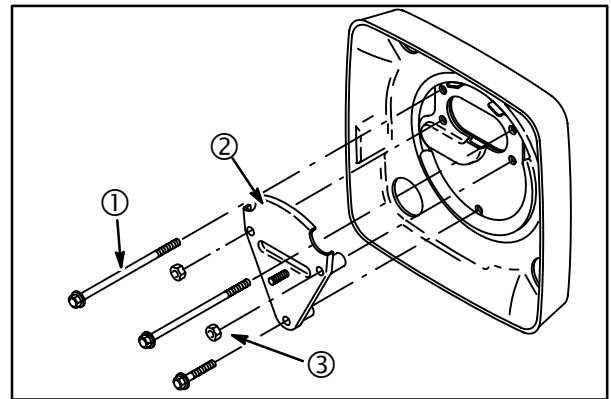


Fig. 39

**Horizontal Crankshaft  
Models 290400, 303400, 350400**

**Current Style: (Round cartridge)**

1. Install new air cleaner base gasket.
2. Guide breather tube onto breather nipple. Install air cleaner base (1) on carburetor and support bracket, **Fig. 40**.

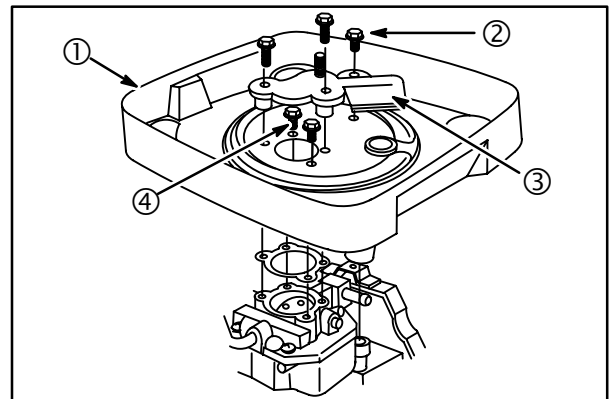


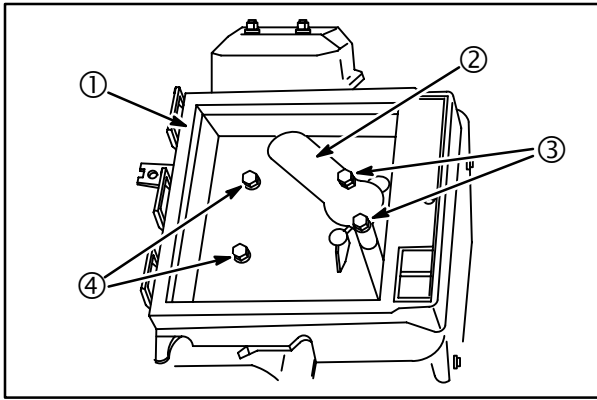
Fig. 40

3. Install two air cleaner base screws (4). Do not tighten at this time.
4. Install breather deflector (3) and three screws (2). Torque all screws to **65 in. lbs. (7 Nm)**.

Make sure air inlet tube is installed correctly in air cleaner base.

**Early Style: (Square cartridge)**

1. Install new air cleaner base gasket.
2. Guide breather tube onto nipple on breather. Install air cleaner base (1) on carburetor and support bracket, **Fig. 41**.



**Fig. 41**

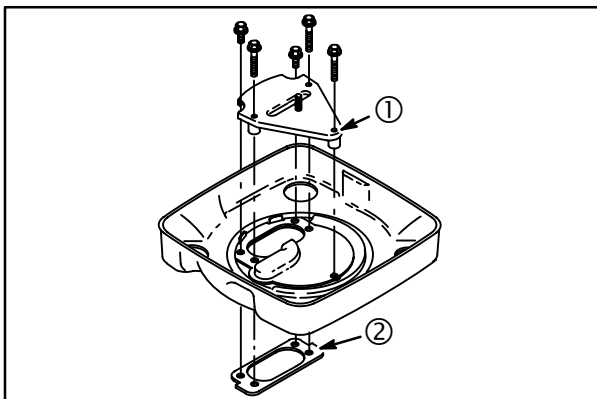
3. Install breather deflector (2) and two screws (3). Do not tighten at this time.
4. Install two air cleaner support screws (4). Torque screws to **65 in. lbs. (7 Nm)**.

Make sure air inlet tube is installed correctly in air cleaner base.

**Models 351400, 380400**

1. Install new air cleaner mounting gasket (2) with adhesive side toward air cleaner base, **Fig. 42**.
2. Connect breather tube to air cleaner base and assemble air cleaner base to air cleaner elbow.
3. Install carburetor shield (1). Install five screws finger tight. Torque screws to **65 in. lbs. (7 Nm)**.

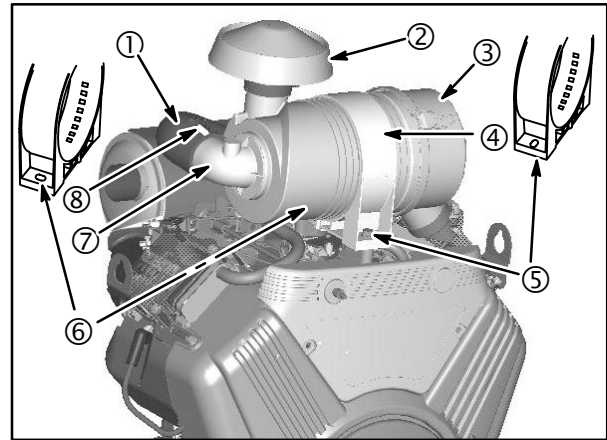
Make sure air inlet tube is installed correctly in air cleaner base.



**Fig. 42**

**Models 540000, 610000**

1. Orient the air cleaner with the air inlet (2) facing UP. Tighten the air inlet hose clamp to **30 in. lbs. (3.4 Nm)**, **Fig. 43**.



**Fig. 43**

2. With the outlet tube (7) to the LEFT, service cover (3) to the RIGHT, install the mounting band (4).

**NOTE:** The air cleaner is held in place by the mounting band. The mounting band has a **TENSIONER ADJUSTING SLOT (5)** that runs vertically and faces the front of the engine, the **SIDE ADJUSTER SLOT (6)** runs horizontally and faces the back.

3. Align the tabs on the inside of the mounting band with the slots on the outside of the air cleaner housing. Fasten the **SIDE ADJUSTER SLOT** first.
4. Push the mounting band closed and fasten the **TENSIONER ADJUSTING SLOT**. Tighten both mounting band screws to **200 in. lbs. (23 Nm)**.
5. Connect the air inlet hose (1) to the outlet tube (7). Tighten both hose clamps to **30 in. lbs. (3.4 Nm)**.

**NOTE:** The end of the air inlet hose with the white stripe connects to the outlet tube of the air cleaner. The white stripe (8) on the air inlet hose faces UP as shown.

## Final Engine Assembly



- Install muffler and exhaust manifold. Torque to **150 in. lbs. (17 Nm)**.

**NOTE:** Models **540000**, **610000** torque screws to **180 in. lbs. (20 Nm)**.

- Install spark plugs. Torque spark plugs to **180 in. lbs. (20 Nm)**.
- Install engine into equipment.
- Connect choke and throttle control cables.
- Install oil filter. Refill oil.
- Static-adjust engine governor (see below).

## Static Governor Adjustment

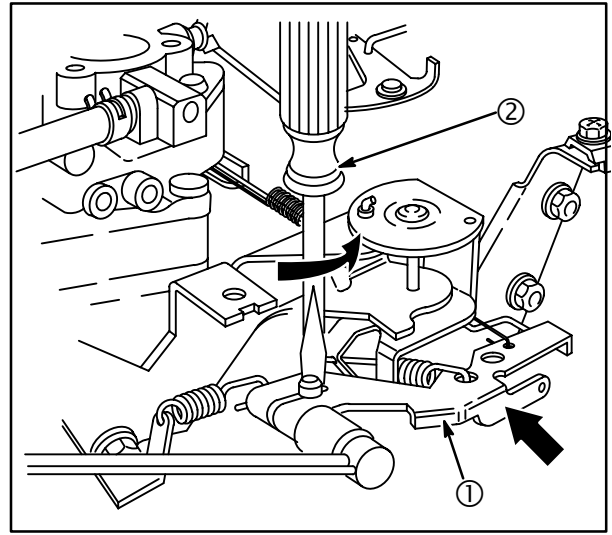
### Before Running Engine

	 <b>WARNING</b>
	<b>AVOID INJURY!</b> Complete the governor static adjustment <b>BEFORE</b> starting or running engine.
<ul style="list-style-type: none"><li>• Incorrect adjustment could result in engine overspeeding, causing engine damage, property damage or personal injury.</li><li>• Correct speed is found in the Service Engine Sales Manual Microfiche, MS-6225 or the Service Sales Manual, MS-4052.</li></ul>	

1. Loosen governor lever nut. Push on governor lever (1) until throttle is wide open.

**CAUTION:** Do not bend governor link or distort governor lever.

2. Use a screwdriver (2) to rotate governor shaft **COUNTERCLOCKWISE** as far it will go, **Fig. 44**. Torque governor nut to **70 in. lbs. (8 Nm)**.
3. Perform a dynamic governor adjustment per Section 1.



**Fig. 44**





# Section 13

## Engine Specifications

---

	Page
<b>ENGINE SPECIFICATIONS</b> .....	178
<b>Models 290000, 300000</b> .....	178
<b>Model 350000</b> .....	180
<b>Model 380000</b> .....	182
<b>Models 540000, 610000</b> .....	184
<b>Honing Fixture</b> .....	186
<b>Starter Motor Support Block</b> .....	187
<b>Starter Motor Test Bracket</b> .....	187
<b>Tables</b> .....	188
<b>Fuel System Identification</b> .....	188
<b>Carburetor Main Jets</b> .....	188
<b>Reference Pressures – Gaseous Fuel Engines</b> .....	188
<b>Diode Failure Diagnosis</b> .....	188
<b>Crankshaft Grinding Dimensions</b> .....	188
<b>Drill Size – Decimal Equivalents</b> .....	189
<b>English to Metric Conversions</b> .....	190

## Models 290000, 300000

### Common Specifications

**NOTE:** All dimensions in Inches (Millimeters)

Armature Air Gap .....	0.008 – 0.012 (0.20 – 0.30)
Crankshaft End Play .....	0.002 – 0.030 (0.05 – 0.76)
Spark Plug Gap .....	0.030 (0.76)
Valve Clearance – Measured Cold	
Intake .....	0.004 – 0.006 (0.10 – 0.15)
Exhaust .....	0.004 – 0.006 (0.10 – 0.15)

### Dimensional Specifications

**NOTE:** All dimensions in Inches (Millimeters)

<i>Description</i>	<i>Standard Dimension</i>	<i>Reject Dimension</i>
<b>Cylinder</b>		
Bore		
Models 290000 & 303000 .....	2.677 – 2.678 (68.00 – 68.03)	2.681 (68.10)
Out-of-round .....		0.002 (0.05)
Main Bearing		
Before 970501100 .....	1.182 – 1.183 (30.03 – 30.06)	1.184 (30.08)
After 97043000 .....	1.379 – 1.380 (35.02 – 35.06)	1.383 (35.12)
Cam Bearing .....	0.630 – 0.631 (16.00 – 16.03)	0.633 (16.08)
<b>Cylinder Head</b>		
Valve Guide .....	0.2366 – 0.237 (6.01 – 6.02)	0.238 (6.05)
Valve Stem–		
Intake .....	0.234 – 0.235 (5.95 – 5.96)	0.233 (5.92)
Exhaust .....	0.2338 – 0.234 (5.94 – 5.95)	0.2327 (5.91)
<b>Crankcase Cover</b>		
Main Bearing .....	1.3795 – 1.380 (35.04 – 35.05)	1.381 (35.07)
Cam Bearing .....	0.7874 – 0.788 (20.0 – 20.02)	0.789 (20.04)
<b>Crankshaft</b>		
Crankpin .....	1.4567 – 1.458 (37.00 – 37.03)	1.455 (36.95)
Magneto Journal		
Before 9705010 .....	1.180 – 1.181 (29.98 – 30.00)	1.179 (29.94)
After 97043000 .....	1.376 – 1.378 (34.95 – 35.00)	1.376 (34.95)
PTO Journal .....	1.376 – 1.377 (34.95 – 34.98)	1.375 (34.92)
Throw .....	1.444 – 1.447 (36.66 – 36.74)	
<b>Camshaft</b>		
Magneto Journal .....	0.628 – 0.629 (15.95 – 15.97)	0.627 (15.93)
PTO Journal .....	0.785 – 0.7854 (19.94 – 19.95)	0.7843 (19.92)
Lobes		
Intake .....	1.194 – 1.202 (30.33 – 30.53)	1.191 (30.25)
Exhaust .....	1.194 – 1.202 (30.33 – 30.53)	1.191 (30.25)
<b>Connecting Rod</b>		
Crankpin Bearing .....	1.459 – 1.460 (37.06 – 37.08)	1.461 (37.12)
Piston Pin Bearing .....	0.6728 – 0.6732 (17.09 – 17.10)	0.674 (17.12)
<b>Piston Pin</b> .....	0.6720 – 0.6724 (17.07 – 17.08)	0.6717 (17.06)
<b>Piston Pin Bearing (Piston)</b> .....	0.6728 – 0.6732 (17.09 – 17.10)	0.674 (17.12)
<b>Piston Rings</b>		
End Gap – Top, Center & Oil .....	0.008 – 0.016 (0.20 – 0.40)	0.030 (0.76)
Side Clearance		
Top & Center Rings .....	0.002 – 0.003 (0.05 – 0.08)	0.004 (0.10)
Oil Control Rings .....	0.0045 – 0.006 (0.11 – 0.15)	0.008 (0.20)

## Torque Values

<i><b>Description</b></i>	<i><b>Torque</b></i>
Air Cleaner Mounting .....	90 in. lbs. (10 Nm)
Air Guide Mounting Screws .....	90 in. lbs. (10 Nm)
Air Block Plate Mounting Screws .....	30 in. lbs. (3 Nm)
Alternator .....	20 in. lbs. (2 Nm)
Alternator Harness Clamp Screw .....	90 in. lbs. (10 Nm)
Air Cleaner Base (to carburetor) .....	65 in. lbs. (7 Nm)
Air Cleaner Support Bracket .....	65 in. lbs. (7 Nm)
Armature .....	25 in. lbs. (3 Nm)
Back Plate .....	65 in. lbs. (7 Nm)
Blower Housing .....	65 in. lbs. (7 Nm)
Breather .....	30 in. lbs. (3 Nm)
Carburetor to Manifold .....	65 in. lbs. (7 Nm)
Connecting Rod .....	115 in. lbs. (13 Nm)
Crankcase Cover .....	150 in. lbs. (17 Nm)
Cylinder Head .....	165 in. lbs. (19 Nm)
Cylinder Shield .....	65 in. lbs. (7 Nm)
Exhaust Manifold .....	150 in. lbs. (17 Nm)
Fan Retainer .....	150 in. lbs. (17 Nm)
Flywheel .....	125 ft. lbs. (170 Nm)
Fuel Pump .....	45 in. lbs. (5 Nm)
Governor Control Bracket .....	140 in. lbs. (16 Nm)
Governor Lever Nut .....	70 in. lbs. (8 Nm)
Intake Manifold .....	140 in. lbs. (16 Nm)
Oil Pump .....	65 in. lbs. (7 Nm)
Rewind Starter (to blower housing) .....	65 in. lbs. (7 Nm)
Rocker Arm Lock Nut .....	70 in. lbs. (8 Nm)
Rocker Arm Stud	
– Current Style .....	100 in. lbs. (11 Nm)
– Early Style .....	140 in. lbs. (16 Nm)
Spark Plug .....	180 in. lbs. (20 Nm)
Starter Motor .....	140 in. lbs. (16 Nm)
Valve Cover .....	70 in. lbs. (8 Nm)

## Model 350000

### Common Specifications

**NOTE:** All dimensions in Inches (Millimeters)

Armature Air Gap .....	0.008 – 0.012 (0.20 – 0.30)
Crankshaft End Play .....	0.002 – 0.030 (0.05 – 0.76)
Spark Plug Gap .....	0.030 (0.76)
Valve Clearance – Measured Cold	
Intake .....	0.004 – 0.006 (0.10 – 0.15)
Exhaust .....	0.004 – 0.006 (0.10 – 0.15)

### Dimensional Specifications

**NOTE:** All dimensions in Inches (Millimeters)

<i>Description</i>	<i>Standard Dimension</i>	<i>Reject Dimension</i>
<b>Cylinder</b>		
Bore .....	2.835 – 2.836 (72.00 – 72.03)	2.841 (72.16)
Out-of-round .....		0.002 (0.05)
Main Bearing		
Before 970501100 .....	1.182 – 1.183 (30.03 – 30.06)	1.184 (30.08)
After 97043000 .....	1.379 – 1.380 (35.02 – 35.06)	1.383 (35.12)
Cam Bearing .....	0.630 – 0.631 (16.00 – 16.03)	0.633 (16.08)
<b>Cylinder Head</b>		
Valve Guide .....	0.2366 – 0.237 (6.01 – 6.02)	0.238 (6.05)
Valve Stem–		
Intake .....	0.234 – 0.235 (5.95 – 5.96)	0.233 (5.92)
Exhaust .....	0.2338 – 0.234 (5.94 – 5.95)	0.2327 (5.91)
<b>Crankcase Cover</b>		
Main Bearing .....	1.3795 – 1.380 (35.04 – 35.05)	1.381 (35.07)
Cam Bearing .....	0.7874 – 0.788 (20.0 – 20.02)	0.789 (20.04)
<b>Crankshaft</b>		
Crankpin .....	1.4567 – 1.458 (37.00 – 37.03)	1.455 (36.95)
Magneto Journal		
Before 9705010 .....	1.180 – 1.181 (29.98 – 30.00)	1.179 (29.94)
After 97043000 .....	1.376 – 1.378 (34.95 – 35.00)	1.376 (34.95)
PTO Journal .....	1.376 – 1.377 (34.95 – 34.98)	1.375 (34.92)
Throw .....	1.444 – 1.447 (36.66 – 36.74)	
<b>Camshaft</b>		
Magneto Journal .....	0.628 – 0.629 (15.95 – 15.97)	0.627 (15.93)
PTO Journal .....	0.785 – 0.7854 (19.94 – 19.95)	0.7843 (19.92)
Lobes		
Intake .....	1.194 – 1.202 (30.33 – 30.53)	1.191 (30.25)
Exhaust .....	1.194 – 1.202 (30.33 – 30.53)	1.191 (30.25)
<b>Connecting Rod</b>		
Crankpin Bearing .....	1.459 – 1.460 (37.06 – 37.08)	1.461 (37.12)
Piston Pin Bearing .....	0.6728 – 0.6732 (17.09 – 17.10)	0.674 (17.12)
<b>Piston Pin</b> .....	0.6720 – 0.6724 (17.07 – 17.08)	0.6717 (17.06)
<b>Piston Pin Bearing (Piston)</b> .....	0.6728 – 0.6732 (17.09 – 17.10)	0.674 (17.12)
<b>Piston Rings</b>		
End Gap – Top, Center & Oil .....	0.008 – 0.016 (0.20 – 0.40)	0.030 (0.76)
Side Clearance		
Top & Center Rings .....	0.002 – 0.003 (0.05 – 0.08)	0.004 (0.10)
Oil Control Rings .....	0.0045 – 0.006 (0.11 – 0.15)	0.008 (0.20)

## Torque Values

<i><b>Description</b></i>	<i><b>Torque</b></i>
Air Cleaner Mounting .....	90 in. lbs. (10 Nm)
Air Guide Mounting Screws .....	90 in. lbs. (10 Nm)
Air Block Plate Mounting Screws .....	30 in. lbs. (3 Nm)
Alternator .....	20 in. lbs. (2 Nm)
Alternator Harness Clamp Screw .....	90 in. lbs. (10 Nm)
Air Cleaner Base (to carburetor) .....	65 in. lbs. (7 Nm)
Air Cleaner Support Bracket .....	65 in. lbs. (7 Nm)
Armature .....	25 in. lbs. (3 Nm)
Back Plate .....	65 in. lbs. (7 Nm)
Blower Housing .....	65 in. lbs. (7 Nm)
Breather .....	30 in. lbs. (3 Nm)
Carburetor to Manifold .....	65 in. lbs. (7 Nm)
Connecting Rod .....	115 in. lbs. (13 Nm)
Crankcase Cover .....	150 in. lbs. (17 Nm)
Cylinder Head .....	165 in. lbs. (19 Nm)
Cylinder Shield .....	65 in. lbs. (7 Nm)
Exhaust Manifold .....	150 in. lbs. (17 Nm)
Fan Retainer .....	150 in. lbs. (17 Nm)
Flywheel .....	125 ft. lbs. (170 Nm)
Fuel Pump .....	45 in. lbs. (5 Nm)
Governor Control Bracket .....	140 in. lbs. (16 Nm)
Governor Lever Nut .....	70 in. lbs. (8 Nm)
Intake Manifold .....	140 in. lbs. (16 Nm)
Oil Pump .....	65 in. lbs. (7 Nm)
Rewind Starter (to blower housing) .....	65 in. lbs. (7 Nm)
Rocker Arm Lock Nut .....	70 in. lbs. (8 Nm)
Rocker Arm Stud	
– Current Style .....	100 in. lbs. (11 Nm)
– Early Style .....	140 in. lbs. (16 Nm)
Spark Plug .....	180 in. lbs. (20 Nm)
Starter Motor .....	140 in. lbs. (16 Nm)
Valve Cover .....	70 in. lbs. (8 Nm)

## Model 380000

### Common Specifications

**NOTE:** All dimensions in Inches (Millimeters)

Armature Air Gap .....	0.008 – 0.012 (0.20 – 0.30)
Crankshaft End Play .....	0.002 – 0.030 (0.05 – 0.76)
Spark Plug Gap .....	0.030 (0.76)
Valve Clearance – Measured Cold	
Intake .....	0.004 – 0.006 (0.10 – 0.15)
Exhaust .....	0.004 – 0.006 (0.10 – 0.15)

### Dimensional Specifications

**NOTE:** All dimensions in Inches (Millimeters)

<i>Description</i>	<i>Standard Dimension</i>	<i>Reject Dimension</i>
<b>Cylinder</b>		
Bore .....	2.972 – 2.973 (75.50 – 75.52)	2.976 (75.59)
Out-of-round .....		0.002 (0.05)
Main Bearing		
Before 970501100 .....	1.182 – 1.183 (30.03 – 30.06)	1.184 (30.08)
After 97043000 .....	1.379 – 1.380 (35.02 – 35.06)	1.383 (35.12)
Cam Bearing .....	0.630 – 0.631 (16.00 – 16.03)	0.633 (16.08)
<b>Cylinder Head</b>		
Valve Guide .....	0.2366 – 0.237 (6.01 – 6.02)	0.238 (6.05)
Valve Stem–		
Intake .....	0.234 – 0.235 (5.95 – 5.96)	0.233 (5.92)
Exhaust .....	0.2338 – 0.234 (5.94 – 5.95)	0.2327 (5.91)
<b>Crankcase Cover</b>		
Main Bearing .....	1.3795 – 1.380 (35.04 – 35.05)	1.381 (35.07)
Cam Bearing .....	0.7874 – 0.788 (20.0 – 20.02)	0.789 (20.04)
<b>Crankshaft</b>		
Crankpin .....	1.4567 – 1.458 (37.00 – 37.03)	1.455 (36.95)
Magneto Journal		
Before 9705010 .....	1.180 – 1.181 (29.98 – 30.00)	1.179 (29.94)
After 97043000 .....	1.376 – 1.378 (34.95 – 35.00)	1.376 (34.95)
PTO Journal .....	1.376 – 1.377 (34.95 – 34.98)	1.375 (34.92)
Throw .....	1.444 – 1.447 (36.66 – 36.74)	
<b>Camshaft</b>		
Magneto Journal .....	0.628 – 0.629 (15.95 – 15.97)	0.627 (15.93)
PTO Journal .....	0.785 – 0.7854 (19.94 – 19.95)	0.7843 (19.92)
Lobes		
Intake .....	1.224 – 1.232 (31.09 – 31.30)	1.223 (31.06)
Exhaust .....	1.194 – 1.202 (30.33 – 30.53)	1.191 (30.25)
<b>Connecting Rod</b>		
Crankpin Bearing .....	1.459 – 1.460 (37.06 – 37.08)	1.461 (37.12)
Piston Pin Bearing .....	0.710 – 0.711 (18.03 – 18.06)	0.711 (18.06)
<b>Piston Pin</b> .....	0.7087 – 0.709 (18.00 – 18.01)	0.7079 (17.98)
<b>Piston Pin Bearing (Piston)</b> .....	0.710 – 0.711 (18.04 – 18.05)	0.711 (18.06)
<b>Piston Rings</b>		
End Gap – Top, Center & Oil .....	0.008 – 0.016 (0.20 – 0.40)	0.030 (0.76)
Side Clearance		
Top & Center Rings .....	0.002 – 0.003 (0.05 – 0.08)	0.004 (0.10)
Oil Control Rings .....	0.0045 – 0.006 (0.11 – 0.15)	0.008 (0.20)

## Torque Values

<i><b>Description</b></i>	<i><b>Torque</b></i>
Air Cleaner Mounting .....	90 in. lbs. (10 Nm)
Air Guide Mounting Screws .....	90 in. lbs. (10 Nm)
Air Block Plate Mounting Screws .....	30 in. lbs. (3 Nm)
Alternator .....	20 in. lbs. (2 Nm)
Alternator Harness Clamp Screw .....	90 in. lbs. (10 Nm)
Air Cleaner Base (to carburetor) .....	65 in. lbs. (7 Nm)
Air Cleaner Support Bracket .....	65 in. lbs. (7 Nm)
Armature .....	25 in. lbs. (3 Nm)
Back Plate .....	65 in. lbs. (7 Nm)
Blower Housing .....	65 in. lbs. (7 Nm)
Breather .....	30 in. lbs. (3 Nm)
Carburetor to Manifold .....	65 in. lbs. (7 Nm)
Connecting Rod .....	115 in. lbs. (13 Nm)
Crankcase Cover .....	150 in. lbs. (17 Nm)
Cylinder Head .....	165 in. lbs. (19 Nm)
Cylinder Shield .....	65 in. lbs. (7 Nm)
Exhaust Manifold .....	150 in. lbs. (17 Nm)
Fan Retainer .....	150 in. lbs. (17 Nm)
Flywheel .....	125 ft. lbs. (170 Nm)
Fuel Pump .....	45 in. lbs. (5 Nm)
Governor Control Bracket .....	140 in. lbs. (16 Nm)
Governor Lever Nut .....	70 in. lbs. (8 Nm)
Intake Manifold .....	140 in. lbs. (16 Nm)
Oil Pump .....	65 in. lbs. (7 Nm)
Rewind Starter (to blower housing) .....	65 in. lbs. (7 Nm)
Rocker Arm Lock Nut .....	70 in. lbs. (8 Nm)
Rocker Arm Stud	
– Current Style .....	100 in. lbs. (11 Nm)
– Early Style .....	140 in. lbs. (16 Nm)
Spark Plug .....	180 in. lbs. (20 Nm)
Starter Motor .....	140 in. lbs. (16 Nm)
Valve Cover .....	70 in. lbs. (8 Nm)



## Models 540000, 610000

### Common Specifications

**NOTE:** All dimensions in Inches (Millimeters)

Armature Air Gap .....	0.005 – 0.007 (0.13 – 0.18)
Crankshaft End Play .....	0.002 – 0.012 (0.05 – 0.30)
Spark Plug Gap .....	0.020 (0.51)
Valve Clearance – Measured Cold	
Intake .....	0.004 – 0.006 (0.10 – 0.15)
Exhaust .....	0.004 – 0.006 (0.10 – 0.15)

### Dimensional Specifications

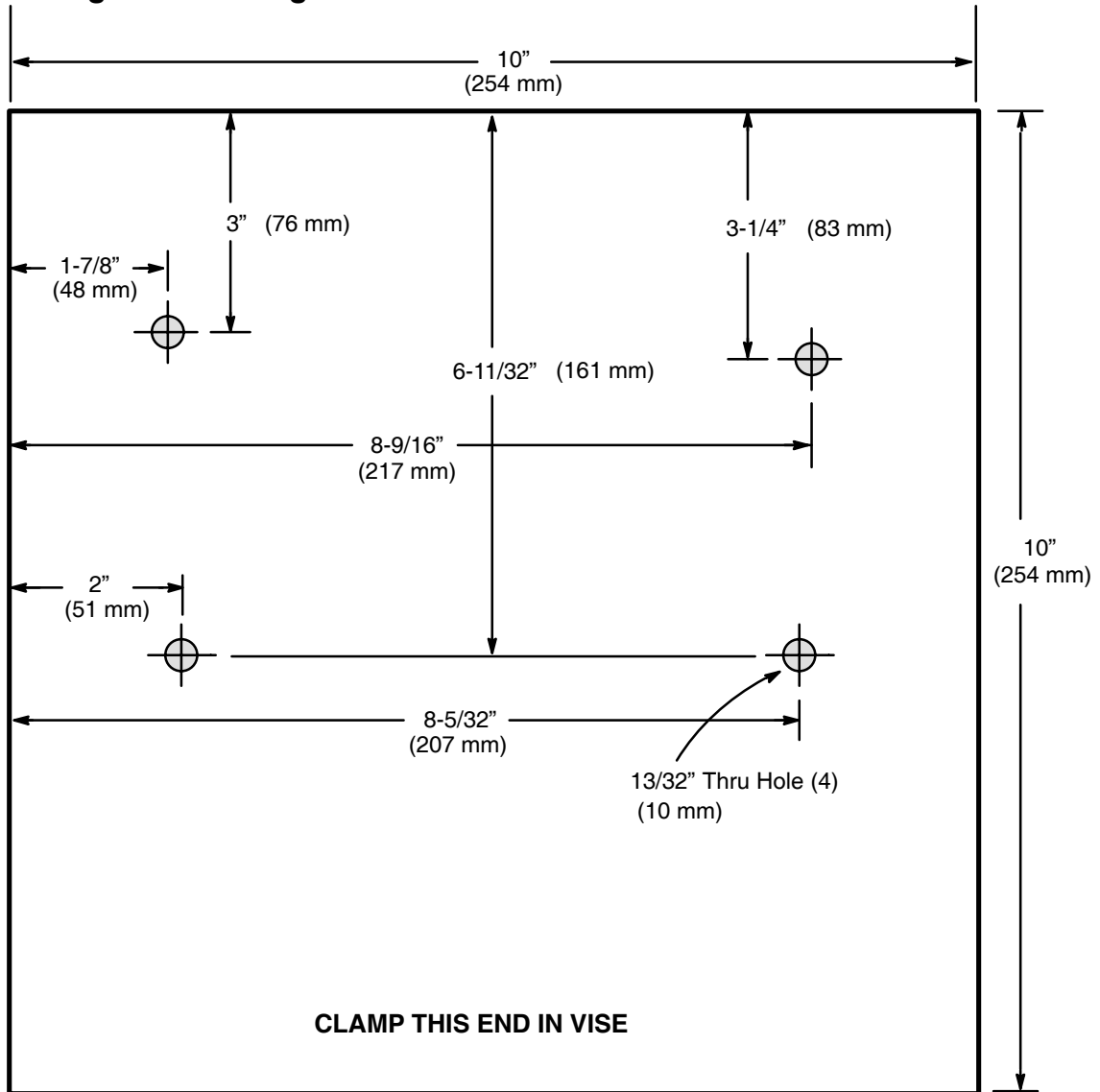
**NOTE:** All dimensions in Inches (Millimeters)

<i>Description</i>	<i>Standard Dimension</i>	<i>Reject Dimension</i>
<b>Cylinder</b>		
Bore .....	3.366 (85.50) .....	3.369 (85.57)
Out-of-round .....		0.002 (0.05)
Main Bearing .....	1.775 (45.09) .....	1.777 (45.12)
Cam Bearing .....	0.630 – 0.631 (16.00 – 16.03) .....	0.633 (16.08)
<b>Cylinder Head</b>		
Valve Guide .....	0.2366 – 0.237 (6.01 – 6.02) .....	0.238 (6.05)
Valve Stem–		
Intake .....	0.234 – 0.235 (5.95 – 5.96) .....	0.233 (5.92)
Exhaust .....	0.2338 – 0.234 (5.94 – 5.95) .....	0.2327 (5.91)
<b>Crankcase Cover</b>		
Main Bearing .....	1.3795 – 1.380 (35.04 – 35.05) .....	1.381 (35.07)
Cam Bearing .....	0.7874 – 0.788 (20.0 – 20.02) .....	0.789 (20.04)
<b>Crankshaft</b>		
Crankpin .....	1.654 (42.01) .....	1.6525 (41.97)
Magneto Journal .....	1.771 (44.98) .....	1.7695 (44.95)
PTO Journal .....	1.771 (44.98) .....	1.7695 (44.95)
<b>Camshaft</b>		
Magneto Journal .....	0.786 (19.96) .....	0.7485 (19.93)
PTO Journal .....	0.786 (19.96) .....	0.7485 (19.93)
<b>Connecting Rod</b>		
Crankpin Bearing .....	1.656 (42.06) .....	1.658 (42.11)
Piston Pin Bearing .....	0.827 (21.01) .....	0.828 (21.03)
<b>Piston Pin</b> .....	0.8268 (21.00) .....	0.8258 (20.98)
<b>Piston Pin Bearing (Piston)</b> .....	0.827 (21.01) .....	0.828 (21.03)
<b>Piston Rings</b>		
End Gap		
Top .....	0.007 – 0.013 (0.20 – 0.35) .....	0.030 (0.76)
Center .....	0.013 – 0.021 (0.35 – 0.55) .....	0.030 (0.76)
Oil .....	0.007 – 0.057 (0.20 – 0.70) .....	0.040 (1.00)
Side Clearance		
Top .....	0.003 (0.07) .....	0.006 (0.15)
Center .....	0.002 (0.05) .....	0.004 (0.10)
Oil .....	0.0015 (0.04) .....	0.008 (0.20)

## Torque Values

<i>Description</i>	<i>Torque</i>
Air Cleaner Mounting	190 in. lbs. (21 Nm)
Air Guide Mounting Screws	90 in. lbs. (10 Nm)
Air Block Plate Mounting Screws	90 in. lbs. (10 Nm)
Alternator	35 in. lbs. (4 Nm)
Alternator Harness Clamp Screw	90 in. lbs. (10 Nm)
Air Cleaner Base (to carburetor)	65 in. lbs. (7 Nm)
Air Cleaner Support Bracket	65 in. lbs. (7 Nm)
Armature	35 in. lbs. (4 Nm)
Back Plate	90 in. lbs. (10 Nm)
Blower Housing	90 in. lbs. (10 Nm)
Breather	45 in. lbs. (5 Nm)
Carburetor to Manifold	90 in. lbs. (10 Nm)
Carburetor Intake Elbow to Carburetor	90 in. lbs. (10 Nm)
Connecting Rod	125 in. lbs. (14 Nm)
Crankcase Cover	200 in. lbs. (23 Nm)
Cylinder Head	350 in. lbs. (40 Nm)
Cylinder Shield	90 in. lbs. (10 Nm)
Exhaust Manifold	200 in. lbs. (23 Nm)
Flywheel	150 ft. lbs. (203 Nm)
Flywheel Fan Screws	90 in. lbs. (10 Nm)
Fuel Pump	45 in. lbs. (5 Nm)
Governor Control Bracket	200 in. lbs. (23 Nm)
Governor Lever Nut	70 in. lbs. (8 Nm)
Ignition Armature	30 in. lbs. (3 Nm)
Intake Manifold	180 in. lbs. (20 Nm)
Oil Drain Plug	180 in. lbs. (20 Nm)
Oil Pickup to Pump	90 in. lbs. (10 Nm)
Oil Pressure Switch	80 in. lbs. (9 Nm)
Oil Pump to Crankcase Cover	90 in. lbs. (10 Nm)
Regulator Rectifier	90 in. lbs. (10 Nm)
Rocker Arm Lock Nut	70 in. lbs. (8 Nm)
Rocker Arm Stud	100 in. lbs. (11 Nm)
Rotating Screen Screws	100 in. lbs. (11 Nm)
Rotating Screen Studs	125 in. lbs. (14 Nm)
Spark Plug	180 in. lbs. (20 Nm)
Starter Motor	140 in. lbs. (16 Nm)
Valve Cover	70 in. lbs. (8 Nm)

# Vanguard™ Engines – Honing Fixture



**Material: Wood 2" x 10" x 10" (51 mm x 254 mm x 254 mm)**

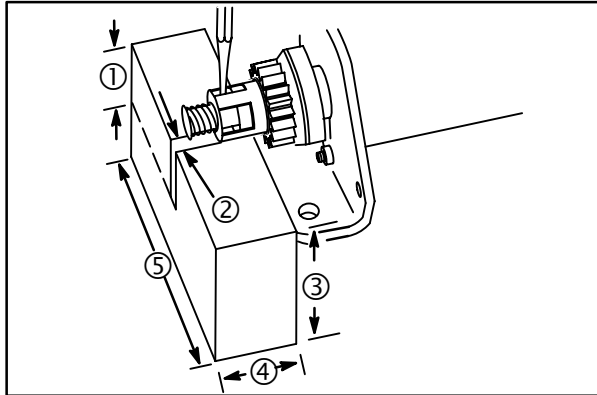
**Cylinder Mounting Hardware Fasteners Required:**

**4 @ Crankcase Cover Screws, 4 @ Flat Washers 3/8" (9.5 mm) I.D.**

## Starter Motor Support Block

A starter motor support block can be made from stock 1" (25.4 mm) thick as shown in **Fig. 1**. The dimensions for the block are:

1. 1" (25.4 mm)
2. 0.4" (10.2 mm)
3. 2" (51 mm)
4. 1" (25 mm)
5. 5" (127 mm)



**Fig. 1**

## Starter Motor Test Bracket

A starter motor test bracket may be made from metal stock 1/4" (6.4 mm) thick steel as shown in **Fig. 2**. The dimensions for the test bracket are:

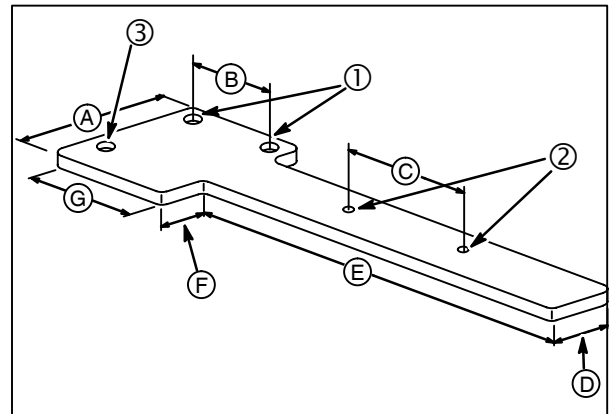
- a. 4" (101.6 mm)
- b. 2-1/4" (57.2 mm)
- c. 3-1/2" (88.9 mm)

- d. 2" (50.8 mm)
- e. 10" (254 mm)
- f. 1" (25.4 mm)
- g. 3-1/2" (88.9 mm)

1. Drill two holes (1) 3/8" (9.5 mm) diameter for mounting starter.
2. Use a #7 drill to drill two holes (2) to mount Tachometer #19200. Tap holes for 1/4-20 screws.
3. Drill an extra hole (3) for mounting starter brackets.

• **CAUTION:** DO NOT clamp motor housing in a vise or strike with a hammer. Starter motors contain ceramic magnets that could be broken or cracked if the housing is damaged.

A growler or armature tester is available from an automotive parts supplier.



**Fig. 2**

FUEL SYSTEM IDENTIFICATION		
Model	Fuel System Type	Color Code
290400	Gravity	Yellow
290400	Pump	White
294400	Gravity	Pump
294400	Pump	None
303400	Gravity	Blue
303400	Pump	None
350400	Gravity	Blue
350400	Pump	None

CARBURETOR MAIN JETS	
Model	Jet Number
351400	Left cylinder (#1) #94 Right cylinder (#2) #98
351700	Left cylinder (#1) #98 Right cylinder (#2) #100
380400	Left cylinder (#1) #110 Right cylinder (#2) #114
380700	Left cylinder (#1) #118 Right cylinder (#2) #116
405770	#132
445770	#140
540000 610000	Left Cylinder #136 Right Cylinder #138 Secondary Upper #120 (2 used) Secondary Lower #150 (2 used)

REFERENCE PRESSURES FOR GASEOUS FUELED ENGINES	
Tank Pressure	90 psi minimum
Secondary inlet under load	11 inches of water
Secondary outlet under load	0 to slight vacuum
1 psi = 16 ounces = 27.72 inches of water	

DIODE FAILURE DIAGNOSIS		
Switch ON	Switch OFF	Cause
Engine Runs on Only 1 Cylinder	Shuts Off OK	1 Closed Diode
Engine Runs on Both Cylinders	Only 1 Cylinder Shuts Off	1 Open Diode
Won't Run (No Spark)		2 Closed Diodes
Engine Runs on Both Cylinders	Engine Won't Shut Off	2 Open Diodes

CRANKSHAFT GRINDING DIMENSIONS			
NOTE: Dimensions in Inches (Millimeters), Fig. 3			
Model	Crankpin Diameter (Dim. A)	Throw (Dim. T)	Fillet Radius (Dim. R)
29/30	1.4567 – 1.4568	1.30 (33.02)	0.170 – 0.180 (4.32 – 4.57)
350/351	(37.00)	1.375 (34.93)	
38	37.03)		
54	1.654 (42.01)	1.535 (39.00)	
61	1.654 (42.01)		

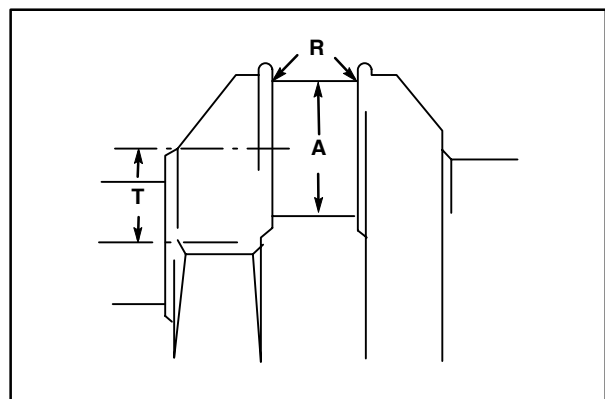


Fig. 3

## Drill Size – Decimal Equivalent (Inches)

60 — 0.040	9/64 — 0.1406	E, 1/4 — 0.250
59 — 0.041	27 — 0.144	F — 0.257
58 — 0.042	26 — 0.147	G — 0.261
57 — 0.043	25 — 0.1495	17/64 — 0.2656
56 — 0.0465	24 — 0.152	H — 0.266
55 — 0.052	23 — 0.154	I — 0.272
54 — 0.055	5/32 — 0.1562	J — 0.277
53 — 0.0595	22 — 0.157	K — 0.281
1/16 — 0.0625	21 — 0.159	9/32 — 0.2812
52 — 0.0635	20 — 0.161	L — 0.290
51 — 0.067	19 — 0.166	M — 0.295
50 — 0.070	18 — 0.1695	19/64 — 0.2969
49 — 0.073	11/64 — 0.1719	N — 0.302
48 — 0.076	17 — 0.173	5/16 — 0.3125
5/64 — 0.0781	16 — 0.177	O — 0.316
47 — 0.0785	15 — 0.180	P — 0.323
46 — 0.081	14 — 0.182	21/64 — 0.3281
45 — 0.082	13 — 0.185	Q — 0.332
44 — 0.086	3/16 — 0.1875	R — 0.339
43 — 0.089	12 — 0.189	11/32 — 0.3438
42 — 0.0935	11 — 0.191	S — 0.348
3/32 — 0.0938	10 — 0.1935	T — 0.358
41 — 0.096	9 — 0.196	23/64 — 0.3594
40 — 0.098	8 — 0.199	U — 0.368
39 — 0.0995	7 — 0.201	3/8 — 0.375
38 — 0.1015	13/64 — 0.2031	V — 0.377
37 — 0.104	6 — 0.204	W — 0.386
36 — 0.1065	5 — 0.2055	25/64 — 0.3906
7/64 — 0.1094	4 — 0.209	X — 0.397
35 — 0.110	3 — 0.213	Y — 0.404
34 — 0.111	7/32 — 0.2188	13/32 — 0.4062
33 — 0.113	2 — 0.221	Z — 0.413
32 — 0.116	1 — 0.228	27/64 — 0.4219
31 — 0.120	A — 0.234	7/16 — 0.4375
1/8 — 0.125	15/64 — 0.2344	29/64 — 0.4531
30 — 0.1285	B — 0.238	15/32 — 0.4688
29 — 0.136	C — 0.242	31/64 — 0.4844
28 — 0.1405	D — 0.246	1/2 — 0.500

## English to Metric Conversion Table

Fraction	Decimal	mm	Fraction	Decimal	mm
1/64	0.0156	0.396	33/64	0.5156	13.096
1/32	0.0313	0.795	17/32	0.5313	13.495
3/64	0.0469	1.191	35/64	0.5469	13.891
1/16	0.0625	1.588	9/16	0.5625	14.288
5/64	0.0781	1.984	37/64	0.5781	14.684
3/32	0.0938	2.383	19/32	0.5938	15.083
7/64	0.1094	2.779	39/64	0.6094	15.479
1/8	0.1250	3.175	5/8	0.625	15.875
9/64	0.1406	3.571	41/64	0.6406	16.271
5/32	0.1563	3.970	21/32	0.6562	16.667
11/64	0.1719	4.366	43/64	0.6719	17.066
3/16	0.1875	4.763	11/16	0.6875	17.463
13/64	0.2031	5.159	45/64	0.7031	17.859
7/32	0.2188	5.558	23/32	0.7188	18.258
15/64	0.2344	5.954	47/64	0.7344	18.654
1/4	0.2500	6.350	3/4	0.7500	19.050
17/64	0.2656	6.746	49/64	0.7656	19.446
9/32	0.2813	7.145	25/32	0.7813	19.845
19/64	0.2969	7.541	51/64	0.7969	20.241
5/16	0.3125	7.938	13/16	0.8125	20.638
21/64	0.3281	8.334	53/64	0.8281	21.034
11/32	0.3438	8.733	27/32	0.8438	21.433
23/64	0.3594	9.129	55/64	0.8594	21.829
3/8	0.3750	9.525	7/8	0.8750	22.225
25/64	0.3906	9.921	57/64	0.8906	22.621
13/32	0.4063	10.320	29/32	0.9063	23.020
27/64	0.4219	10.716	59/64	0.9219	23.416
7/16	0.4375	11.113	15/16	0.9375	23.813
29/64	0.4531	11.509	61/64	0.9531	24.209
15/32	0.4688	11.908	31/32	0.9688	24.608
31/64	0.4844	12.304	63/64	0.9844	25.004
1/2	0.5000	12.700	1	1.0000	25.4000